

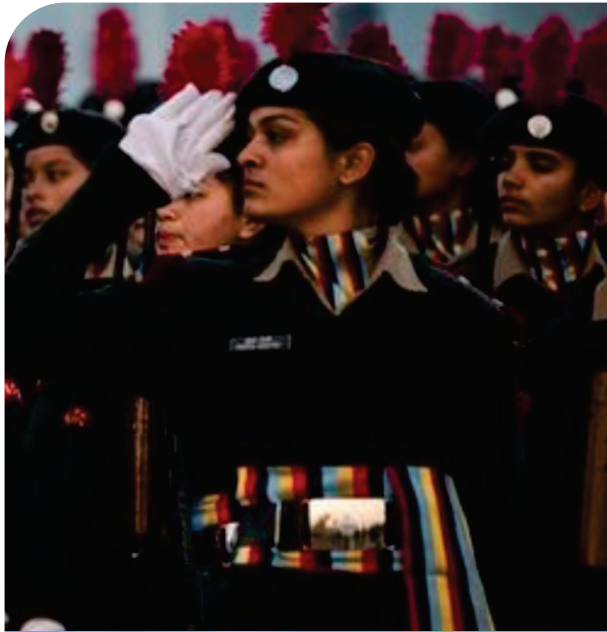

# COMMON SUBJECT TECHNICAL SKILLS



EDITION : 2025

**SD/SW CADETS' HAND BOOK  
NATIONAL CADET CORPS**

National Cadet Corps

**This book or part there of may not be reproduced by  
any person or agency in any manner.**

**Published By:** The Director General, National Cadets Corps  
Delhi-110030



सत्यमेव जयते

# CONSTITUTION OF INDIA

## PREAMBLE

**WE, THE PEOPLE OF INDIA, HAVING**  
solemnly resolved to constitute India into  
a sovereign socialist secular democratic republic  
and to secure to all its citizens :

**JUSTICE,**  
Social, Economic And Political; **LIBERTY**  
of thought, expression, belief, faith and worship;

**EQUALITY**  
of status and of opportunity; and to promote among them all

**FRATERNITY**  
assuring the dignity of the individual and  
the [unity and integrity of the nation];

**IN OUR CONSTITUENT ASSEMBLY**  
this twenty-sixth day of november, 1949, do  
**HEREBY ADOPT, ENACT AND GIVE TO**  
**OURSELVES THIS CONSTITUTION.**



## **NATIONAL ANTHEM**

Jana-Gana-Mana-Adhinayak Jaya He

Bharat-bhagya-vidhata

Punjab-Sindhu-Gujrat-Maratha

Dravid-Utkal-Banga

Vindhya-Himachal-Yamuna-Ganga-

uchchala-jaladhi-taranga

Tava Subha name jage,

tava subha asisa mage, gahe tava jaya-gatha.

Jana-gana-mangala-dayaka

jaya he Bharata-bhagya-vidhata

Jaya he, Jaya he, Jaya he, jaya jaya jaya jaya he.

## **FOREWORD**

It gives me immense pleasure and pride to present the Revised NCC Précis of Common and Special Subjects, 2025 Edition, marking the culmination of a protracted effort mounted for the purpose for more than two years. This achievement has only been made possible through the collective and whole-hearted effort of all stakeholders, comprising the Directorates, the Board of Officers for revision and for printing, & my staff. Your contribution in bringing the project to fruition merits highest appreciation.



The revision was aimed at structuring and updating the syllabus to reflect contemporary thought & realities, as also equip cadets with skills to apply their NCC training in real-life situations. The challenge was to simultaneously keep the language simple for easy comprehension, avoiding too much jargon or pedantry. Endeavour was also to make the presentation interesting and the layout reader-friendly, enabling cadets to engage with each topic meaningfully even through self-study. I extend my sincere appreciation to the entire team for successfully achieving these objectives in their entirety.

This endeavour also aligns the NCC syllabus with tenets of *Vikasit Bharat* for the youth, familiarising NCC cadets with history, geo-strategy, and contemporary technological advances, while remaining rooted in our cultural heritage and ethos. I am sanguine that this vision will be carried forward by present and future generations of cadets, ensuring strong foundations for a robust nation, enabled and ready to achieve greater heights and our rightful place on the global stage.

**GOD bless and JAI HIND**

Director General,  
National Cadet Corps



**MASTER INDEX : NCC TECHNICAL SKILLS (SD/SW)**

SER NO	CODE	SUBJECT	PERIODS			TYPE	PAGE
			1 <sup>st</sup> Yr	2 <sup>nd</sup> Yr	3 <sup>rd</sup> Yr		
<b><u>(CODE - FD) FOOT DRILL (34 PERIODS)</u></b>							
1.	FD-1	General Drill Instructions and Words of Command	2	1	-	T/P	01
2.	FD-2	Savdhan, Vishram, Aaram se aur Mudna	2	2	-	T/P	08
3.	FD-3	Kadwar Sizing, Teen Line Banana, Khuli aur Nikat Line	2	1	-	T/P	15
4.	FD-4	Khade Khade Salute Karna	1	1	-	T/P	22
5.	FD-5	Parade Par, Visarjan and Line Tod, Tej Chal se Tham aur Dhire Chal se Tham	4	3	-	T/P	27
6.	FD-6	Tej chal se Mudna	2	2	-	T/P	36
7.	FD-7	Tej Chal se Salute Karna	2	3	-	T/P	43
8.	FD-8	Tej Kadam Tal se Kdam Badalna	2	-	-	T/P	50
9.	FD-9	Teen 'O' Teen se Ek File aur Ek file se Teen 'O' Teen Banana aur DST Procedure	2	-	-	T/P	54
10.	FD-10	Individual Words of Command	-	2	-	T/P	60
<b><u>(CODE - AD) ARMS DRILL AND CEREMONIAL DRILL (24 PERIODS)</u></b>							
11.	AD-1	Savdhan, Vishram and Aram se with Rifle	1	-	-	P	67
12.	AD-2	Parade Par and Saj Drill with Rifle	1	-	-	P	74
13.	AD-3	Visarjan and Line Tod with Rifle	1	-	-	P	80
14.	AD-4	Bhumi Shastra and Uthao Shastra	1	-	-	P	85
15.	AD-5	Bagal Shastra and Baju Shastra	2	-	-	P	91
16.	AD-6	Salami Shastra, Baju Shastra and Ceremonial Drill	-	8	7	P	97
17.	AD-7	Squad Drill and DST Procedure with Rifle	-	-	3	P	119



SER NO	CODE	SUBJECT	PERIODS			TYPE	PAGE	
			1 <sup>st</sup> Yr	2 <sup>nd</sup> Yr	3 <sup>rd</sup> Yr			
<b><u>(CODE - WT) WEAPON TRAINING (20 PERIODS)</u></b>								
18.	WT-1	Introduction of Point 22 Rifle	1	-	-	P	127	
19.	WT-2	Handling of Point 22 Rifle	2	1	-	P	135	
20.	WT-3	Firing Operation of Rifle	-	1	-	T/P	149	
21.	WT-4	Theory of Grouping and Shot Group Analysis	1	2	-	T	160	
22.	WT-5	Range Procedure and Security of Range	1	1	1	P	169	
23.	WT-6	Short Range Firing	-	3	6	P	181	
<b><u>(CODE - OT) OBSTACLE TRAINING (7 PERIODS)</u></b>								
24.	OT-1	Introduction	1 x Pd Theory	2 x Pd (Familiarisation and OT Practice on ground) in both 2 <sup>nd</sup> year and 3rd year	T/P	186		
25.		Obstacle Course and Negotiation						
26.		Dress						
27.		Obstacles for Senior Wing Cadets	2 x Pd Practical				194	
28.		Practice in Negotiating the Obstacle Course						
29.		Safety Measures for Successful and Safe Completion of the Obstacle Course	195					
30.		Benefits of Obstacle Course Training						
31.		Demonstration						
32.		Schematic Layout of Standard Obstacle Course	197					
<b><u>(CODE - D) DRONES (08 PERIODS)</u></b>								
33.	D-1	Evolution and Types of Drones	1		-	T		203
34.	D-2	Basic Principles of Flight	-	2	-	T		217
35.	D-3	DGCA Rules on Drones	-	2	-	T	230	
36.	D-4	Application of Drones	-	-	1	T	242	
37.	D-5	Drone Operations	-	-	2	T	259	
	<b>Total Periods</b>		<b>15</b>	<b>22</b>	<b>22</b>			



## SUMMARY

SER NO	SUBJECT	1 <sup>ST</sup> YEAR		2 <sup>ND</sup> YEAR		3 <sup>RD</sup> YEAR		TOTAL
		Theory	Practical	Theory	Practical	Theory	Practical	
1.	ARMS DRILL	-	6 x Pds PI Staff	-	8 x Pds PI Staff	-	10 x Pds PI Staff	24
2.	WT	1 x Pds PI Staff	4 X Pds PI staff	3 x Pds PI Staff	5 x Pds PI Staff	-	7 x Pds PI Staff	20
3.	OT	1 x Pds PI Staff	2 x Pds PI Staff	-	2 x Pds PI Staff	-	2 x Pds PI Staff	07
4.	DRONES	1 x Pd Officers/ Trained PI/ AMI/ CGI	-	4 x Pds Officers/ Trained PI/ AMI/ CGI	-	3 x Pds Officers/ Trained PI/ AMI/ CGI	-	08

# **FOOT DRILL**

**1**



### **CHAPTER WISE INDEX : FD (SD/SW)**

<b>Ser No</b>	<b>Content</b>	<b>Page No</b>
1.	Chapter I : General Drill Instructions and Words of Command	01
2.	Chapter II : Savdhan, Vishram, Aaram se aur Mudna	08
3.	Chapter III : Kadwar Sizing, Teen Line Banana, Khuli aur Nikat Line	15
4.	Chapter IV : Khade Khade Salute Karna	22
5.	Chapter V : Parade Par, Visarjan and Line Tod, Tej Chal se Tham aur Dhire Chal se Tham	27
6.	Chapter VI : Tej chal se Mudna	36
7.	Chapter VII : Tej Chal se Salute Karna	43
8.	Chapter VIII : Tej Kadam Tal se Kdam Badalna	50
9.	Chapter IX : Teen 'O' Teen se Ek File aur Ek file se Teen 'O' Teen Banana aur DST Procedure	54
10.	Chapter X : Individual Words of Command	60



## FOOT DRILL (SD/SW)

### CHAPTER FD I : GENERAL DRILL INSTRUCTIONS AND WORDS OF COMMAND

*“Rank may get you Customs & Courtesies but Character will get you Respect”*



### TEACHING INSTRUCTIONS

**Total Periods** : Three (03).

**Type** : Theory & Practical.

**Year** : Ist Year - 02 Periods & IInd Year - 01 Period.

**Conducting Officer** : Permanent Instructor.

**Training Aids** : Black Board, Chart & Training Video.

<u>Time Plan</u>	<u>I<sup>st</sup> Year</u>	<u>II<sup>nd</sup> Year</u>
• Introduction/ Recapitulation (Theory) :	10 Min	05 Min
• General Instructions of Drill (Practical) :	30 Min	15 Min
• Words of Command (Practical) :	30 Min	15 Min
• Revision/Consolidation (Theory/Practical) :	10 Min	05 Min



## INTRODUCTION

1. Foot drill is a part of the training schedule of the Armed Forces worldwide. “Foot Drill” or “Drill” stems from time since antiquity when soldiers would march into battle, be expected to gather in a formation and react to words of command from their commanders once the battle commenced. In the history of Army, the training of drill started with the objective of uniting the troops and making them march in a uniform manner. Drill is an effective means through which discipline, turnout and team spirit are inculcated in the troops. Drill thus has played a key role in maintaining the foundation of discipline even in the battlefield.



### PREVIEW

This lesson will be conducted in two parts:-

- (a) Part I : General Drill Instructions.
- (b) Part II : Words of Command.

### LEARNING OBJECTIVES

- Basic understanding of drill.
- Definition of drill, types of drill.
- Purpose and principle of drill.
- Bad habits of drill.
- Words of command.



## PART I : GENERAL INSTRUCTIONS FOR DRILL

2. **Definition of Drill.** The process of performing a procedure in a sequential and proper manner is called drill.

3. **Types of Drill.** There are two types of drills:-

(a) **Open Drill.** It is done in the field.

(b) **Close Drill.** Close drill is done in **peace** on parade ground.



4. **Purpose of Drill.** Drill has the following purposes:-

(a) Drill is the foundation of **discipline**.

(b) Drill inculcates the habit of **working together** and following **orders**.

(c) Drill teaches **command and control** to all Cadets and individuals.

(d) Drill teaches how to **wear uniform** and **walk**.

(e) By observing the drill, one can judge the **discipline** and **morale** of a cadet.

5. **Principles of Drill.** There are three principles of drill:-

(a) Smartness.

(b) Steadiness.

(c) Co-ordination.

6. **Principles of foot drill.** Shoot the feet forward.

7. **Undesirable Habits in Drill.** Undesirable habits in drill are as follows:-

(a) Rolling of the eyes.

(b) Hopping and jumping.

(c) Dragging the feet.

(d) Clicking the heels.

(e) Moving the toes in boots.



## **PART II : WORDS OF COMMAND**

8. A correct word of command depends on the **tone** and **pitch** of the voice. The correct word of command is given in a **clear** and **loud** voice so that it is acted upon immediately. The following points are important for giving a good word of command:-

(a) **Loudness (Swar)**. The loudness of the Word of Command depends on how many people are being given the word of command and how far apart they are. To give the Word of Command, the commander stands in front of his squad, facing them. The Word of Command is always given in **SAVDHAN** position.

(b) **Clarity (Spasht)**. A **clear** word of command should be given with proper coordination of tongue, lips and teeth. A poor word of command will neither generate the enthusiasm, nor the zeal, spirit or excitement in the squad.

(c) **Pitch**. Correct **pitch** is essential for correct word of command.

(d) **Timing**. Correct **timing** of word of command is very important for its immediate implementation. A word of command has two parts '**Cautionary** and **Executive**'. There should be a difference of four quick steps between Cautionary and Executive word of command. In quick march (**tej chal**) '**Cautionary**' word of command starts on the **left foot**.



9. **Words of Command**. The following words of command are given in the drill (Demonstrate sample with statements):-

- (a) **SAVDHAN** aur **VISHRAM**
- (b) **DAHINE MUD** ya **BAYEN MUD**
- (c) **PICHE MUD**
- (d) **DAHINE DEKH** ya **BAYEN DEKH**
- (e) **TEJ CHAL** ya **DHIRE CHAL** aur **THAM**
- (f) **KHULI LINE CHAL** ya **NIKAT LINE CHAL**
- (g) **LINE BAN, SAJ JA** ya **VISARJAN**
- (h) **DAHINE SALUTE, BAYEN SALUTE** ya **SAMNE SALUTE**



## CONCLUSION

10. Drill is an important part of organized NCC and Army training. It instills a strong sense of discipline amongst cadets, which is essential for succeeding in life. Drill also helps in developing correct military bearing and conduct. Right grooming, with confidence instilled will not only make the cadets an ambitious leader but would also impose the responsibility of efficiently carrying the Team. The appearance and turn out arises self- confidence which in a way develops the quality of immediate and implicit obedience to orders and teamwork.

## SUMMARY

- The process of performing a procedure in a systematic and proper manner is called drill.
- There are two types of drills: -
  - **Open Drill.** It is done in open on field.
  - **Close Drill.** It is done on the parade ground, while in peace.
- There are three principles of drill: -
  - Smartness.
  - Steadiness.
  - Coordination.
- **Principles of foot drill.** Shoot the feet forward.
- Drill has the following objectives:-
  - Drill is the foundation of **discipline** and inculcates the habit of **working together** by following orders.
  - Drill teaches **command and control** to Cadets and Officers alike.
  - Drill teaches how to **wear uniform smartly** and **walk with confidence**. By observing drill, one can judge the **discipline** and **morale** of a cadet.

**ASSESSMENT EXERCISE****Multiple Choice Questions**

Q1. How many types of drill are there?

- (a) Two (b) Four  
(c) Five (d) Eight

Q2. How many types of Words of Command are there?

- (a) Three (b) Four  
(c) Two (d) Seven

Q3. How many types of foot drill are there?

- (a) Two (b) Five  
(c) Three (d) Seven

Q4. Correct pause is essential for?

- (a) Foot drill (b) Arms drill  
(c) Ceremonial drill (d) All the above

Q5. A properly delivered 'Command' is \_\_\_\_\_ and Distinct enough to be clearly understood by every person.

- (a) Slow (b) Heavy  
(c) Long (d) Loud

Q6. The word of command \_\_\_\_\_ is given for final dispersal at the end of the parade.

- (a) Visarjan (b) Aaram Se  
(c) Kadam Tal (d) Line Tod

Q7. The Drill which is done during peace time and in parade ground is called\_\_\_\_\_.

- (a) Close Drill (b) Ceremonial Drill  
(c) Foot Drill (d) Open Drill



- Q8. During Drill, you should not do the following:-
- (a) Roll your eyes                      (b) Lift your knees  
(c) Dig your heels                      (d) Swing your arms
- Q9. During Drill, you should not do the following:-
- (a) Click your heels                      (b) Drag your feet  
(c) Both of these                      (d) None of these
- Q10. Word of Command is always given in \_\_\_\_\_ position.
- (a) Saavdhan                              (b) Vishram  
(c) Aram Se                              (d) Picche Se
- Q11. Clarity of Word of Command can be achieved by good coordination of the following:-
- (a) Tongue, Teeth and Lips              (b) Teeth and Lips  
(c) Tongue and Lips                      (d) None of these
- Q12. Following are the parts of Word of Command:-
- (a) Loud and Clear                      (b) Cautionary and Executive  
(c) Pitch and clarity                      (d) Loudness and Pitch

### **Short Answer Questions.**

- Q1. Write definition of drill?
- Q2. How many principles are there in drill?
- Q3. What is the purpose of drill?
- Q4. What are the undesirable habits in drill?
- Q5. Write names of training aids for drill?

### **Long Answer Questions**

- Q1. Write the objective of drill?
- Q2. What are the bad habits in drill?
- Q3. Write the method of teaching drill?
- Q4. Write the method of giving words of command in drill?
- Q5. How many types of words of command are given in drill? Write in detail.
- Q6. What are the words of command and why is it needed?



## FOOT DRILL (SD/SW)

### CHAPTER FD II : SAVDHAN, VISHRAM, AARAM SE AUR MUDNA

“The Harder you Train, the Harder you are to Beat”



### TEACHING INSTRUCTIONS

<b>Total Periods</b>	: Four (04).
<b>Type</b>	: Lecture and Practice.
<b>Year</b>	: Ist Year - 02 Periods & IInd Year - 02 Periods.
<b>Conducting Officer</b>	: Permanent Instructor.
<b><u>Training Aids</u></b>	: Chart, Black Board & Training Video.

<b><u>Time Plan</u></b>		<b><u>Ist Year</u></b>	<b><u>IInd Year</u></b>
➤ Introduction/Recapitulation (Theory)	:	20 Min	15 Min
➤ Savdhan, Vishram, Aaram Se (Practical)	:	25 Min	30 Min
➤ Khade Khade Mudna (Practical)	:	25 Min	30 Min
➤ Revision/Consolidation (Practical)	:	10 Min	05 Min

## INTRODUCTION

1. Whenever any drill action is to be performed, it always starts from the **Savdhan** position. Apart from this, if you have to talk to your senior, the conversation is done from **Savdhan** position only. The body posture has to be upright, and one should not be leaning on anything or standing on one leg. When you finish talking to your senior, then **Vishram** is done or when the drill action is over, you do **Vishram aur Aram Se**.



### PREVIEW

This lesson will be conducted in two parts:-

1. Part I : Savdhan, Vishram aur Aram Se.
2. Part II : Khade Khade Mudna.

### LEARNING OBJECTIVES

1. Basic understanding of Savdhan, Vishram, Aram Se and Mudna.
2. Bayan aur ginti ke saath namuna.

## PART I : SAVDHAN, VISHRAM AUR AARAM SE

### 2. Savdhan.

(a) Whenever any action has to be done in the drill, it always starts from the **Savdhan** position. Apart from this, if you have to talk to your seniors then the conversation is done in **Savdhan** position only.



(b) **Bayan se Namuna.** When you get the word of command **Savdhan** raise your left foot to 6 inches and join the heel of your right foot with the heel of your left foot. When your left foot touches the ground, shout '**Ek**'. Things to observe in this position are:-

- (i) Both heels are joined and the angle of toes is 30 degrees apart.
- (ii) Both knees should be tightly held and steadfast.
- (iii) Both arms should be joined along the stitching of the trouser on right and left side, and the fists should be closed naturally.
- (iv) Trousers should be pulled up till navel, chest raised, shoulders pulled back, neck joined to the collar, chin up and eyes should be focused in front.



### 3. **Vishram aur Aaram Se.**

(a) When we finish the discussion with the senior or after the drill activity is over, we come to **Vishram aur Aaram Se.**

(b) **Bayan se Namuna.** When you get the word of command **Vishram** from the **Savdhan** position, raise your left foot 6 inches, move 12 inches away and keep it on the ground and at the same time, take both the arms back, hold your left hand below and right hand above and shout '**Ek**'. Things to look at in this position are:-

- (i) 12 inches distance between the heels.
- (ii) Both knees are tightly held.
- (iii) Both hands are joined behind, left hand below and right hand and fingers pointing down.
- (iv) Distribution of weight is even on both the feet.
- (v) On the word of command **Aaram Se**, relax the upper part of the body above the waist but the feet will not move.



## **PART II : KHADE KHADE MUDNA**

### 4. **Dahine Mudna.**

(a) When we are standing at a place and have to change our direction and formation to 90 degrees to the right, then **Dahine Mud** is done.



(b) **Demonstration by Statement and Count (Ginti aur Bayan se Namuna).**

(i) When you get the word of command from **Savdhan** position, count '**Ek**' and on this word of command turn your right foot and the toe of your left foot quickly to 90 degrees towards the right and shout '**Ek**'. Things to see in this position are that the right foot is completely on the ground and the weight of the body is on the right foot, the toes of the left foot are on the ground and the left heel is raised and both legs are turned briskly.

(ii) When you get the word of command '**Do**' on this word of command raise your left foot 6 inches up and place it close to your right foot and shout '**Do**'. Things to observe in this position - The direction should be changed to 90 degrees on the right side.

5. **Bayan Mudna.**

(a) When we are standing at one place and need to change our direction and formation by 90 degrees to the left then the action of '**Bayan Mud**' is done.

(b) **Demonstration by Statement and Count (Ginti aur Bayan se Namuna).**

(i) When you get the word of command from the '**Savdhan**' position count '**Ek**' and on this word of command with the help of the left foot and the toes of the left foot, turn left at 90 degrees and shout '**Ek**'. Things to observe in this position – the weight of the body should be on the left foot and the right foot should be on the ground. The toe of the right foot should be on the ground and the heel should be raised, both legs should be tightly kept.

(ii) When you get the word of command '**Do**', raise your right foot 6 inches up and place with your left foot and shout '**Do**'. Things to look out for in this position - the direction should be changed to 90 degrees on the left side.

6. **Pichhe Mudna.**

(a) When we stand at a place and change the direction 180 degrees backwards while keeping our formation, then **Pichhe Mud** is done.

(b) **Demonstration by Statement and Count (Ginti aur Bayan se Namuna).**

(i) When you get the word of command from the **Savdhan** position **Ginti se Mudna Ek**, then on this word of command turn quickly to 180 degrees backwards on the right foot and the toes of the left feet on the ground and heel raised and shout '**Ek**'. Things to see in this position – the right foot is completely on the ground; the weight of the body is on the right foot and the toes of the left foot are raised from the ground. The muscles of both legs are tightened and the thighs are locked.



(ii) When you get the word of command '**Do**', raise your left foot 6 inches above your right foot and put with your right foot and shout '**Do**'. The thing to watch out for in this position is that the direction should be changed to 180 degrees and the rest of the positions should be same as '**Savdhan**'.

7. **Aadha Dahine Aur Bayen Mudna.**

(a) When the standing squad has to practice salute or if right/left squad has to be formed or change of direction action has to be done then '**Aadha Dahine ya Bayen Mud**' is done.

(b) **Demonstration by Statement and Count (Ginti aur Bayan se Namuna).**

(i) The action is same as '**Dahine/Bayen Mud**', the only difference being that you have to turn half left/right by 45 degrees only.

## CONCLUSION

8. **Savdhan, Vishram, Aaram Se, and Mudna** are basic movements and word of command of drill. Learning of these movements is a prerequisite for Arms and Ceremonial Drill. Instructor must demonstrate these movement by statement and count. The cadets must practice and observe timings carefully while carrying out any movement of drill.

### DID YOU KNOW?

- '**Savdhan**' command is given when a drill has to commence or when the cadet is talking to or being addressed by his senior officer.
- The command '**Vishram**' is given when the drill has got over or when the address of the senior officer is over.
- Cadets are given '**Aaram Se**' to rest without movement.

### SUMMARY

- When any drill action has to be done, it always starts from the '**Savdhan**' position. Apart from this, if you have to talk to your senior, then the conversation is done in '**Savdhan**' position only.
- In assuming the position of '**Savdhan**', heels are brought together with extreme sharpness by lifting the left foot six inches from the ground and placing it flat and very firm besides the right, avoiding stamping of foot.
- When we finish talking with the senior, then '**Vishram**' is done or after the drill is over, we come to '**Vishram**'.
- When we are standing at a place and have to change our alignment and formation at 90 degrees to the right, then '**Dahine Mud**' is done.
- When we are standing at a place and have to change our alignment and formation at 90 degrees to the left then '**Bayen Mud**' is done.
- When we are standing at a place and have to change the direction while maintaining our formation at 180 degrees towards back then '**Piche Mud**' is done.



## ASSESSMENT EXERCISE

### Multiple Choice Questions

- Q 1. How many inches do you raise your left foot in the *Savdhan* position?
- (a) 4 inch (b) 6 inch  
(c) 2 inch (d) 8 inch
- Q 2. What is the angle of the toe in the *Savdhan* position?
- (a) 40 degree (b) 30 degree  
(c) 20 degree (d) 50 degree
- Q 3. In *Vishram* position what is the distance between the heels in inches?
- (a) 10 (b) 12  
(c) 16 (d) 18
- Q4. In *Vishram* position what angle of degrees is formed?
- (a) 50 (b) 30  
(c) 20 (d) 10
- Q5. In '*Vishram*', the distance between both feet, at the heel, in inches is\_\_\_\_\_.
- (a) 10 (b) 16  
(c) 12 (d) 18
- Q6. In *Savdhan* position, the hand should be in line with \_\_\_\_\_.
- (a) Ground (b) Waist  
(c) Shoulder (d) Stitching of the pants
- Q7. In *Vishram* position, the Right palm should be \_\_\_\_\_ the left palm.
- (a) Behind (b) Below  
(c) In front of (d) To the right of
- Q8. In *Vishram* position, the Right thumb should be \_\_\_\_\_ the left thumb.
- (a) Behind (b) Below  
(c) In front of (d) To the right of
- Q9. In *Vishram* position, the weight of the body should be \_\_\_\_\_.
- (a) On Right Leg (b) On both the legs  
(c) Slightly in front (d) Slightly behind
- Q10. In *Savdhan* position, the shoulder is to be\_\_\_\_\_ to the ground.
- (a) Parallel (b) Perpendicular  
(c) At 45 degrees (d) At 30 degrees



Q11. On the word of command, '*Ginti se Bayen Mud Ek*', you must turn, 90 degrees to Left, with the weight of the body on the \_\_\_\_\_ leg.

- (a) Right (b) Both  
(c) Left (d) All of these

Q12. On the word of command, '*Ginti se Dahine Mud Ek*', you must turn, 90 degrees to Right, with the weight of the body on the \_\_\_\_\_ leg.

- (a) Right (b) Both  
(c) Left (d) All of these

Q13. '*Piche Mud*' is actually equal to \_\_\_\_\_.

- (a) Two consecutive '*Dahine Muds*'  
(b) Two consecutive '*Bayen Muds*'  
(c) Both of these  
(d) None of the above

### **Short Answer Questions**

- Q1. Where does any movement of the drill start from?
- Q2. Why is *Savdhan aur Vishram* required?
- Q3. Why is it necessary to turn standing and at what degree?
- Q4. At what degree do we turn left and right?
- Q5. Why is it necessary to turn backwards?
- Q6. Write the word of command for the number of samples turning backwards?
- Q7. Write the word of command for the number of samples turning right and left?

### **Long Answer Questions**

- Q1. Write in detail the things to be observed in *Savdhan* and *Vishram* position.
- Q2. Write about right facing and left facing position.
- Q3. Write the things to be observed in back facing position.
- Q4. Why is there a need of half right and left facing?
- Q5. Write the things to be observed in half right and left facing position.



## FOOT DRILL (SD/SW)

### CHAPTER FD III : KADWAR SIZING, TEEN LINE BANANA, KHULI AUR NIKAT LINE

**“Never Stop Believing in your Abilities”**



### TEACHING INSTRUCTIONS

- Periods** : Three (03).
- Type** : Lecture and Practice.
- Year** : Ist Year - 02 Periods & II<sup>nd</sup> Year - 01 Period.
- Conducting Officer** : Permanent Instructor.
- Training Aids** : Chart, Black Board & Training Video.

<u>Time Plan</u>	<u>Ist Year</u>	<u>IInd Year</u>
➤ Introduction/Recapitulation (Theory)	: 10 Min	05 Min
➤ Kadwar Sizing (Practice)	: 20 Min	10 Min
➤ Teen Line Banana (Practice)	: 20 Min	10 Min
➤ Khuli Line aur Nikat Line mein Chal (Practical)	: 20 Min	10 Min
➤ Revision/Consolidation (Theory/Practical)	: 10 Min	05 Min



## INTRODUCTION

1. A well sized squad, gives a good general view and impression to audience and provides the best chance to do the drill together. Sizing is done to have tallest on the right and shortest the left in a single file. On command for sizing, the whole squad turns right, counts and then sort themselves out by size, remaining at attention facing the instructor in one single line. The **Kadwar** parade and squad looks good when seen from a distance.



### PREVIEW

This lesson will be conducted in three parts:-

1. Part I : Kadwar Sizing
2. Part II : Teen line Banana
3. Part III : Khuli Line aur Nikat Line mein Chal

### LEARNING OBJECTIVES

1. Need of kadwar sizing
2. How to make teen line
3. Khuli line aur nikat line chal



## PART I : KADWAR SIZING

### 2. Kadwar Sizing.

(a) **Need. Kadwar Sizing** is always required in drill, especially for ceremonial drill. In this, the entire squad is made to stand in a line so that the taller ones stand to the right and the smaller ones stand to the left according to height, to give an orderly look to the Drill squad.

#### (b) Demonstration by Statement and Count (Bayan aur Ginti Se Namuna).

(i) In any formation, the standing squad gets the word of command to do the **Kadwar Sizing**. On receiving the word of command “**Squad - Lamba Dahine - Chota Bayen - Ek Line Mein Kadwar Khade Ho**”, then the complete squad does **Line Tod** and the tallest cadet stands to the right while the rest of the cadets stand to his left according to decreasing height.

(ii) On receiving the word of command ‘**Squad Ginti Kar**’, then start counting 1, 2, 3... from the tallest cadet on the right. On further receiving the word of command “**Visham Ek Kadam Aage aur Sam Ek Kadam Piche**” the odd numbers take one step forward and even numbers take one step backwards.

(iii) On further receiving the word of command ‘**Number Ek Khada Rahe, Visham Dahine aur Sam Bayen, Dahine Bayen Mud**’ the squad does **Tej Chal** and one by one stand in threes behind the Number 1 Cadet. Number 1 cadet will be the first cadet of the first Line, Number 3 cadet will be the first cadet of the Middle Line and Number 5 cadet will be first cadet of the Last Line. In this manner the squad will be dressed with the taller cadets on the Left and Right and the shorter cadets in the center of the squad.

## PART II : TEEN LINE BANANA

### 3. Teen Line Banana.

(a) **Need.** When the number of personnels are more than nine, action is taken to form three files (lines).

#### (b) Demonstration by Statement and Count (Bayan aur Ginti Se Namuna).

(i) When the word of command is received - No 1 **Line Ban** then as per procedure Number 2 cadet will stand behind Number 1 cadet and similarly Number 3 cadet will stand behind Number 2 cadet one step behind, do **Tham** and say ‘Up’. They will then come to **Vishram**. Then on receiving word of command Number 4 **Line Ban**, Number 4 cadet does **Savdhan**, marches and stands left of Number 1 cadet at a distance of one arm length and says ‘Up’. Number 5 cadet does similar action and stands to the left of Number 2 cadet while covering Number 4 cadet. In a similar manner the rest of cadets will continue the procedure.



(ii) If the squad has a strength of 11, 14, 17, 20, then always from the left, Number 2 file and middle line will have an empty space. If squad is of the strength of 10, 13, 16, 19, then from the left Number 2 file and Middle and Rear Line will have an empty space. If the squad has to be marched towards left or right then word of command will be '**Squad Teen O Teen Mein Dahine Baye Mud**'.

### **PART III : KHULI LINE AUR NIKAT LINE CHAL**

#### **4. Khuli Line Chal.**

(a) **Need.** When the squad has to conduct a weapon exercise or an important dignitary has to inspect during a Ceremonial Drill, then '**Khuli Line Chal**' is done.

(b) **Demonstration by Statement and Count (Bayan aur Ginti Se Namuna).**

(i) When from *Savdhan* position word of command is received '**Ginti Se Chalna Khuli Line Chal - ek**', then raise your left leg by 6 inches and put it ahead by 30 inches flat on the ground with the right feet toe firmly on the ground and heel lifted. In this position both the legs will be straight and tight and rest of the position will be like '*Savdhan*'.

(ii) When the word of command is received '**Squad Do**' then raise your right foot by 6 inches and place it forward by 15 inches and align it with the heel of left foot and come to '*Savdhan*' position. Keep in mind that you should have covered 45 inches from previous position and should be in '*Savdhan*' position.



#### **5. Nikat Line Chal.**

(a) **Need.** Once the inspection is over, then '**Nikat Line**' is done before marching.

(b) **Demonstration by Statement and Count (Bayan aur Ginti Se Namuna).**

(i) When from '*Savdhan*' Position you get a word of command '**Ginti Se Chalna Nikat Line Chal - Ek**', to this command lift your left leg by 6 inches and place it 30 inches behind your right leg with your weight on your left leg and count **Ek**. In this position, the whole left leg should be flat on the ground 30 inches behind the right foot with the right heel on the ground and toe lifted. The rest of the position is similar to '*Savdhan*'.





(ii) When word of command is given '**Squad Do**' then lift right leg 6 inches above the ground and stamp it 15 inches behind, aligned to the left foot. In this position, you will move 45 inches behind your previous position. The rest of the position is like '**Savdhan**'.

### Did You Know?

- **Kadwar Sizing** is always required in drill, especially for ceremonial drill.
- When the number of personnels are more than nine, action is taken to form three files (lines).
- When the squad has to perform arms drill, or when the squad has to be inspected in a large parade, then '**Khuli Line**' is done.
- During practice '**Khuli Line Chal**' and '**Nikat Line Chal**' is on voice count but on actual parade it is done without loud voice.

### CONCLUSION

6. Sizing of the squad is required for ceremonial drill. The sized squad looks good when viewed from a distance. In this the whole squad is made to stand in a line so that the taller ones stand to the right and the smaller ones stand to his left as per the height. Cadets must be taught these basic Foot Drill movements to prepare them for Squad/Ceremonial Drill.

### SUMMARY

- **Kadwar Sizing** is required in drill, especially for the ceremonial drill. In this the whole squad is made to stand in a line so that the taller ones stand to the right and the smaller ones stand to his left according to size. When the squad is to be inspected by VIPs on large parade or arms drill is to be practiced then '**Khuli Line Chal**' is done.
- When the number of personnels are more than nine, action is taken to form three files (lines).



## ASSESSMENT EXERCISE

### Multiple Choice Questions

Q1. When is *Kadwar Size* required?

- (a) Ceremonial drill (b) Foot drill  
(c) Arms drill (d) Close drill

Q2. How many inches does one raise the left foot while doing *Khuli Line*?

- (a) 6 (b) 8  
(c) 10 (d) 9

Q3. How many inches behind should the left foot be placed in *Nikat Line*?

- (a) 50 (b) 30  
(c) 20 (d) 10

Q4. A line of men standing one behind the other is called \_\_\_\_\_.

- (a) Lane (b) File  
(c) Drill (d) Rank

Q5. During the process of *Kadwar Sizing* of a drill squad, all are made to stand in one line with the tallest standing at the \_\_\_\_\_.

- (a) Left (b) Right  
(c) Centre (d) Back

Q6. During the process of *Kadwar Sizing* of a drill squad, after all are made to stand in one line according to height and call out numbers, \_\_\_\_\_ is/are asked to step forward.

- (a) Even Numbers (b) Every Third Number  
(c) Odd Numbers (d) Whole Numbers

Q7. After completion of *Kadwar Sizing* of a squad, the right most rank of the squad will have the cadets who shouted the following numbers standing in sequence from the first line.

- (a) 1,3 & 5 (b) 1,5 & 7  
(c) 2,4 & 6 (d) Any of the above

Q8. After completion of *Kadwar Sizing* of a squad of 33 cadets, the left most rank of the squad will have the cadets who shouted the following numbers standing in sequence from the first line.

- (a) 6,4 & 2 (b) 29,31 & 33  
(c) 2,4 & 6 (d) 33,31 & 29



- Q9. When the number of cadets is more than \_\_\_\_ a three-line squad is made.
- (a) 12 (b) 8  
(c) 15 (d) 9
- Q10. When the number of cadets in a squad is 11, 14, 17, 20 etc, the second file from the left will have 'NO' cadet in \_\_\_\_\_ line.
- (a) Middle and Last (b) Last  
(c) Middle (d) First and Middle
- Q11. When the number of cadets in a squad is 10, 13, 16, 19 etc., the second file from the left will have 'NO' cadet in \_\_\_\_\_ line.
- (a) Last (b) Middle and Last  
(c) Middle (d) First and Middle
- Q12. In '*Khuli Line Chal*', a cadet in front line will take a final position which is \_\_\_\_\_ inches in front of the original position.
- (a) 30 (b) 90  
(c) 60 (d) 45
- Q13. In '*Nikat Line Chal*', a cadet in middle line will take a final position which is \_\_\_\_\_ in relation from his/her original position.
- (a) 45 inches ahead (b) 45 inches behind  
(c) 30 inches ahead (d) None of these

### **Short Answer Questions**

- Q1. Why *Kadwar Sizing* is necessary?
- Q2. When is three lines formed?
- Q3. When is '*Khuli Line*' and '*Nikat Line*' required?
- Q4. What is the word of command for *Kadwar Sizing*?
- Q5. Write the points to be observed in position of '*Khuli Line*' and '*Nikat Line*'?

### **Long Answer Questions**

- Q1. Write in detail about *Kadwar Sizing*?
- Q2. How are Three Lines made?
- Q3. How is '*Khuli Line*' done?
- Q4. What are the points to be kept in mind while doing '*Khuli Line*' and '*Nikat Line*'?
- Q5. How is '*Nikat Line*' done?



## FOOT DRILL (SD/SW)

### CHAPTER FD IV : KHADE KHADE SALUTE KARNA

“We Salute the Rank not the Man”



### TEACHING INSTRUCTIONS

<b>Total Periods</b>	: Two (02).
<b>Type</b>	: Lecture and Practice.
<b>Year</b>	: Ist Year - 01 Period & IInd Year - 01 Period.
<b>Conducting Officer</b>	: Permanent Instructor.
<b><u>Training Aids</u></b>	: Chart, Black Board & Training Video.

<b><u>Time Plan</u></b>		<b><u>Ist Year</u></b>	<b><u>IInd Year</u></b>
a. Introduction/Recapitulation (Theory)	:	05 Min	05 Min
b. <b><i>Khade Khade Salute Karn</i></b> (Practical)	:	10 Min	10 Min
c. Practice (Practical)	:	20 Min	20 Min
d. Revision/Consolidation (Theory/Practical)	:	05 Min	05 Min



## INTRODUCTION

1. Salute is a formal way of showing respect in uniform. When we are standing at any place and any officer authorised a salute passes in front of us, then to give respect to him, we salute him while standing in front of him. Similarly, right salute and left salute are also given as per the position and direction in which the dignitary is standing.

### PREVIEW

This lesson will be conducted in two parts:-

3. Part I : Khade Khade Salute Karna.
4. (b) Part II : Dahine/Bayen Salute

### LEARNING OBJECTIVES

1. Need of khade khade salute.
2. Demonstration with statement and count (ginti aur bayan ke saath namuna).

## PART I : KHADE KHADE SALUTE KARNA

2. **Need.** When we are standing at any place and any officer who is authorised to a salute passes in front of us, then to give respect to him, the act of saluting is done standing in front of him. Similarly, the act of right salute and left salute are also done.

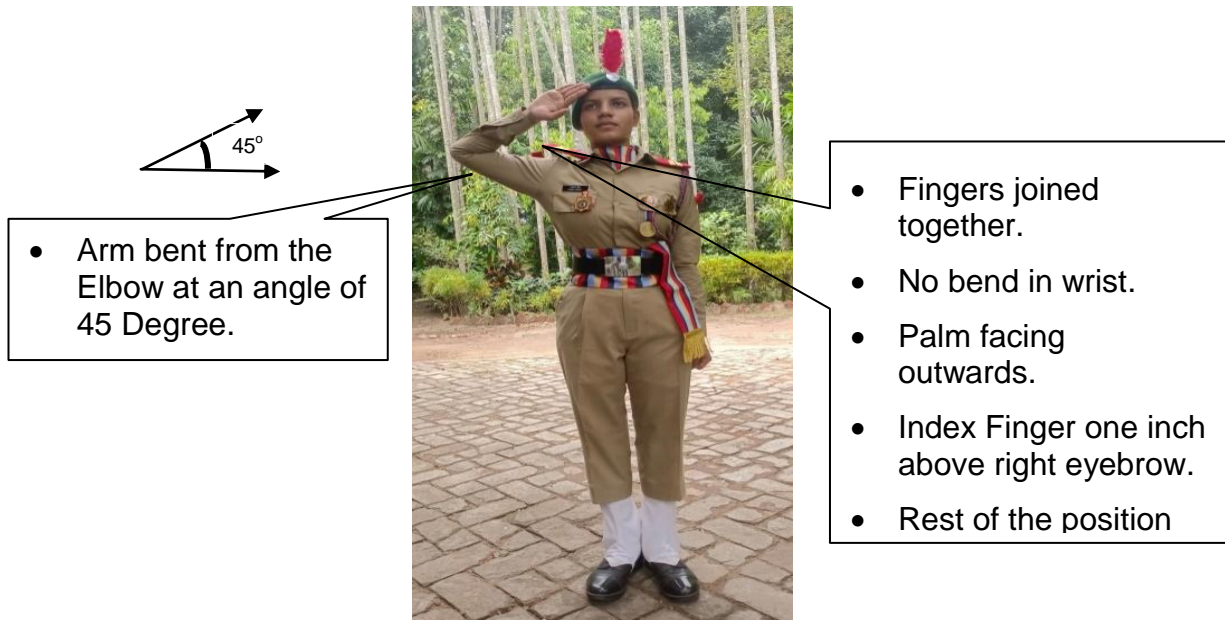

### 3. Demonstration by Statement and Count (*Ginti aur Bayan se Namuna*).

(a) On receiving the word of command “***Ginti se Salute Karna Samne Salute Ek***”, lift the right hand over the right shoulder from the side, bending from the elbow, place the right palm in such a manner that the Index Finger of the right hand is 1 inch above the right eyebrow. In this position all the fingers of your right hand should be together, Index Finger of right hand 1 inch above right eyebrow and arm bent from the elbow at an angle of 45°. The rest of the position is like ***Savdhan***.

(b) On receiving the word of command ***Squad Do***, bring down the right hand from the shortest route to your right side as in ***Savdhan*** position. The rest of the position is like ***Savdhan***.

## PART II : DAHINE/ BAYEN SALUTE

4. ***Dahine/Bayen Salute***. It means Salute to the flank (right and left). ***Dahine ko Salute*** (Salute to the right) is best taught from the position of the salute to the front. Cadet takes his/her position of the salute to the front. He/she turns his/her head, eyes square off to the right, without upsetting the position of the right arm, wrist or hand and shifts the head so that right eye can just look along the palm of the hand. The cadet either looks along his/her own height or into the eyes of the dignitary he/she is saluting. For ***Bayen ko Salute*** (Salute to left), all actions are same except that cadet turns his/her head to the left.

### Did You Know?

- Have you ever thought that the style of saluting of Indian Army, Navy and Air Force is different.
- Indian Army salutes by keeping the palm facing front. Navy salutes by lowering the palm. Air Force salutes with palm at an angle of 45 degree.
- In Indian Army, the palm facing front signifies the person saluting does not have a weapon, is harmless and can be trusted.

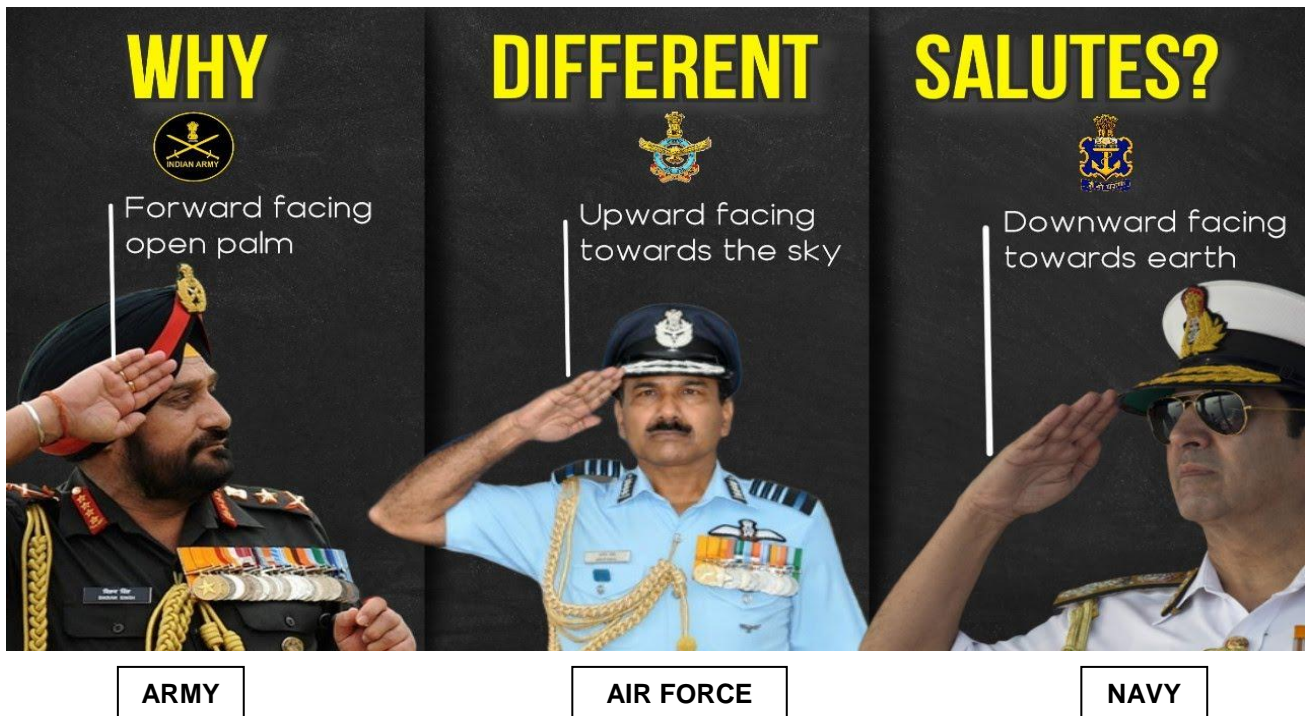

## CONCLUSION

5. Salute is a formal way of showing respect in uniform. While standing, salute can be given to a person or a dignitary in front, right or left, while in **Savdhan**.

## SUMMARY

- When we are standing at any place and any officer who is authorised salute passes in front of us, then to give respect to him, the act of saluting is done standing in front of him. Similarly right salute and left salute are also performed.
- **Khade Khade Salute** is always given in **Savdhan** position.
- Things to look at and ensure in this position - fingers and thumb of the right hand are straight and joined. Index finger is 1 inch from the eyebrow of the right eye and right hand is bent at an angle of 45 Degrees from the elbow.
- In **Dayen/Bayen Salute**, the head is turned to right/left with eyes looking onward the direction of salute. The hand, wrist and palm position remains the same as in salute facing from the front.



## ASSESSMENT EXERCISE

### Multiple Choice Questions

- Q 1. How many types of standing salutation movements are there?  
(a) 5 (b) 4  
(c) 3 (d) 2
- Q 2. What is the angle between the wrist and the elbow when doing a salute?  
(a) 50 (b) 30  
(c) 45 (d) 15
- Q 3. What is the distance of index finger of right hand from the eyes while saluting?  
(a) 2 inch (b) 6 inch  
(c) 5 inch (d) 1 inch
- Q4. In front salute the angle formed at the right elbow is \_\_\_\_\_ degrees.  
(a) 30 (b) 45  
(c) 60 (d) 75

### Short Answer Questions

- Q1. Why is there a need to salute while standing?
- Q2. What is difference in Salute in Indian Army, Navy and Airforce?
- Q3. How many types of standing salutes are there in Foot Drill?
- Q4. What are the words of command for saluting while standing?
- Q5. How many movements are there in standing salute?

### Long Answer Questions

- Q1. Write in detail the general description of *Khade Khade Salute* in front, with count?
- Q2. Write with description about standing *Samne Salute*?
- Q3. Write with description about standing *Dahine Salute*?
- Q4. Write with description about standing *Bayen Salute*?
- Q5. What are the things to look for in a standing salute position?



## FOOT DRILL (SD/SW)

### CHAPTER FD V : PARADE PAR, VISARJAN AUR LINE TOD, TEJ CHAL SE THAM AND DHIRE CHAL SE THAM

**“Drill Requires Sacrifice”**



### TEACHING INSTRUCTIONS

<b>Total Periods</b>	:	Seven (07).
<b>Type</b>	:	Lecture and Practice.
<b>Year</b>	:	Ist Year - 04 Periods & IInd Year - 03 Period.
<b>Conducting Officer</b>	:	Permanent Instructor.
<b><u>Training Aids</u></b>	:	Chart, Black Board & Training Video.

<b><u>Time Plan</u></b>	<b><u>Ist Yr</u></b>	<b><u>IInd Yr</u></b>
• Introduction/Recapitulation (Theory)	: 10 Min	05 Min
• Parade Par (Practical)	: 20 Min	10 Min
• Visarjan (Practical)	: 20 Min	10 Min
• Line Tod (Practical)	: 20 Min	10 Min
• Revision/Consolidation (Theory/Practical)	: 10 Min	05 Min
• Introduction/Recapitulation (Theory)	: 10 Min	10 Min
• <i>Tej Chal aur Tham</i> (Practical)	: 30 Min	30 Min
• <i>Dhire Chal aur Tham</i> (Practical)	: 30 Min	30 Min
• Revision/Consolidation (Theory/Practical)	: 10 Min	10 Min



## INTRODUCTION

1. When a platoon or troops standing in any formation near the edge of the drill ground are required to be brought on parade, then the word of command '**Parade Par**' is used. Before the platoon is brought on parade the right marker is nominated. In a squad the squad commander, in a platoon the platoon Havildar and in a company the CHM is the right marker. When the troops are not required to fall in again and officer is present on parade then **Visarjan** action is done. When troops are required to be rested for some time and fall in again is supposed to be done, then **Line Tod** is done momentarily. In order to go from one place to another in an orderly and disciplined manner, **Tej Chal** is done. The length of the step is 30 inches. The speed of steps for Regiment/Units is 120 steps in a minute, for Rifle Units is 140 steps per minute, NCC Boy Cadets is 116 steps per minute and NCC Girl Cadets is 110 steps per minute. But, initially the recruits in Army march at a speed of 135 steps per minute.



### PREVIEW

This lecture will be conducted in five parts: -

1. Part I : *Parade Par.*
2. Part II : *Visarjan.*
3. Part III : *Line Tod.*
4. Part IV : *Tej Chal aur Tham.*
5. Part V : *Dhire Chal aur Tham.*

### LEARNING OBJECTIVES

- Need for *parade par, visarjan* and *line tod.*
- Demonstration by statement and count (*ginti aur bayan ke saath namuna*).
- Need of *tej chal aur tham* and *dhire chal aur tham.*
- Practice.



## PART I : PARADE PAR

2. **Need.** In a situation when a platoon or troops standing in any formation near the edge of the drill ground are required to be brought on parade, then the word of command '**Parade Par**' is used. Before the platoon is brought on parade, the right marker is nominated. In a squad, the squad commander; in a platoon, the platoon Havildar and in a company the CHM is the right marker. When the troops are not required to fall in again, and officer is present on parade, then '**Visarjan**' action is done. When troops are required to be rested for some time and again a fall in is to be done then the orders of '**Line Tod**' is given.

3. **Demonstration by Statement and Count (Bayan Aur Ginti se Namuna).**

(a) On receiving the word of command '**Squad Parade Par**' the squad will move forward and do '**Tham**' while taking alignment from Right Marker. They will then raise their right arm and get dressed and one by one put their arms down.

## PART II : VISARJAN

4. **Need.** When there is no need to do fall in of the troops (cadets) again, and the officers are present for the parade, then '**Visarjan**' is done.

5. **Demonstration by Statement and Count (Bayan Aur Ginti se Namuna).**

(a) When from '**Savdhan**' position word of command is received **Squad/Platoon 'Visarjan'**, then turn right, salute and take three steps forward, do '**Tham**' and keep moving straight. During practice turn left and remain standing in '**Savdhan**' position.

## PART III : LINE TOD

6. **Need.** When the squad is required to be given rest for a while and then are required to fall in again then **Line Tod** is done.

7. **Demonstration by Statement and Count (Bayan Aur Ginti se Namuna).**

(a) The process of '**Line Tod**' is similar to the one we have learnt for '**Visarjan**', but salute will not be done on doing '**Line Tod**'.

## PART IV : TEJ CHAL AUR THAM

8. **Need.** In order to go from one place to another in an orderly and disciplined manner, **Tej Chal** is done. The length of the step is 30 inches. The speed of steps for Regiment/Unit is 120 steps per minute, for Rifle Units it is 140 steps per minute, for NCC Boy Cadet it is 116 steps per minute and NCC Girl Cadets it is 110 steps per minute. But, during the initial part of training the recruits in Army march at a speed of 135 steps per minute.



9. **Demonstration by Statement and Count (Ginti aur Bayan se Namuna).**

(a) When you get the word of command from '**Savdhan**' position '**Ginti Se Chalna- Tej Chal- Ek**', then on this word of command place the left foot at a distance of 30 inches, the right arm to swing forward, in line with the shoulder, keep the left arm completely behind with fist closed, and watch the movement consciously till here. Things to observe in this position – the heel of the left foot is placed on the ground, toe raised, right foot completely on the ground, weight of the body on the right foot, both legs will be firm and taut without bending the knees, right arm in line with the shoulder and left hand behind, fists closed naturally. Rest of the position is as in '**Savdhan**'.

(b) When you receive the word of command '**Squad Do**' then on that word of command change feet and arms simultaneously and shout '**Do**'. In this position, the right heel is touching the ground, the toe is raised, the left foot is completely on the ground and the weight of the body is on the left foot, the left arm is behind the right arm.

(c) When the word of command is received '**Squad Ek**' then change arms and legs again.

(d) Word of command of '**Squad Tham**' is given, when left foot is on the ground or when the right foot is crossing the left foot, keep the right foot at 30 inches for the entire length and shout '**Khali**'. Then lift the left foot up and press down with the right foot, again quickly raising the right foot by 6 inches, placing it in '**Savdhan**' position with the left feet and shout '**Ek-Do**'. Things to observe in this position is similar to as that in '**Savdhan**' position.



**PART V : DHIRE CHAL AUR THAM**

10. **Need.** During ceremonial parades when the dignitary is inspecting the parade, the pilots marching ahead of the dignitary are required to do '**Dhire Chal**'. The length of the steps is 30 inches and the speed of the steps is 70 steps per minute.

11. **Demonstration by Statement and Count (Ginti aur Bayan se Namuna).**

(a) When you get the word of command of '**Kadam Tol Kar Dhire Chalna - Bayan Paon Aage**', then on this word of command move your left foot quickly by 15 inches, stop and shout **Aage**. Things to look for in this position - the right foot should be completely on the ground and the weight of the body should be on the right foot; left foot should be 15 inches ahead of the right foot, toe along the ground and should be pulled towards the ground. The rest of the position is same as '**Savdhan**' position.



(b) When you get the word of command '**Aage Badh**' then on this word of command raise your left foot 15 inches further forward and place your toe first on the ground and shout **Badho**. Things to see in this position - The left foot is completely placed on the ground, the weight of the body is completely on the left foot, the toe of the right foot is on the ground, both the legs are raised and firm, the rest of the position is like **Savdhan**.

(c) When you get the word of command '**Dahina Paon Aage**', then move your right foot 15 inches forward from your left foot and shout **Aage**.

(d) When you get the word of command, **Aage Badh**, move the right foot further 15 inches forward and put the toes on the ground first and shout **Badho**. This position is similar but opposite to left foot.

(e) When one gets the word of command '**Bayan Paon Aage**', then take the left foot forward and shout Aage as done before.

(f) When the word of command '**Tham**' is given at that time when the left foot is crossing the right foot or the right foot is on the ground, then taking the left foot 15 inches forward, lift and press it and quickly raise the right foot 6 inches and join it with the left foot and shout '**Ek-Do**'.



## CONCLUSION

12. When a platoon or troops standing in any formation near the edge of the drill ground are required to be brought on parade, then the word of command '**Parade Par**' is used. Before the platoon is brought on parade the right marker is nominated. In a squad the squad commander, in a platoon the platoon Havildar and in a company the CHM is the right marker. When the troops are not required to fall in again and officer is present on parade then '**Visarjan**' action is done. When troops are required to be rested for some time and fall in again then '**Line Tod**' is done.

13. In **Tej Chal (Quick March)**, Cadets should march from the position of **Savdhan** (applies to all occasions including **Parade Par**) with natural swing from the shoulder, hands reaching as high as shoulder level in front and/to the rear. Hand kept closed and fingers slightly clenched always to the front should be maintained. Legs should be straight and the knees should not be bent, swinging forward freely and naturally from the hip joints.

14. In **Dhire Chal (Slow March)**, Cadet should move their left leg forward balancing on the right foot. The cadets should move left leg till it reaches right foot. Maintaining balance on right foot, the cadet should move the left leg further ahead and place left foot on ground. The distance of one pace is 30 Inch. Similarly, cadets should put the right foot ahead and halt. Hands should remain by the side of the body as in '**Savdhan**' position.



## SUMMARY

- When a platoon or troops standing in any formation near the edge of the drill ground are required to be brought on parade then the word of command **Parade Par** is used.
- In a squad, the squad commander, in a platoon the platoon Havildar, and in a company the CHM is the right marker
- When the troops are not required to fall in again and officer is present on parade then '**Visarjan**' action is done.
- When troops are required to be rested for some time and fall in again then **Line Tod** is done.
- When from '**Savdhan**' position the word of command '**Visarjan**' is received, then turn right, salute, take three steps forward, and do **Tham**. Thereafter keep moving straight.
- The process of '**Line Tod**' is similar to the one we have learnt for '**Visarjan**', but salute will not be done on doing '**Line Tod**'.
- To go from one place to another while maintaining discipline, **Tej Chal** is done. Speed of steps for NCC Boy Cadets is 116 steps per minute and for NCC Girl Cadets is 110 steps per minute. However, Army recruits in the initial phase of training march at a speed of 135 steps per minute.
- When any dignitary is inspecting the parade, the pilots ahead of the dignitary are required to do **Dhire Chal**.
- '**Tham**' is given to stop any contingent during **Tej Chal/Dhire Chal**.



## ASSESSMENT EXERCISE

### Multiple Choice Questions

- Q1. What action is done to get cadets on parade?
- (a) *Parade Par* (b) *Line Tod*  
 (c) *Visarjan* (d) None of these
- Q2. What action is done to disperse cadets, not required to be fallin again?
- (a) *Parade Par* (b) *Line Tod*  
 (c) *Visarjan* (d) None of these
- Q3. What action is done when cadets are required to be rested for some time and fallin again?
- (a) *Parade Par* (b) *Line Tod*  
 (c) *Visarjan* (d) None of these
- Q4. Who is the Right Marker in a squad?
- (a) Squad Cdr (b) Platoon Hav  
 (c) Company Commander (d) CHM
- Q5. Who is the Right Marker in a platoon?
- (a) Squad Cdr (b) Platoon Hav  
 (c) Company Commander (d) CHM
- Q6. Who is the Right Marker in a company?
- (a) Squad Cdr (b) Platoon Hav  
 (c) Company Commander (d) CHM
- Q7. When from *Savdhan* position word of command is received cadets *Visarjan*, then :-
- (a) Turn right & salute (b) Turn left & salute  
 (c) Move forward & salute (d) Move backward & salute



Q8. The process of *Line Tod* is similar to the one for *Visarjan*, except in *Line Tod*.... :-

- (a) Salute will not be done (b) Turn left & salute  
(c) Move forward & salute (d) Move backward & salute

Q9. What is the pace of the Regiment/Units steps in one minute?

- (a) 120 (b) 140  
(c) 110 (d) 115

Q10. What is the speed of steps of the NCC Girl cadets in one minute?

- (a) 110 (b) 120  
(c) 130 (d) 125

Q11. What is the speed of steps of the NCC Boy cadets in one minute?

- (a) 116 (b) 130  
(c) 120 (d) 105

Q12. What is the distance between 2 cadets in *Tej Chal*?

- (a) 30 inch (b) 20 inch  
(c) 45 inch (d) 18 inch

Q13. How many inches should the feet extend in *Dhire Chal*?

- (a) 30 (b) 20  
(c) 45 (d) 18

Q14. When is the word of command of *Tham* given?

- (a) *Dahine paon par* (b) *Bayen paon par*  
(c) *Dono mein se kisi bhi paon par* (d) *Kisi par nahi*

Q15. In *Tej Chal* the length of each step is \_\_\_\_\_ inches.

- (a) 30 (b) 45  
(c) 60 (d) 75

Q16. During *Dhire Chal* how many steps per minute are taken?

- (a) 60 (b) 120  
(c) 90 (d) 70



- Q17. On *Tham* which is the leg we stamp last in the procedure?
- (a) Right leg (b) Left leg  
(c) No leg (d) Both legs
- Q18. In *Tej Chal* when left foot is in front which hand should be in front?
- (a) left hand (b) Both hands  
(c) No hand (d) Right hand

### Short Answer Questions

- Q1. Why do we do *Tej Chal*?
- Q2. What are the things to keep in mind while *Tej Chal* and *Tham*?
- Q3. What is the word of command for *Tej Chal* and *Tham*?
- Q4. Why is it necessary to do *Dhire Chal*?
- Q5. What is the need for *Tham* in *Tej Chal*?
- Q6. What is need for *Parade Par*?
- Q7. What is need for *Visarjan*?
- Q8. What is need for *Line Tod* ?
- Q9. What is the difference between *Visarjan* and *Line Tod*?

### Long Answer Questions

- Q1. Write the need for *Tej Chal* and the speed of movement of the Unit/Regiment?
- Q2. Write about *Tej Chal* and *Tham* in detail.
- Q3. What are the things to be kept in mind while *Tej Chal* and *Tham*?
- Q4. What is the word of command for *Dhire Chal* and *Tham*?
- Q5. Write in detail about *Parade Par*.
- Q6. Write in detail about *Visarjan*.
- Q7. Write in detail about *Line Tod*.



## FOOT DRILL (SD/SW)

### CHAPTER FD VI : TEJ CHAL SE MUDNA

*“Make Every Routine your Masterpiece”*



### TEACHING INSTRUCTIONS

<b>Total Periods</b>	: Four (04).
<b>Type</b>	: Lecture and Practice.
<b>Year</b>	: Ist Year - 02 Periods, IInd Year - 02 Periods.
<b>Conducting Officer</b>	: Permanent Instructor.
<b><u>Training Aids</u></b>	: Chart, Black Board & Training Video.

<b><u>Time Plan</u></b>		<b><u>Ist Year</u></b>	<b><u>IInd Year</u></b>
➤ Introduction/Recapitulation (Theory)	:	20 Min	20 Min
➤ <b><i>Tej Chal se Dahine Mudna</i></b> (Practical)	:	20 Min	20 Min
➤ <b><i>Tej Chal se Bayen Mudna</i></b> (Practical)	:	20 Min	20 Min
➤ <b><i>Tej Chal se Piche Mudna</i></b> (Practical)	:	10 Min	10 Min
➤ Revision/Consolidation (Theory/Practical)	:	10 Min	10 Min

## INTRODUCTION

1. When cadets are marching straight in the forward direction and have to change their orientation and direction by 90 degrees to the right or left then they are required to do ***Tej Chal se Dahine Mudna*** or ***Tej Chal se Bayen Mudna***. Similarly, if the cadets have to change their orientation by 180 degrees in the reverse direction then they will have to do ***Tej Chal se Piche Mudna***.



### PREVIEW

This lecture will be conducted in three parts:-

1. Part I : ***Tej Chal se Dahine Mudna.***
2. Part II : ***Tej Chal se Bayen Mudna.***
3. Part III : ***Tej Chal se Piche Mudna.***

### LEARNING OBJECTIVES

- Need and demonstration by statement and count
- ***Tej chal se dahine mudna.***
- ***Tej chal se bayen mudna.***
- ***Tej chal se piche mudna***



## PART I : TEJ CHAL SE DAHINE MUDNA

2. **Need.** When the cadets are marching straight in the forward direction and wish to change their direction and orientation by 90 degrees to the right then **Tej Chal se Dahine Mudna** is done.

3. **Demonstration by Statement and Count (Ginti aur Bayan se Namuna).**

(a) When the cadets are marching forward in '**Tej Chal**' and receive a word of command '**Ginti se Mudna Dahine Mud - Ek**' - this word of command will be given when right foot is crossing the left foot or left foot is on the ground. On this word of command the right foot is placed 15 inches ahead on the ground and the orientation is changed to the right and shout **Ek**. In this position right foot should be on the ground, weight on the toe of right foot, heel of the right foot raised, left hand ahead and right hand behind as in marching position.



(b) On receiving the word of command '**Squad Do**', then on this word of command left foot should be lifted ahead as in **Kadam Tal**, take the hands as in '**Savdhan**' position and shout **Do**. Point to remember in this position is that right foot should completely be on the ground, weight on right foot while left foot should be in position of **Kadam Tal** and rest of the position as in '**Savdhan**'.

(c) When the word of command '**Squad Teen**' is received, then turn on the heel of right foot by 90 degrees, get the left leg in '**Savdhan**' position and shoot the right leg 15 inches ahead as in **Kadam Tal** and shout **Teen**. In this position left foot should be completely on the ground, weight on left foot, right foot ahead by 15 inches as in **Kadam Tal** and rest of the position is similar to '**Savdhan**'.

(d) When the word of command '**Squad Char**' is received, then shoot the right foot 15 inches forward with the heel on the ground and commence **Tej Chal** simultaneously shouting **Badho**

## PART II : TEJ CHAL SE BAYEN MUDNA

4. **Need.** When cadets are marching forward and wish to change their direction and orientation by 90 degrees to the left then **Tej Chal se Bayen Mudna** is done.

5. **Demonstration by Statement and Count (Ginti aur Bayan se Namuna).**

(a) While marching when cadets receive the word of command '**Ginti se Mudna Bayen Mud - Ek**', then this word of command is given when the left foot is crossing



the right foot or the heel of the right foot is touching the ground. On this word of command the right foot is placed 15 inches ahead on the ground and stop in the marching position and shout **Ek**. In this position left foot should completely be on the ground, weight on left foot, toe of the right foot on the ground with heel raised, right arm in front and left hand behind as in **Tej Chal**.

(b) On receiving the word of command '**Squad Do**', right foot is lifted as in **Kadam Tal**, hands as in '**Savdhan**' position, and shout **Do**. In this position left foot should completely be on the ground, weight on left foot, right foot as in **Kadam Tal** and rest of the position as '**Savdhan**'.

(c) When cadets get the word of command '**Squad Teen**', then they turn 90 degrees on the heel of left foot, get the right foot to '**Savdhan**' position and shoot the left foot forward by 15 inches as in **Kadam Tal**. The rest of the position is like '**Savdhan**'.

(d) On receiving the word of command '**Squad Char**', the left foot is moved 15 inches forward with the heel touching the ground first and continue **Tej Chal** while shouting **Badho**.

### PART III : TEJ CHAL SE PICHE MUDNA

6. **Need.** When while marching forward cadets wish to change their orientation and formation by 180 degrees to the rear direction then **Tej Chal se Piche Mudna** is done.

7. **Demonstration by Statement and Count (Ginti aur Bayan se Namuna).**

(a) When cadets are marching in **Tej Chal** and receive the word of command '**Ginti se Mudna Piche Mud – Ek**' - this word of command is given when the left foot is crossing the right foot or the heel of the right foot is on the ground. On receiving this word of command, move right foot forward by 15 inches as in marching position and stop while shouting **Khali Ek**. This position is similar to the first movement of **Dahine Mud**.

(b) On receiving the word of command '**Squad Do**', then turn of the heel of the right foot towards the right by 90 degrees and get the left foot close to right foot as in '**Savdhan**' position and shout **Do**. This position is similar to '**Savdhan**' but the orientation must change by 90 degrees to the right.

(c) On receiving the word of command '**Squad Teen**' then on the right toe of left foot turn 90 degrees to the right simultaneously, lift the right foot by 6 inches coming to '**Savdhan**' position while shouting **Teen**. This position is similar to '**Savdhan**'.

(d) On receiving the word of command '**Squad Char**', correct the position and direction by lifting the left leg by 6 inches and placing close to right leg as in '**Savdhan**' position. This position is similar to '**Savdhan**' but the orientation has changed by 180 degrees.

(e) When cadets receive the word of command '**Squad Panch**', then cadets must shoot their left foot forward by 30 inches, start **Tej Chal** while shouting **Badho**.



## CONCLUSION

8. When cadets are marching in the forward direction and want to change their orientation by 90 degrees to the right or left then they will be required to do ***Tej Chal se Dahine Mudna*** and ***Tej Chal se Bayen Mudna***. Similarly, if they wish to change their orientation by 180 degrees in the reverse direction, then they will have to do ***Tej Chal se Piche Mudna***.

## SUMMARY

- When cadets are marching in the forward direction and want to change their orientation by 90 degrees to the right or left then they will be required to do ***Tej Chal se Dahine Mudna*** and ***Tej Chal se Bayen Mudna***. Similarly, if they wish to change their orientation by 180 degrees in the reverse direction, then they will have to do ***Tej Chal se Piche Mudna***.
- When cadets are marching forward and wish to change their direction and orientation by 90 degrees to the right then ***Tej Chal se Dahine Mudna*** is done.
- When cadets are marching forward and wish to change their direction and orientation by 90 degrees to the left then ***Tej Chal se Bayen Mudna*** is done.
- When while marching forward cadets wish to change their orientation and formation by 180 degrees to the rear direction then ***Tej Chal se Piche Mudna*** is done.



## ASSESSMENT EXERCISE

### Multiple Choice Questions

- Q1. By how many degrees does the orientation change to the right in **Dahine Mud** ?
- (a) 90 (b) 40  
(c) 75 (d) 45
- Q2. By how many degrees does the orientation change when , **Piche Mud** from **Tej Chal** is done ?
- (a) 180 (b) 120  
(c) 130 (d) 125
- Q3. How many inches ahead of the ground should one place the right foot while doing **Dahine Mud** ?
- (a) 16 (b) 15  
(c) 30 (d) 20
- Q4. After two consecutive **Bayen Ghoom** orders while marching, you will be moving in which direction?
- (a) Right (b) Opposite  
(c) Left (d) Same
- Q5. During **Tej Chal** \_\_\_\_\_ movements are taken for **Dahine Mud**.
- (a) 3 (b) 4  
(c) 5 (d) 6
- Q6. During **Tej Chal** \_\_\_\_\_ movements are taken for **Piche Mud**.
- (a) 3 (b) 4  
(c) 5 (d) 6
- Q7. During **Tej Chal** \_\_\_\_\_ movements are taken for **Bayen Mud**.
- (a) 3 (b) 4  
(c) 5 (d) 6
- Q8. During **Tej Chal** the word of command of **Bayen Mud** is given on \_\_\_\_\_ leg.
- (a) Left (b) Right  
(c) Both (d) None of these



Q9. During **Tej Chal** the word of command of **Dahine Mud** is given on \_\_\_\_\_ leg.

- (a) Left (b) Right  
(c) Both (d) None of these

Q10. During **Tej Chal** the word of command of **Piche Mud** is given on \_\_\_\_\_ leg.

- (a) Left (b) Right  
(c) Both (d) None of these

### Short Answer Questions

Q1. Why is **Tej Chal se Dahine aur Bayen Mud** required?

Q2. Why is **Tej Chal se Piche Mud** required?

Q3. What are the things to look for in **Tej Chal se Dahine aur Bayen Mud**?

Q4. What is the word of command for **Tej Chal se Piche Mud**?

Q5. Which leg do we shoot after doing **Piche Mud**?

### Long Answer Questions

Q1. Write the order of **Tej Chal se Dahine Mud**?

Q2. Write the order of **Tej Chal se Bayen Mud**?

Q3. Write the order of **Tej Chal se Piche Mud**?

Q4. What are the things to be kept in mind while doing **Tej Chal se Dahine aur Bayen Mud**?

Q5. What are the important things in the process of **Tej Chal se Piche Mud**?



## FOOT DRILL (SD/SW)

### CHAPTER FD VII : TEJ CHAL SE SALUTE KARNA

*“Practice with Intensity, Compete with Integrity, Lose with Dignity  
Win with Humility”*



#### TEACHING INSTRUCTIONS

**Total Periods** : Five (05).

**Type** : Lecture and Practice.

**Year** : Ist Year - 02 Periods & IInd Year - 03 Periods.

**Conducting Officer** : Permanent Instructor.

**Training Aids** : Chart, Black Board & Training Video.

<u>Time Plan</u>	<u>Ist Yr</u>	<u>IInd Yr</u>
➤ Introduction /Recapitulation (Theory) :	10 Min	15 Min
➤ Tej Chal se Samne Salute (Practical) :	20 Min	30 Min
➤ Tej Chal se Dahine Salute (Practical) :	20 Min	30 Min
➤ Tej Chal se Bayen Salute (Practical) :	20 Min	30 Min
➤ Revision/Consolidation (Theory/Practical) :	10 Min	15 Min



## INTRODUCTION

1. Whenever we have to interact with any Senior Armed Forces Officer or any distinguished dignitary, to give them respect, we salute them smartly. Similarly while marching, when the squad passes in front of the reviewing dais the squad commander gives a salute while on the march. Salutes are reciprocated at the highest levels upto and including Heads of States and are indicative of a feeling of mutual trust and respect. Thus we can say that Salute is a courteous exchange of greetings between junior and senior ranking individuals and it is also rendered to the National Flag as a sign of respect.



### PREVIEW

This lecture will be conducted in three parts:-

1. Part I : Tej Chal se Samne Salute Karna.
2. Part II : Tej Chal se Dahine Salute Karna.
3. Part III : Tej Chal se Bayen Salute Kana

### LEARNING OBJECTIVES

- Understand and learn *tej chal se salute karna*



## PART I : TEJ CHAL SE SAMNE SALUTE KARNA

2. **Need.** Saluting is a military custom by which respect is given to a superior rank or a dignitary and also to greet or acknowledge their presence. Salute is also rendered to the National Flag as a sign of respect.

3. **Demonstration by Statement and Count (Ginti aur Bayan se Namuna).**

(a) When from **Tej Chal** cadet gets a word of command '**Ginti se Salute Karna Samne Salute - Ek**'. This word of command is given in a similar manner as while doing **Tham** in **Tej Chal**. This position is similar to '**Savdhan**'.

(b) When you get a word of command '**Squad Do**', on this word of command, do '**Samne Salute**' once. In this position cadet should have completed the **Samne Salute** and the rest of the position is same as '**Savdhan**'.

(c) When cadet gets a word of command '**Squad Teen**'. On this word of command, do **Samne Salute** once again. The rest of the position is like **Savdhan**.

(d) When the word of command '**Squad Char**' is given, then on this word of command **Piche Mud is done**. In this position cadets direction should have changed by 180 degrees. The rest of the position is like '**Savdhan**'.

(e) When the cadet gets the word of command '**Squad Panch**', then the cadet starts **Tej Chal** and shouts **Badho**.



## PART II : TEJ CHAL SE DAHINE SALUTE KARNA

4. **Need.** When a cadet is marching and any Officer or a dignitary is passing from the right then the cadet is required to do **Dahine Salute**.

5. **Demonstration by Statement and Count (Ginti aur Bayan se Namuna).**

(a) When from **Tej Chal** a cadet gets a word of command **Ginti se Salute Karna Dahine Salute - Ek**, then cadet is required to do **Dahine Salute**. This word of command is given when right foot is crossing the left foot or heel of left foot is on the ground. On receiving this command, as the heel of the left feet touches the ground, the cadet turns their head right, salutes and stops while shouting **Khali Ek**. In this position heel of the left foot should be on the ground, right foot completely on the ground, weight on right





foot, both legs are firm and taut, salute as per procedure , eyes completely right and rest of the position like in **Savdhan**.

(b) When cadet gets a word of command **Squad Do**, then, on the right foot start the count from 2 and count till 5 while continuing to march and then stop. The count should be like '**Squad Do**' - **Do** - **Teen** - **Char** - **Panch**. In this position the cadet should have covered five steps forward and rest of the position is like described above.

(c) On receiving the word of command **Squad Teen**, the cadet takes the right foot forward with the heel touching the ground and simultaneously looks straight and drops the salute (saluting hand) while shouting **down**. In this position the heel of the right foot should be 30 inches ahead, toe up, weight on left foot, salute down and rest of the position like **Savdhan**.

(d) When cadet gets the word of command **Squad Char** , then commence **Tej Chal** from left foot and shout **Badho**.

### **PART III : TEJ CHAL SE BAYEN SALUTE KARNA**

6. **Need.** When a cadet is marching and any Officer or a dignitary is passing from the left, then the cadet is required to do **Bayen Salute**.

7. **Demonstration by Statement and Count (Ginti aur Bayan se Namuna).**

(a) When from **Tej Chal** a cadet gets a word of command **Ginti se Salute Karna Bayen Salute – Ek**, then cadet is required to do **Bayen Salute**. This word of command is given when right foot is crossing the left foot or heel of left foot is on the ground. On receiving this command as the heel of the left foot touches the ground the cadet turns the head left, salutes and stops while shouting **Khali Ek**. In this position heel of the left foot should be on the ground, right foot completely on the ground, weight on left foot, both legs are firm and taut, salute as per procedure taught, eyes completely left and rest of the position like **Savdhan**.

(b) When cadet gets a word of command **Squad Do** then on the right foot start the count from 2 and count till 5 while continuing to march and then stop. The count should be like '**Squad Do**' - **Do** - **Teen** - **Char** - **Panch**. In this position a cadet should have covered five steps forward and rest of the position is like described above.

(c) On receiving the word of command **Squad Teen** ,the cadet takes the right foot forward with the heel touching the ground and simultaneously looks straight and drops the salute (saluting hand) while shouting **down**. In this position the heel of the right foot should be 30 inches ahead, toe up, weight on left foot, salute down and rest of the position like **Savdhan**.





- (d) When a cadet gets the word of command **Squad Char**, then commence **Tej Chal** from left foot and shout **Badho**.

## CONCLUSION

8. A salute is imparted to Senior Armed Forces Officer or any distinguished dignitary, to give them respect. Similarly while marching, when the squad passes in front of the reviewing dais the squad commander gives a salute while on the march. Salutes are reciprocated at the highest levels upto and including Heads of States and are indicative of a feeling of mutual trust and respect. Thus we can say that Salute is a courteous exchange of greetings between junior and senior ranking individuals. Salute is also rendered to the National Flag as a sign of respect.

## SUMMARY

- Whenever a cadet or a junior has to talk to any Officer or a dignitary, or if these dignitaries have called for any interaction, then they are saluted smartly as a mark of respect. Similarly, while marching when the squad passes in front of the reviewing dais the squad commander gives a salute while marching.
- When a cadet is marching and any officer/rank holder is passing from the right, then a **Dahine Salute** is required to be done.
- When a cadet is marching and any officer/rank holder passes from the left, then **Bayen Salute** is required to be done.

**ASSESSMENT EXERCISE****Multiple Choice Questions**

- Q1. How many movements are there in *Tej Chal se Samne Salute*?
- (a) 5 (b) 4  
(c) 3 (d) 2
- Q2. How many inches does the feet extend while doing *Tej Chal se Dahine Salute*?
- (a) 30 (b) 20  
(c) 10 (d) 12
- Q3. What is the angle between the right hand and the elbow while doing *Dahine salute*?
- (a) 45 (b) 30  
(c) 20 (d) 25
- Q4. How many movements are there in *Tej Chal se Bayen Salute*?
- (a) 4 (b) 5  
(c) 7 (d) 2
- Q5. On which foot is the word of command *Dahine Salute* given?
- (a) On right foot (b) On left foot  
(c) Both feet (d) None of these
- Q6. How many types of *Khali Hath Salute* are there?
- (a) 3 (b) 5  
(c) 7 (d) 2
- Q7. During *Tej Chal*\_\_\_\_\_ movements are taken for *Dahine Salute*.
- (a) 3 (b) 4  
(c) 5 (d) 6
- Q8. During *Tej Chal*\_\_\_\_\_ movements are taken for *Bayen Salute*.
- (a) 3 (b) 4  
(c) 5 (d) 6



Q9. During *Tej Chal* the Word of Command of *Bayen Salute* is given on \_\_\_\_ leg.

- (a) Left (b) Right  
(c) Both (d) None of these

Q10. During *Dahine Salute/ Bayen Salute* how many steps do we move in *Tej Chal*?

- (a) 8 (b) 4  
(c) 5 (d) 6

### **Short Answer Questions**

- Q1. Why *Samne Salute* is needed?  
Q2. Why *Tej Chal se Dahine Salute* is needed?  
Q3. What are the things to look for when doing *Samne Salute*?  
Q4. When do we do *Bayen Salute*?  
Q5. How many times should we salute in *Samne Salute*?

### **Long Answer Questions**

- Q1. Write down the procedure for *Samne Salute*?  
Q2. Write down the procedure for *Tej Chal se Dahine Salute*?  
Q3. Explain *Bayen Salute*.  
Q4. What are the points to be kept in mind in *Dahine Salute*?  
Q5. What are the points to be kept in mind in *Bayen Salute*?



## FOOT DRILL (SD/SW)

### CHAPTER FD VIII : TEJ KADAM TAL SE KADAM BADALNA

“Great Things are never found in your Comfort Zone”



### TEACHING INSTRUCTIONS

<b>Total Periods</b>	:	Two (02)
<b>Type</b>	:	Lecture and Practice
<b>Year</b>	:	Ist Year - 02 Periods
<b>Conducting Officer</b>	:	Permanent Instructor
<b><u>Training Aids</u></b>	:	Chart, Black Board & Training Video.

#### Time Plan

#### Ist Year

➤ Introduction (Theory)	:	10 Min
➤ Tej Kadam Tal se Kadam Badalna	:	30 Min
➤ Practical	:	30 Min
➤ Revision/Consolidation	:	10 Min

## INTRODUCTION

1. Marching in correct rhythm is very important for all forms of drill. *Kadam Tal* is done to warm up before commencing any drill. However, when the cadets are doing *Kadam Tal*, and if any cadet out of the lot is not in sync and their steps don't match with the other cadets of the squad, then the cadet is supposed to do *Kadam Badal* to get back to correct step with the rest of the squad.



### PREVIEW

This lecture will be conducted in One Part:-

1. ***Tez Kadam Tal Se Kadam Badalna***

### LEARNING OBJECTIVES

1. ***Tez kadam tal se bayen aur dahine kadam badal***

## PART I : TEJ KADAM TAL SE KADAM BADALNA

2. **Need.** When cadets are doing *Kadam Tal* and if any cadets step is not in sync and is different from the squad, then the cadet has to do *Kadam Badal* to get back in sync and match the correct step with the rest of the squad.



### 3. Demonstration by Statement and Count (*Bayan aur Ginti Se Namuna*).

(a) This word of command is given when left or right foot is on the ground. When cadets are doing **Tej Chal** and they receive a word of command **Kadam Badal**, then they do **Kadam Tal** twice on the foot that is required to be changed and on the other foot shout **Badal**. For example, if a cadet wants to change the left foot, then shout , **Bayen Bayen Dahine**.

(b) Word of Command - **Tej Kadam Tal, Bayen Dahina Kadam Badal - Bayen Bayen Dahina Squad Tham - Ek - Do**. In this position the cadet should have corrected his/her left foot which was out of sync and rest of the position is like **Savdhan**.

## CONCLUSION

4. **Tez Kadam Tal se Kadam Badalna** is used to get back to correct step if any member of the Squad is out of sync from others.

## SUMMARY

- When the cadets are doing **Kadam Tal** and if any cadet is out of sync from the squad, then he/she does **Kadam Badal** to get back to correct step with the rest of the squad.
- This word of command is given when left or right foot is on the ground. When a cadet is doing **Tej Chal** and if they receive a word of command **Kadam Badal**, then they do **Kadam Tal** twice on the foot that is required to be changed and on the other foot shout **Badal**. For example, if you a cadet wants to change the left foot, then shout **Bayen Bayen Dahine**.



## ASSESSMENT EXERCISE

### Multiple Choice Questions

- Q1. On which leg is the word of command of ***Kadam Badal*** given?
- (a) Left leg (b) Right leg  
(c) Both legs (d) None of these
- Q2. What action is done when a cadet gets out of step in ***TEJ CHAL***?
- (a) *Hath badal* (b) *Kadam Badal*  
(c) *Dahina paon badal* (d) *Baya paon badal*

### Short Questions

- Q1. Why do you require *Kadam Badal* from *Kadam Tal*?
- Q2. What is the word of command for *Kadam Badal* from *Tej Kadam Tal*?
- Q3. On which leg is the word of command for *Kadam Badal* from *Tej Kadam Tal* given?

### Long Answer Questions

- Q1. Write down the procedure for *Tej Kadam Tal Se Kadam Badal*?
- Q2. What are the points to be kept in mind for doing *Kadam Badal From Tej Kadam Tal* ?



## FOOT DRILL (SD/SW)

### CHAPTER FD IX : TEEN 'O' TEEN SE EK FILE AUR EK FILE SE TEEN 'O' TEEN BANANA AND DST PROCEDURE

“Success is a journey that requires Patience,  
don't quit before you reach your Goal”



### TEACHING INSTRUCTIONS

<b>Total Periods</b>	:	Two (02).
<b>Type</b>	:	Lecture and Practice.
<b>Year</b>	:	Ist Year - 02 Periods
<b>Conducting Officer</b>	:	Permanent Instructor.
<b><u>Training Aids</u></b>	:	Chart, Black Board & Training Video.

#### Time Plan

		<b><u>Ist Year</u></b>
➤ Introduction (Theory)	:	10 Min.
➤ <b>Teen 'O' Teen Se Ek File Banana</b> (Practical)	:	30 Min.
➤ <b>Ek File Se Teen 'O' Teen Banana</b> (Practical)	:	30 Min.
➤ Drill Square Test Procedure	:	10 Min



## INTRODUCTION

1. When cadets are marching in three files and are required to pass through a narrow passage, a bridge, or enter into a classroom then they are required to change formation from three files to a single file (***Teen - 'O' - Teen Se Ek File***). On exiting the bridge, or the narrow passage, the reverse action is done i.e. (***Ek File Se Teen - 'O' - Teen***).



### PREVIEW

This lesson will be conducted in three parts:-

1. Part I : ***Teen - 'O' - Teen Se Ek File Banana.***
2. Part II : ***Ek File Se Teen - 'O' - Teen Banana.***
3. Part III : ***Drill Square Test Procedure***

### LEARNING OBJECTIVES

- ***Teen O Teen Se Ek File and Drill Square Test (DST) procedure.***

## PART I: TEEN 'O' TEEN SE EK FILE BANANA

2. **Need.** When cadets are marching in three files and are required to pass through a narrow passage, a bridge, or enter into a classroom then they are required to change formation from three files to a single file (***Teen - 'O' - Teen Se Ek File***). On exiting the bridge, or the narrow passage, the reverse action is done i.e. (***Ek File Se Teen - 'O' - Teen***).

3. **Demonstration with Statement.** When cadets are marching in three files and they get a word of command "***Ek File Banana – Agli Line Tej Chal***" then the front line starts marching in ***Tej Chal***. When the last cadet of the front line passes near the center line, then the center line starts marching in ***Tej Chal***. In a similar manner the last line also starts marching behind the middle line and the complete squad gets into a single file.



## PART II: EK FILE SE TEEN O TEEN BANANA

4. **Demonstration with Statement.** When cadets are marching in a single file and get a word of command "**Squad Teen 'O' Teen Banaye Ga – Madhya aur Pichli Line Tej Chal**", then middle and last line will march in **Tej Chal** and stand at their designated place. The bayonet of the rifle should be on the bayonet stud if marching with rifle. In this position all the four fingers of the left hand should be straight and joined with the thumb, left hand straight, bayonet on the rifle. On receiving the word of command '**Squad Savdhan**', pull the rifle back as in '**Savdhan**'. This position is similar to '**Savdhan**'.



## PART III: DST PROCEDURE

5. **Need.** This procedure is required when a cadet or a soldier is required to undertake a Drill Square Test.

6. **Procedure.** When a cadet gets a word of command '**Samiksha Kram mein Madhya se Tej Chal**', then the cadet marches in **Tej Chal** for 14 steps and do **Tham**. After **Tham**, cadets are required to do **Samne Salute** and report in the following manner- "**Srimaan Cdt xxxxx DST keliye Hajir Hai**". After reporting, drill movements are performed in the following sequence. **Savdhan, Vishram, Dahine Mud, Bayen Mud, Piche Mud, Khuli line Chal, Nikat Line Chal, Dahine Mud and Tej Chal**. After completing 4 steps do **Bayen Salute**, after 5 steps put the salute down and after completing another 4 steps do **Piche Mud**, and continue to do **Tej Chal**. After marching for 4 steps do **Dahine Salute** and after completing another 5 steps put the salute down and do **Tham**. After the above procedure is over, do 4 steps of **Dhire Chal** and again do **Tham**. After this do the procedure of **Line Tod** and keep marching ahead.



## CONCLUSION

7. **Teen - O - Teen Se Ek File** is resorted to when the space does not permit movement of three files. The DST procedure is done when a cadet is required to undergo a Drill Square Test.

## SUMMARY

- When cadets are marching in three files and are required to pass through a narrow passage, a bridge or enter into a classroom then they are required to change formation from three files to a single file (**Teen – 'O' - Teen se Ek File**). On exiting the bridge, the reverse action is done i.e. (**Ek File se Teen - 'O' - Teen**).
- The DST procedure is required when a cadet or a soldier is required to undertake a Drill Square Test.

**ASSESSMENT EXERCISE****Multiple Choice Questions**

- Q1. What action is done when cadets are required to cross a bridge or narrow passage?
- (a) *Teen se Ek File Banana* (b) *Ek File Banana*  
(c) *Do File Banana* (d) None of the above
- Q2. What is the word of command for *Teen 'O' Teen se Ek File Banana*?
- (a) *Ek File Banana* (b) *Teen File Banana*  
(c) *Do File Banana* (d) *Char File Banana*
- Q3. What is the full form of DST?
- (a) Drill Study Test (b) Drill Selection Type  
(c) Drill Sequence Test (d) Drill Square Test
- Q4. How many steps do we take on command of *Samiksha Kram mein Madhya se Tej Chal* ?
- (a) 13 (b) 14  
(c) 15 (d) 16
- Q5. When we have to pass through a narrow passage, we move in \_\_\_\_\_ file.
- (a) Double File (b) Single File  
(c) Triple file (d) All of the above
- Q6. After doing *Samiksha Kram mein Madhya se Tej Chal* what salute is to be done?
- (a) Dahine Salute (b) Bayen Salute  
(c) Samne Salute (d) All of the Above
- Q7. During DST procedure we have to salute \_\_\_\_\_ times.
- (a) One (b) Three  
(c) Two (d) All of the above



Q8. In DST How many types of Salute is tested?

- |           |          |
|-----------|----------|
| (a) One   | (b) Five |
| (c) Three | (d) Two  |

Q9. On receiving word of command of *Squad "Teen 'O' Teen Banaye Ga"* which lines move?

- |                        |                      |
|------------------------|----------------------|
| (a) Middle & Last Line | (b) Middle line Only |
| (c) First & Last Line  | (d) First Line Only  |

Q10. What is the last procedure of DST?

- |                      |                          |
|----------------------|--------------------------|
| (a) <i>Line Tod</i>  | (b) <i>Samney Salute</i> |
| (c) <i>Piche Mud</i> | (d) <i>Tham</i>          |

### **Short Answer Questions**

Q1. When are you required to make *Teen o Teen se Ek File*?

Q2. Write about the procedure of doing *Ek File se Teen o Teen*?

Q3. What is the word of command for changing from *Teen o Teen se Ek File*?

Q4. What is the word of command for changing from *Ek File se Teen o Teen*?

### **Long Answer Questions**

Q1. Write about the procedure of changing from *Teen o Teen se Ek File*?

Q2. What are the points to be observed while doing *Ek File se Teen o Teen*?

Q3. Write down the sequence of DST procedure?



## FOOT DRILL (SD/SW)

### CHAPTER FD X : INDIVIDUAL WORD OF COMMAND

*“Discipline is the Bridge between Goals and Success”*



### TEACHING INSTRUCTIONS

**Total Periods** : Two (02).

**Type** : Practice.

**Year** : II nd Year - 02 Periods.

**Conducting Officer** : Permanent Instructor.

**Training Aids** : Chart, Black Board & Training Video.

#### Time Plan

#### II nd Year

(a) Introduction (Theory)	: 10 Min
(b) Words of Command (Practical)	: 30 Min
(c) Practice (Practical)	: 30 Min
(d) Revision/Consolidation (Theory/Practical)	: 10 Min



## INTRODUCTION

1. A good word of command depends upon the voice **tone** and **pitch**. **Correct** word of command is given in **clear** and **loud** voice. A good word of command is **promptly** acted upon.



### PREVIEW

This lecture will be conducted in two parts:-

1. **Part I : Words of Command ki Jankari.**
2. **Part II : DST Procedure**

### LEARNING OBJECTIVES

- **Know about word of command.**
- **Practice DST procedure.**



## PART I : WORDS OF COMMAND

2. A correct word of command depends on the “**tone and pitch**” of the voice. A good word of command is given in a “**clear and loud voice**” so that it is implemented immediately. The following things are important for giving a good word of command:-



(a) **Loudness (Swar).** The loudness of word of command depends upon how many people are receiving the same and what is their distance from the commander. For giving a word of command the commander always positions him self in **front** of the squad and in the **centre**. Word of command is always given in **Savdhan**.

(b) **Clarity (Spashta).** Clear word or command is given when there is correct coordination between the **tongue, lips** and the **teeth**.

A clear word of command will be **promptly** acted upon.

(c) **Pitch.** For correct word of command the **correct pitch** is essential.

(d) **Timing.** For prompt action to a word of command correct timing is essential. A word of command has two parts ie. **Cautionary** and **Executive**. Cautionary command is given as the preparatory command for the cadet to be ready for the Executive command which is the actual command to which a cadet has to respond. There should be a difference of **four Tej Kadam** steps between **Cautionary** and **Executive** words of command. In **Tej Chal** , **Cautionary** word of command starts from the **right foot**. There should be a **three** Second gap between the ‘**Cautionary**’ and ‘**Executive**’ word of command.

3. Following words of commands are used in drill:-

(a) **SAVDHAN and VISHRAM.**

(b) **DAHINE MUD and BAYEN MUD.**

(c) **PICHE MUD and AAGE MUD.**

(d) **DAHINE DEKH and BAYEN DEKH.**

(e) **TEJ CHAL, DHIRE CHAL and THAM.**

(f) **KHULI LINE CHAL and NIKAT LINE CHAL.**

(g) **LINE BAN, SAJ JA and VISARJAN.**

(h) **DAHINE SALUTE, BAYEN SALUTE and SAMNE SALUTE.**



## PART II : DRILL SQUARE TEST (DST) PROCEDURE

4. **Need.** After the completion of drill training, cadets have to undergo Drill Square Test to find out the level of efficiency acquired by **the cadets in drill.**
5. Demonstration with Statement.

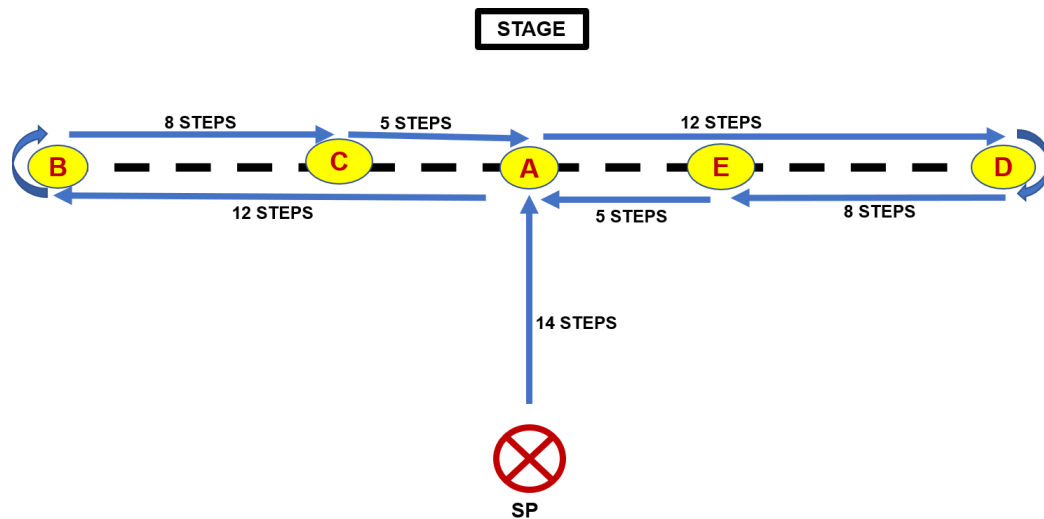

**Diagrammatic Layout of DST Procedure**

- (a) Get in **Savdhan** position.
- (b) On the order of **Shuru Karo**, march 14 steps with **Tej Chal** and do **Tham**.
- (c) **Salute** and give report to the instructor. **No \_\_\_\_\_ Cadet \_\_\_\_\_ DST Ke Liye Hazir Hai Shriman.**
- (d) Do **Dahine Mud**, one-time **Bayen Mud**, **Picche Mud** and again **Pichhe Mud**.
- (e) Then the drills of **Khuli Line** and **Nikat Line Chal** is done.
- (f) Do 12 Steps **Tej Chal** and **Pichhe Mud** and after 8 Steps do **Bayen Salute** with **Tej Chal**. Salute down after 5 steps.
- (g) Continue with **Tej Chal** and after 12 steps do the drill of **Pichhe Mud**. Again after 8 x steps do **Dahine Salute** and salute down after 5 steps with **Tej Chal**.
- (h) **Continue with Tej Chal** and after 4 steps do **Tham**. Do **Bayen Mud** followed by **Line Tod**.

## CONCLUSION

6. A good word of command depends upon the voice **tone** and **pitch**. **Correct** word of command is given in **clear** and **loud** voice. A good word of command is promptly acted upon.



## SUMMARY

- A good word of command depends upon the voice **tone** and **pitch**. **Correct** word of command is given in **clear** and **loud** voice. A good word of command is **promptly** acted upon.
- For giving a word of command the commander always positions himself in **front** of the squad and in the **centre**.
- A word of command has two parts. viz **Cautionary** and **Executive**.
- There should be a difference of four '**TEJ CHAL**' steps between **Cautionary** and **Executive** words of command.



## ASSESSMENT EXERCISE

### Multiple Choice Questions

Q1. Correct word of command depends on?

- |             |                      |
|-------------|----------------------|
| (a) Clarity | (b) Timing           |
| (c) Pitch   | (d) All of the above |

Q2. Word of commands are of \_\_\_\_\_ types.

- |       |       |
|-------|-------|
| (a) 3 | (b) 4 |
| (c) 2 | (d) 5 |

Q3. Good word of command depends on?

- |                       |                       |
|-----------------------|-----------------------|
| (a) Tone and pitch    | (b) Voice and timing  |
| (c) Clarity and pitch | (d) None of the above |

Q4. A properly delivered 'Command' is \_\_\_\_\_ and distinct enough to be clear and understood by every one.

- |          |           |
|----------|-----------|
| (a) Slow | (b) Heavy |
| (c) Long | (d) Loud  |

Q5. Word of Command is always given in \_\_\_\_\_ position.

- |             |             |
|-------------|-------------|
| (a) Savdhan | (b) Vishram |
| (c) Front   | (d) Janch   |

Q6. The Number of gap in 'Paces' between 'Cautionary' and 'Executive' Word of Command is \_\_\_\_\_.

- |       |       |
|-------|-------|
| (a) 3 | (b) 1 |
| (c) 2 | (d) 4 |

Q7. There should be a \_\_\_\_\_ Second gap between the Cautionary' and 'Executive' word of command.

- |       |       |
|-------|-------|
| (a) 1 | (b) 2 |
| (c) 3 | (d) 4 |



Q8. After getting the order of Shuru Kar how many steps does a cadet march before doing Tham?

- |              |              |
|--------------|--------------|
| (a) 10 steps | (b) 12 steps |
| (c) 14 steps | (d) 16 steps |

Q9. What is the full form of DST?

- |                       |                       |
|-----------------------|-----------------------|
| (a) Drill Square Test | (b) Drill Step Test   |
| (c) Dahine Step Test  | (d) Drill Square Time |

### **Short Answer Questions**

- Q1. What does a good word of command depend upon?
- Q2. What are the types of word of command?
- Q3. What all should be adhered for giving Clear word of command ?
- Q4. Word of Command should be given from which place ?
- Q5. Explain any one type of word of command.

### **Long Answer Questions**

- Q1. What do you understand by following in word of command?
- |              |
|--------------|
| (a) Loudness |
| (b) Clarity  |
| (c) Pitch    |
| (d) Timing   |
- Q2. How many types of words of command are there in drill. Explain.
- Q3. Make a diagram of DST procedure.



# **ARMS DRILL AND** **CEREMONIAL** **DRILL**

**2**



### **CHAPTER WISE INDEX: AD (SD/SW)**

<b>Ser No</b>	<b>Subject</b>	<b>Page</b>
1.	Chapter I: Savdhan, Vishram and Aram se with Rifle	67
2.	Chapter II: Parade Par and Saj Drill with Rifle	74
3.	Chapter III: Visarjan and Line Tod with Rifle	80
4.	Chapter IV: Bhumi Shahstra and Uthao Shastra	85
5.	Chapter V: Bagal Shastra and Baju Shastra	91
6.	Chapter VI: Salami Shastra, Baju Shastra and Ceremonial Drill	97
7.	Chapter VII: Squad Drill and DST Procedure with Rifle	119

## ARMS DRILL (SD/SW)

### CHAPTER AD I: SAVDHAN, VISHRAM & ARAM SE WITH RIFLE

“Dream is not that which you see while sleeping. It is something that does not let you sleep”



### TEACHING INSTRUCTIONS

<b>Period</b>	:	One (01)
<b>Type</b>	:	Lecture and Practice
<b>Year</b>	:	Ist Year – 01 Period
<b>Conducting Officer</b>	:	Permanent Instructor
<b><u>Training Aids</u></b>	:	Black Board, Chart, Video & DP Rif

<b><u>Time Plan</u></b>		<b><u>Ist Year</u></b>
➤ Gen Statement & Demonstration	:	10 Min.
➤ Practice of <b>Savdhan</b> , Vishram and Aram se with rifle	:	30 Min.



## INTRODUCTION

1. Rifle Drill is a Ceremonial Drill applicable only for Senior Division and Senior Wing cadets. It is performed to enhance discipline, coordination, and precision. Its purpose is to instill respect for military tradition, improve the soldier's physical fitness, and teach teamwork and focus. By practicing these movements, soldiers develop attention to detail, improve posture, and foster a sense of unity within their unit. Rifle drills are also used to prepare troops for combat situations by honing their ability to move efficiently and maintain control of their weapon while in formation.

2. '**Savdhan**' and '**Vishram**' are the basics of Rifle Drill. To learn further actions of rifle drill, it is very important to first know about '**Savdhan**' and '**Vishram**'. Point to be noted here is that the Rifle is always held in the right hand, while in '**Vishram**' position the right hand palm should be above the left hand palm.



### PREVIEW

This lesson will be conducted in three parts:-

- Part I : *Savdhan* with Rifle.
- Part II: *Vishram* aur *Aaram Se* with Rifle.

### LEARNING OBJECTIVES

- *Savdhan* drill with rifle.
- *Vishram* drill with rifle.
- *Aaram Se* drill with rifle.



## PART I: SAVDHAN WITH RIFLES

3. **Need.** When we have a rifle in hand and we want to talk to a senior or if we have to start any weapon handling activity, then we start from '**Savdhan**' position. In 'Savdhan' position the angle formed by both the feet at the ankle is 45 degrees.
4. **Demonstration by Statement and Count (*Bayan Aur Ginti se Namuna*).** When you get the word of command '**Savdhan**', then move your feet (in the manner learnt) on this word of command. With the right hand, pull the rifle fully back to your side so that butt of the rifle is resting flat on the ground and the rifle is aligned to the toe and with the side stitching of the trouser and shout '**EK**'.

## INTERESTING FACTS OF DRILL

- Drill was conceptualized by Major Gen Dral of Germany.

## PART II: VISHRAM AND AARAM SE WITH RIFLE

5. **Need.** When there is no requirement to do 'fall in' for the cadets or any action thereafter again in the Parade, then after '**Vishram**'/'**Aaram Se**', the command '**Visarjan**' is given. In '**Vishram**' position the distance between both feet, between the toes is 18 inches, while the distance between the heels is 12 inches.
6. **Demonstration by Statement and Count (*Bayan Aur Ginti se Namuna*).** When from '**Savdhan**' position word of command '**Visarjan**' is received by **Squad or Platoon**, then turn right, salute and take three steps forward, do '**Tham**' and keep moving straight. During practice, turn left and remain standing in '**Savdhan**' position.



**Savdhan Position**



**Vishram Position**



## CONCLUSION

7. '**Savdhan**' and '**Vishram**' is the first step towards good weapon drill. With the practice of this drill, we learn the correct procedure of standing in '**Savdhan**' and '**Vishram**' position with rifle.

## SUMMARY

Legs will be open in '**Vishram**' position and in '**Savdhan**' position, legs will be closed and heels will also be closed. Body weight to be balanced on both feet equally in both '**Savdhan**' and '**Vishram**' position. Never stand on one leg during drill.



## ASSESSMENT EXERCISE

### Multiple Choice Question

- Q1. In 'Savdhan' position the angle formed by both the feet at the ankle is \_\_\_\_\_ degree.
- (a) 15 (b) 30  
(c) 45 (d) 60
- Q2. In 'Vishram' position the distance between toes of both feet, \_\_\_\_\_ inches.
- (a) 10 Inch (b) 16 Inch  
(c) 12 Inch (d) 18 Inch
- Q3. In 'Vishram' position the left hand should be straight with \_\_\_\_\_.
- (a) Ground (b) Waist/Kamar  
(c) Shoulder/Kandha (d) Side stitching of trouser
- Q4. In 'Vishram' position the distance between the heels of both feet is \_\_\_\_\_ inches.
- (a) 10 (b) 12  
(c) 16 (d) 18
- Q5. In 'Vishram' position the right hand palm should be \_\_\_\_\_ the left hand palm.
- (a) below (b) under  
(c) above (d) in front of
- Q6. When we are with rifle and talking to our senior, we should be in \_\_\_\_\_ position.
- (a) Savdhan (b) Aram se  
(c) Vishram (d) Bhumi shastra
- Q7. In Arms Drill, during *Savdhan* position, the rifle butt should touch the \_\_\_\_\_.
- (a) Ground (b) Knee  
(c) Toe (d) Waist
- Q8. Rifle Drill is applicable for \_\_\_\_\_ cadets.
- (a) Junior Division/Wing (b) Senior Division/Wing  
(c) All of the above (d) None of the above



- Q9. Rifle Drill is part of \_\_\_\_\_.
- (a) Foot Drill (b) Ceremonial Drill  
(c) Both (a) & (b) (d) None of the above
- Q10. During *Savdhan* position the rifle should be in \_\_\_\_\_ hand.
- (a) Right (b) Left  
(c) Both (d) None of the above
- Q11. Do not move \_\_\_\_\_ during *Savdhan* position.
- (a) Hand (b) Eye ball  
(c) Leg (d) All the above
- Q12. During *Vishram*, rifle should be in \_\_\_\_\_ hand.
- (a) Left (b) Right  
(c) Both (d) None of the above
- Q13. In *Savdhan* position rifle is on the \_\_\_\_\_ side of cadet.
- (a) Left (b) Right  
(c) Any side (d) None of the above
- Q14. In '*Aram se*' position you cannot move \_\_\_\_\_.
- (a) Leg (b) Upper body  
(c) Both (a) & (b) (d) None of the above
- Q15. \_\_\_\_\_ rifle is used during rifle drill in NCC.
- (a) INSAS (b) SLR  
(c) LMG (d) .22 Deluxe

### Short Answer Question

- Q1. What is need for '**Savdhan**' in Rifle Drill?
- Q2. What is the need of **Vishram** in Rifle drill?
- Q3. What are the points to note in **Savdhan** position?
- Q4. What are the points to note in **Vishram** position?
- Q5. What is the difference between **Savdhan** and **Vishram** position?



### Long Answer Question

- Q1. Explain the **Savdhan** drill with rifle?
- Q2. Explain the **Vishram** drill with rifle?
- Q3. How is rifle held in **Savdhan** and **Vishram** position?



## ARMS DRILL (SD/SW)

### CHAPTER AD II: PARADE PAR AND SAJ DRILL WITH RIFLE

“The future depends on what we do in the present”



### TEACHING INSTRUCTIONS

<b>Period</b>	:	One (01)
<b>Type</b>	:	Lecture and Practice.
<b>Year</b>	:	SD/SW: 1 <sup>st</sup> Year – 01 Period
<b>Conducting Officer</b>	:	Permanent Instructor.
<b><u>Training Aids</u></b>	:	Black Board, Chart, Video & DP Rif.

<b><u>Time Plan</u></b>	<b><u>1st Year</u></b>
-------------------------	------------------------

- |   |   |        |
|---|---|--------|
| ➤ General statement and demonstration       | : | 15 Min |
| ➤ Practice of Parade Par and Saj with rifle | : | 25 Min |

## INTRODUCTION

1. Parade **Par** and **Saj** with rifle are important movements in Arms Drill. These are the basic movements to organise a Guard for Guard of Honour or Ceremonial Drill. It is therefore very important to learn these movements in detail.



### PREVIEW

This lesson will be conducted in two parts:-

- Part I : Parade **Par** with rifle.
- Part II : **Saj** with rifle.

### LEARNING OBJECTIVES

- Drill of **parade par** with rifle.
- Drill of **saj** with rifle.

### INTERESTING FACT

- Drill was conceptualized by Major Gen Dral of Germany in 1666.



## PART I: PARADE PAR WITH RIFLE

2. **Need.** When we have to do movement with weapon or before doing **Saj** drill, drill of **Parade Par** is carried out in **Samtol Shastra** position.
3. **Demonstration by Statement and Count (Bayan Aur Ginti se Namuna).** From '**Savdhan**' position when word of command '**Squad Parade Par**' is received then on this word of command lift the rifle up by about 1.5 inch above the ground and shout **Ek**. Point to note in this position is that the rifle is lifted straight about 1 or 1.5 inch above the ground and balance position will be of **Savdhan**. Thereafter the squad speed marches (**Tej Chal**) with rifle held 1-1.5 inch above the ground in the right hand and halts (**Tham**) at the marker with the butt of the rifle on the ground.

**Savdhan Position**



**Speed March in Samtol Shastra**



## PART II: SAJ WITH RIFLE

4. **Need.** When more than one cadet does the drill of '**Parade Par**' with rifle then the word of command of '**Saj**' is given so that all cadets are aligned properly in a straight line.



5. **Statement and Demonstration.** On the word of command '**Saj**', first line of squad extend their left hand to the left, turn their head 90 degree left, get the rifle in **Samtol Shastra** position and move rapidly on their heels to adjust in line with cadet on his left to get the alignment correct.



### CONCLUSION

6. '**Parade Par**' and '**Saj**' procedure are carried out before starting any squad drill. Therefore, it is imperative that all SW/SD cadets are trained in this drill. In this drill, cadets have to learn '**Parade Par**' from '**Savdhan**' position and after reaching the marker they have to do **Saj** drill.

### SUMMARY

- **Parade Par.** Rifle is lifted 1- 1.5 inch above the ground in right hand and balance their position in **Savdhan**. In this position, the cadets reach the marker with speed march.
- **Saj.** First line must extend their left hand to the left, turn their head 90 degrees to the left, move on heel to get the alignment of cadet standing to the left correct.

**ASSESSMENT EXERCISE****Multiple Choice Question**

- Q1. On the order of *Parade Par*, rifle is lifted how much above the ground?
- (a) 1-1.5 Inch (b) 2-3 Inch  
(c) 4-5 Inch (d) 5-6 Inch
- Q2. Word of command *Squad Parade Par* is given from which position?
- (a) Vishram Position (b) Savdhan Position  
(c) Savdhan and Vishram both position (d) None of the above
- Q3. *Saj* drill is carried out to achieve\_\_\_\_\_ .
- (a) Line Tod (b) Parade Par  
(c) Correct alignment (d) Correct Direction
- Q4. *Saj* drill happens on \_\_\_\_\_.
- (a) Toe (b) Heels  
(c) Knee (d) Ankle
- Q5. Rifle is held in\_\_\_\_\_ position during *Saj* drill.
- (a) Bagal Shastra (b) Baju Shastra  
(c) Bhumi Shastra (d) Samtol Shastra
- Q6. Word of command *Squad Saj* is given from \_\_\_\_\_ position.
- (a) Savdhan (b) Baju Shastra  
(c) Bhumi Shastra (d) None of the above
- Q7. Rifle is held in \_\_\_\_\_ position during *Parade Par* drill.
- (a) Bagal Shastra (b) Baju Shastra  
(c) Bhumi Shastra (d) Uthao Shastra
- Q8. During *Saj*, \_\_\_\_\_ hand is extended to the left.
- (a) Right (b) Left  
(c) Both (d) None of the above



- Q9. On the word of command of Parade *Par*, marching is done in \_\_\_\_.
- (a) Tej Chal (b) Dheere Chal  
(c) Aaram Se (d) All of the above
- Q10. During the drill of *Saj* with rifle, head is turned \_\_\_\_ degree left.
- (a) 75 (b) 45  
(c) 90 (d) 120

### **Short Answer Question**

- Q1. What is the need of Parade *Par* drill?
- Q2. What are points to be seen in Parade *Par* drill position?
- Q3. Why the drill of *Saj* with rifle is needed?
- Q4. What points to be noted during *Saj* drill?

### **Long Answer Question**

- Q1. Explain the drill of Parade *Par* with rifle?
- Q2. Explain the drill of *Saj* with rifle?



## ARMS DRILL (SD/SW)

### CHAPTER AD III: VISARJAN AND LINE TOD WITH RIFLE

“Imagination is more important than knowledge”



### TEACHING INSTRUCTIONS

<b>Period</b>	: One (01).
<b>Type</b>	: Lecture and Practice.
<b>Year</b>	: SD/SW: 1 <sup>st</sup> Year – 01 Period.
<b>Conducting Officer</b>	: Permanent Instructor.
<b><u>Training Aids</u></b>	: Black Board, Chart, Video & DP Rif.

<b><u>Time Plan</u></b>	<b><u>1<sup>st</sup> Year</u></b>
➤ General statement and demonstration	: 15 Min.
➤ Practice of Visarjan and Line Tod Drill with Rifle	: 25 Min.

## INTRODUCTION

1. At the end of the Drill, '**Line Tod**' and then '**Visarjan**' drills are carried out. This action is done in the same way as it is done in bare hand drill. However, to further amplify, the subtle difference between **Visarjan** and **Line Tod** is amplified below.
2. **Visarjan**. This command means to 'Dismiss', and is used to officially release soldiers (cadets here) from parade or any formation. Here the individuals are free to break away from the formation. It is a formal dismissal, meaning the individuals are free to leave the parade ground.
3. **Line Tod**. This command means "Break the Line", and is used to allow soldiers (cadets here) to disperse from a specific formation, but not to dismiss them completely. The term **Line Tod** is often used to re-assemble troops in a different formation. That means, the instructions are to break the current formation but remain available for further orders.



### PREVIEW

This lesson will be conducted in one part:-

- Having **Visarjan** and **Line Tod** drill with rifle

### LEARNING OBJECTIVES

- The drill of **visarjan** with rifle.
- The drill of **line tod** with rifle.

## PART I: VISARJAN AND LINE TOD WITH RIFLE

4. **Need**. At the end of the drill, **Visarjan** and then **Line Tod** drills are done.



5. **Demonstration by Statement (Bayan Aur Ginti se Namuna).**

(a) **Visarjan**. When word of command from **Savdhan** position is given, '**Squad/Platoon Visarjan**', then, do '**Bagal Shastra**', turn right, do salute with rifle, take three steps forward and move away.

(b) **Line Tod**. Drill of '**Line Tod**' is same as that of '**Visarjan**'. However, action of Salute (Step-3 above) from '**Bagal Shastra**' is not done in '**Line Tod**' drill.



### **CONCLUSION**

6. On termination of any drill parade, last drill of '**Visarjan**' and '**Line Tod**' is carried out.

### **SUMMARY**

- In the Army, General Salute is applicable to Flag Officer viz Major General and above.
- **Visarjan**. On the word of command '**Visarjan**', do **Dahine Mud**, then **Salute**, thereafter take three steps forward and move away
- **Line Tod**. On the word of command '**Line Tod**', No saluting from '**Bagal Shastra**' will be done

### **INTERESTING FACT**

- Drill was started in India in 1834.



## ASSESSMENT EXERCISE

### Multiple Choice Question

- Q1. During Line Tod with rifle, rifle should be in \_\_\_\_\_ position.
- (a) Bagal shastra (b) Baju shastra  
(c) Salami shastra (d) None of the above
- Q2. During Visarjan with rifle the squad/platoon should move\_\_\_\_\_ side.
- (a) Right (b) Left  
(c) Any side (d) None of the above
- Q3. During Visarjan with rifle the squad/platoon should take \_\_\_\_\_ steps.
- (a) 04 steps (b) 05 steps  
(c) 03 steps (d) 02 steps
- Q4. In which position the word of command Line Tod should be given?
- (a) Vishram (b) Savdhan  
(c) Any position (d) None of the above
- Q5. During Visarjan with rifle salute will be given after \_\_\_\_\_.
- (a) Baju shastra (b) Bagal shastra  
(c) Dahine Mud (d) None of the above
- Q6. During Visarjan /Line Tod, the squad should do \_\_\_\_\_before Dahine Mud.
- (a) Bagal shastra (b) Baju shastra  
(c) Bhumi shastra (d) Jaanch shastra
- Q7. In Visarjan/Line Tod with rifle, when the squad turns right, the rifle should be in \_\_\_\_\_ position.
- (a) Bagal shastra (b) Baju shastra  
(c) Any position (d) None of the above
- Q8. In Visarjan with rifle, salute should be done by \_\_\_\_\_ hand.
- (a) Right (b) Left  
(c) Any hand (d) None of the above



- Q9. In Visarjan/Line tod with rifle, rifle should be carried in the \_\_\_\_\_ hand.
- (a) Right (b) Left  
(c) Any hand (d) Both hands

### Short Answer Question

- Q1. What all points to be kept in mind during **Line Tod** with rifle?
- Q2. What all points to be kept in mind during **Visarjan** with rifle?
- Q3. When should you do **Line Tod** with rifle?
- Q4. At what time should you do **Visarjan**?
- Q5. What is the requirement of **Line Tod** and **Visarjan** in Arms Drill?

### Long Answer Question

- Q1. Explain the drill of **Visarjan** with rifle?
- Q2. Explain the drill of **Line Tod** with rifle?
- Q3. What is the difference between **Line Tod** and **Visarjan** with rifle?

## ARMS DRILL (SD/SW)

### CHAPTER AD IV: BHUMI SHASTRA AND UTHAO SHASTRA

“Only through a right education can a better order of society be built”

#### TEACHING INSTRUCTIONS



<b>Period</b>	:	One (01).
<b>Type</b>	:	Lecture and Practice.
<b>Year</b>	:	SD/SW: 1 <sup>st</sup> Year – 1 Period
<b>Conducting Officer</b>	:	Permanent Instructor.
<b><u>Training Aids</u></b>	:	Black Board, Chart, Video & DP Rif.
<b><u>Time Plan</u></b>		<b><u>1<sup>st</sup> Year</u></b>
➤ Introduction/ Recapitulation (Theory)	:	10 Min
➤ Practice of Bhumi Shastra and Uthao Shastra	:	30 Min



## INTRODUCTION

1. Before starting the drill with the rifle or during the weapon training or while performing the DST procedure, drill of '**Bhumi Shastra**' and '**Uthao Shastra**' is carried out. In this drill, the procedure of placing the rifle on the ground and lifting the rifle is taught.



### PREVIEW

This lesson will be conducted in two part:-

- Part I : **Baju Shastra**
- Part II: **Uthao Shastra**

### LEARNING OBJECTIVES

- The drill of **Bhumi Shastra**.
- The drill of **Uthao Shastra**.

## PART I: BHUMI SHASTRA

2. **Need.** When rifle has to be placed on the ground from '**Savdhan**' position then the drill of '**Bhumi Shastra**' is required to be conducted.

3. **Demonstration by Statement and Count (Bayan Aur Ginti se Namuna).**

(a) When the word of command '**Bhumi Shastra**' is received then lean forward, the upper body still being in '**Savdhan**' position and shout '**Ek**'. Point to note here in this position is that the knees are open, heels are closed, rifle is in right hand, barrel of the rifle is facing forward, magazine is facing outside and the rifle is touching the ground.

- (b) Then leave the rifle on the ground, stand straight in '**Savdhan**' position and shout '**Do**'.

Step-1



Step-2



### INTERESTING FACTS OF DRILL

- In India, drill was started at Ghorpadi, Pune

### PART II: UTHAO SHASTRA

4. **Need.** When rifle has to be lifted from ground in **Savdhan** position then drill of **Uthao Shastra** is carried out.
5. **Demonstration by Statement and Count (Bayan Aur Ginti se Namuna).**
  - (a) When the word of command is received in '**Savdhan**' position '**Uthao Shastra**' then lean forward, the upper body still being in '**Savdhan**' position and shout '**Ek**'. Point to note here in this position is that the knees are open, heels are closed, right hand is in line with right toe while holding the barrel of the rifle and rifle is lifted a little over the ground.



(b) Next step is to pick up the rifle from the ground quickly and stand in '*Savdhan*' position and shout '*Do*'.



Step-1



Step-2



Step-3

### CONCLUSION

6. Often during weapon drill and during DST procedure, drill of '*Bhumi Shastra*' and '*Uthao Shastra*' is carried out. Therefore, it is necessary that cadets pay attention to the details of this drill.

### SUMMARY

- ***Bhumi Shastra***. Knee open and heels connected, rifle in right hand, barrel to the front and magazine facing outside with rifle resting on the ground.
- ***Uthao Shastra***. Knee open and heels connected and right hand in line with right toe and barrel of the rifle to be held in right handle and rifle lifted a little over the ground.



## ASSESSMENT EXERCISE

### Multiple Choice Question

- Q1. Weight of the body in *Bhumi Shastra* position should be on \_\_\_\_\_.
- (a) Left Foot (b) Right Foot  
(c) Both Foot (d) Towards Front
- Q2. In *Bhumi Shastra*, rifle magazine should be facing \_\_\_\_\_.
- (a) Towards outside (b) Towards inside  
(c) Both of above right (d) Both of above wrong
- Q3. In *Bhumi shastra*, the waist should bend at what angle?
- (a) 90 Degree (b) 60 Degree  
(c) 75 Degree (d) 45 Degree
- Q4. *Baju Shastra* word of command is given from \_\_\_\_\_ position .
- (a) Vishram (b) Aaram se  
(c) Savdhan (d) None of the above
- Q5. *Bhumi Shastra* should be done in \_\_\_\_\_ position.
- (a) Savdhan (b) Vishram  
(c) Both position (d) Aram se
- Q6. During *Bhumi Shastra* rifle should be laid down on \_\_\_\_\_
- (a) Ground (b) Hand  
(c) Above shoulder (d) None of the above
- Q7. During *Bhumi shastra* rifle should be held in hand.
- (a) Left (b) Right  
(c) Any hand (d) None of the above
- Q8. During *Uthao Shastra* the right hand should be in the line of toe.
- (a) Right toe (b) Left toe  
(c) Any toe (d) None of the above



- Q9. During *Uthao Shastra* portion of rifle should be held in right hand.
- (a) Barrel (b) Body  
(c) Butt (d) None of the above
- Q10. During *Uthao Shastra* barrel of the rifle should be held by hand.
- (a) Left (b) Right  
(c) Any hand (d) None of the above
- Q11. *Uthao Shastra* word of command is given in position.
- (a) Savdhan (b) Vishram  
(c) Aram se (d) None of the above

### **Short Answer Question**

- Q1. Describe ***Bhumi Shastra***.
- Q2. Describe ***Uthao Shastra***.
- Q3. What is the requirement of ***Bhumi Shastra***?
- Q4. What is the requirement of ***Uthao Shastra***?
- Q5. What all points should keep in mind during ***Uthao Shastra***?

### **Long Answer Question**

- Q1. Explain the difference between ***Bhumi Shastra*** & ***Uthao Shastra***?
- Q2. What are the points to borne in mind while doing ***Bhumi Shastra***?

## ARMS DRILL (SD/SW)

### CHAPTER AD V: BAGAL SHASTRA AND BAJU SHASTRA

“The greatest failure is not to try”



### TEACHING INSTRUCTIONS

<b>Period</b>	: Two (02).
<b>Type</b>	: Lecture and Practice.
<b>Year</b>	: SD/SW - 1 <sup>st</sup> Year - 2 periods
<b>Conducting Officer</b>	: Permanent Instructor.
<b><u>Training Aids</u></b>	: Black Board, Chart, Video & DP Rif.
<b><u>Time Plan</u></b>	<b><u>1<sup>st</sup> Year</u></b>
➤ Introduction/ Recapitulation (Theory)	: 10 Min
➤ Practice of <b><i>Bagal Shastra and Bajou Shastra</i></b>	: 30 Min



## INTRODUCTION

1. If one has to move from one place to other with rifle, then the movement is carried out in **Bagal Shastra** position. Besides this, the Regiment / Unit contingent also does the march past with the rifle in **Bagal Shastra** position. Sentry at the Quarter Guard salutes the rank from Naib Subedar to Captain with the rifle in **Bagal Shastra** position too.

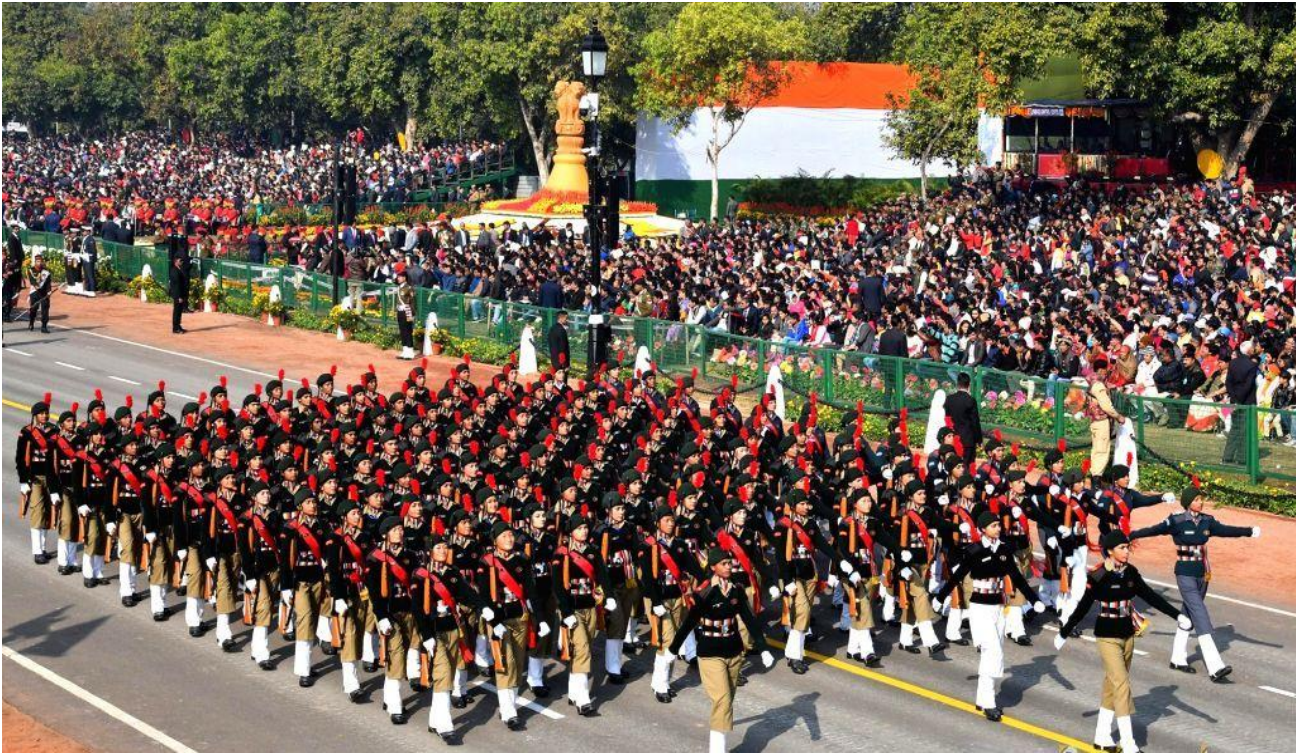

### PREVIEW

This lesson will be conducted in two parts:-

- Part I: Bagal Shastra.
- Part II: Baju Shastra.

### LEARNING OBJECTIVES

- The drill of bagal shastra.
- The drill of baju shastra.

## INTERESTING FACTS OF DRILL

- Drill inculcates the sense of discipline and team spirit.

## PART I: BAGAL SHASTRA

2. **Need.** If one has to move with rifle from one place to another or do march past in a parade, then it is necessary to carry the rifle in **Bagal Shastra** position.

3. **Demonstration by Statement and Count (Bayan Aur Ginti se Namuna).**

(a) From **Savdhan** position, when the word of command is given '**Bagal Shastra**', toss the rifle a little up in the air with the right hand and simultaneously hold pistol grip with right hand while left hand clasps the rifle on forehead guard and shout **Ek**. Point to note in this position is that the left hand from elbow to wrist is in line with the belt, four fingers of left hand gripping the forehead guard from outside while the thumb is held from inside of the forehead guard. Pistol grip is held firmly with right hand and balance position is that of '**Savdhan**'.

(b) When the word of command is received '**Squad Do**' then move the left hand quickly in '**Savdhan**' position and shout **Do**. Point to note in this position is that the rifle is in '**Bagal Shastra**' and balance other position will be of '**Savdhan**'.



**Bagal Shastra**



## PART II: BAJU SHASTRA

4. **Need.** To bring down the rifle from **Bagal Shastra**, drill of **Baju Shastra** is carried out. Also, on termination of any parade, drill of **Baju Shastra** from **Bagal Shastra** is carried out.
5. **Demonstration by Statement and Count (Bayan Aur Ginti se Namuna).**
  - (a) When word of command is given, '**Ginti se Baju Shastra Ek**' then on this word of command grip the barrel below the flash hider and shout **Ek**. Point to note in this position is that barrel is held tightly with left fist, left wrist is touching the chest and balance position is of '**Savdhan**'.
  - (b) When word of command is given '**Squad Do**' then slide the rifle straight down with the left hand, release the pistol grip from right hand and hold the forehand guard from right hand as in **Savdhan** position and shout '**Do**'. Point to note in this position is that flash hider is held by left hand in U-shape, right hands four fingers from outside and thumb from inside is holding the forehand guard, as in '**Savdhan**' position. Rifle is one inch above the ground in line with the right toe.
  - (c) When word of command is given '**Squad Teen**' then bring the left hand down as in '**Savdhan**' position and with the right hand, slide the rifle down so that butt rests on the ground and shout **Teen**. Point to be seen in this position is that final position comes to **Savdhan**.

## CONCLUSION



Step 1



Step 2



Step 3

6. Correct practice of '**Bagal Shastra**' and '**Baju Shastra**' is the basic training of weapon drill. Cadets should learn how to acquire correct position in **Bagal Shastra** and **Baju Shastra**.



## SUMMARY

- **Bagal Shastra**. In two steps rifle is lifted from the ground and brought to the side.
- **Baju Shastra**. In three steps rifle is brought down on the ground from the side.



## ASSESSMENT EXERCISE

### Multiple Choice Question

- Q1. Drill of *Bagal Shastra* is completed in how many steps?  
(a) Three (b) Four  
(c) Two (d) One
- Q2. Drill of *Baju Shastra* is completed in how many steps?  
(a) Three (b) Four  
(c) Two (d) One
- Q3. While marching with rifle during drill, rifle should be in \_\_\_\_\_ position.  
(a) Baju Shastra (b) Bagal Shastra  
(c) Bhumi Shastra (d) Tol Shastra
- Q4. In *Bagal Shastra* position, right hand grips the \_\_\_\_\_ of rifle.  
(a) Forehand Guard (b) Pistol Grip  
(c) Butt (d) Barrel
- Q5. In *Bagal Shastra* position, left hand grips the \_\_\_\_\_ of rifle.  
(a) Forehand Guard (b) Pistol Grip  
(c) Butt (d) None of the above
- Q6. In *Baju Shastra* position, right hand grips the \_\_\_\_\_ of rifle.  
(a) Forehand Guard (b) Pistol Grip  
(c) Butt (d) Barrel
- Q7. In *Baju Shastra* position, left hand grips the \_\_\_\_\_ of rifle.  
(a) Forehand Guard (b) Pistol Grip  
(c) None of the above (d) Any of the above

### Short Answer question

- Q1. What is the need of ***Bagal Shastra***?
- Q2. What is the need of ***Baju Shastra***?
- Q3. What points to be kept in mind while doing ***Bagal Shastra***?
- Q4. What points to be noted while doing ***Baju Shastra***?

### Long Answer Question

- Q1. Explain the drill of ***Bagal Shastra***?
- Q2. Write the drill of ***Baju Shastra***?
- Q3. What is the difference in the drills of ***Bagal Shastra*** and ***Baju Shastra***?

## ARMS DRILL (SD/SW)

### CHAPTER AD VI: SALAMI SHASTRA, BAJU SHASTRA AND CEREMONIAL DRILL

*“There are endless opportunities for those who act selflessly”*



### TEACHING INSTRUCTIONS

<b>Period</b>	:	Six (06 Theory + Practical) + Four (04 Guard Mounting Ceremonial Drill Practical) + Five (05 Guard of Honour Ceremonial Drill Practical)
<b>Type</b>	:	Lecture and Practice.
<b>Year</b>	:	SD/SW: 2 <sup>nd</sup> Year – 03 Periods & 3 <sup>rd</sup> Year – 03 Periods
<b>(Guard (Mounting))</b>	:	2 <sup>nd</sup> Year - 02 Periods & 3 <sup>rd</sup> Year - 02 Periods
<b>(Guard of Honour)</b>	:	2 <sup>nd</sup> Year - 03 Periods & 3 <sup>rd</sup> Year - 02 Periods
<b>Conducting Officer</b>	:	Permanent Instructor
<b><u>Training Aids</u></b>	:	Black Board, Chart, Video & DP Rifle

<b><u>Time Plan</u></b>		<b><u>II<sup>nd</sup> Year</u></b>	<b><u>III<sup>rd</sup> Year</u></b>
Introduction/ Recapitulation (Theory)	:	40 Min	40 Min
➤ Practice of Salami Shastra/ Baju Shastra	:	80 Min	80 Min
➤ Practice of Ceremonial Drill			
○ Guard Mounting	:	80 Min	80 Min
○ Guard Of Honour	:	120 Min	80 Min



## INTRODUCTION

1. In the Indian Armed Forces **Salami Shastra** is a very important element of Rifle Drill. **Salami Shastra** is assigned to extend respect to a senior officer and also in the procedure of Guard of Honour which is a ceremonial welcome to dignitaries. It is of utmost importance that a cadet is well versed and proficient in the procedure of **Salami Shastra** so as to be embodied with a Ceremonial Guard. The concept of the Guard of Honour dates back to ancient military traditions where soldiers formed up in lines to honour their leaders or fallen comrades. Overtime, the Guard of Honour and Ceremonial Guard incorporated procedures which are often performed in detail and with utmost precision.



### PREVIEW

This lesson will be conducted in three parts:-

- Part I: Salami Shastra aur Salami Shastra se Baju Shastra.
- Part II: Ceremonial Drill (Guard of Honour).
- Part III: Ceremonial Guard.

### LEARNING OBJECTIVES

- Be able to do Salami Shastra to a senior officer.
- Be a part of guard of honour formed to honour dignitaries and fallen soldiers.
- Inculcate the basic ethos of Armed Forces.
- Be part of ceremonial parades.
- Achieve purpose of ceremonial guard.

## **PART I: SALAMI SHASTRA AUR SALAMI SHASTRA SE BAJU SHASTRA**

2. **Salami Shashtra Ginti aur Bayan Se Namuna.** While in **Savdhan** and on the word of command '**Ginti se Shashtra Qwaid Salami Shashtra**' the cadet throws the rifle upwards with his/her right hand. The rifle is caught at its forehand guard by the left hand and the right hand clasps the rifle butt. The points to note in this position are:-

- (a) The left hand holds the forehand guard tightly in a manner that the fingers clasp the forehand guard from outwards and the thumb from inwards such that it rests in the hollow of the right shoulder.
- (b) The fingers of the right hand clasps the rifle butt from outwards and the thumb from inwards which are kept pointing towards the ground. The rifle remains close to the body, pointing upwards and the elbow of left hand is pressed back to the rear.
- (c) The body of cadet below the belt remains as it is in **Savdhan** position.

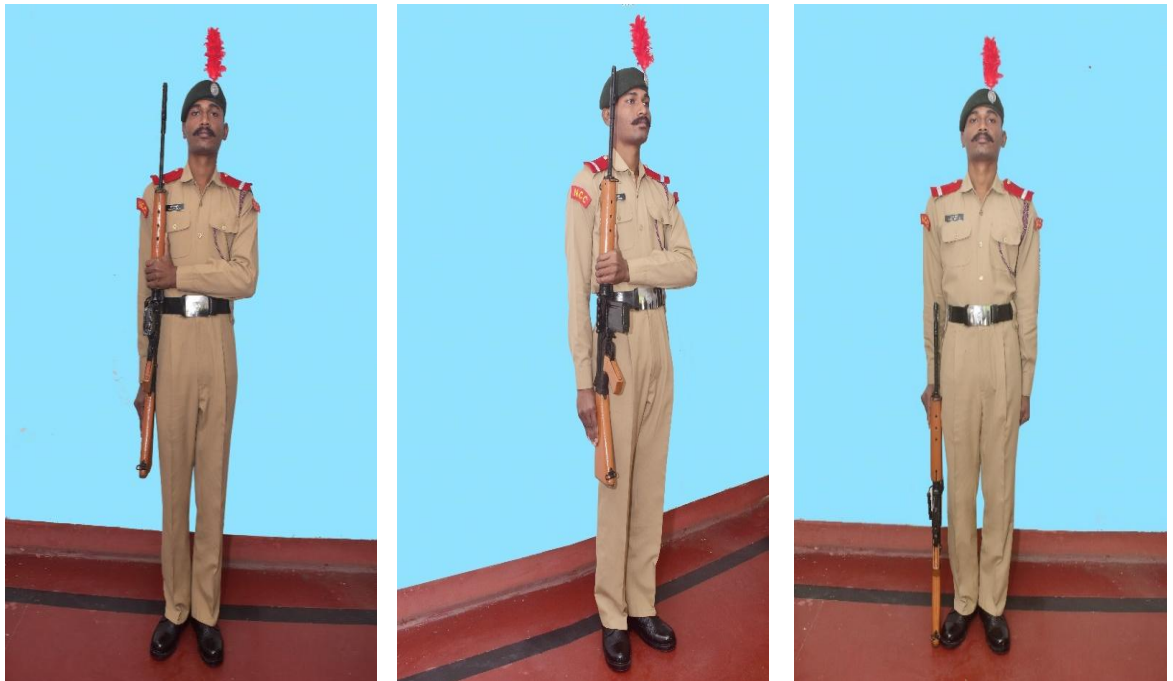

**Position No 1**

3. On the word of command '**Squad Do**' the rifle is brought in front and in centre of the body. In this position the points to note are as follows:-

- (a) The rifle remains upright at 90 degrees with the magazine facing in front.
- (b) The right hand clasps the lower portion of the butt and the left hand strikes the rifle on the left side simultaneously.
- (c) The left hand from its elbow to the wrist touches the rifle.
- (d) The fingers and thumb of left hand are extended and joined. The cocking handle of the rifle is placed between the forefinger and thumb.
- (e) The body of cadet below the belt remains in **Savdhan** position.

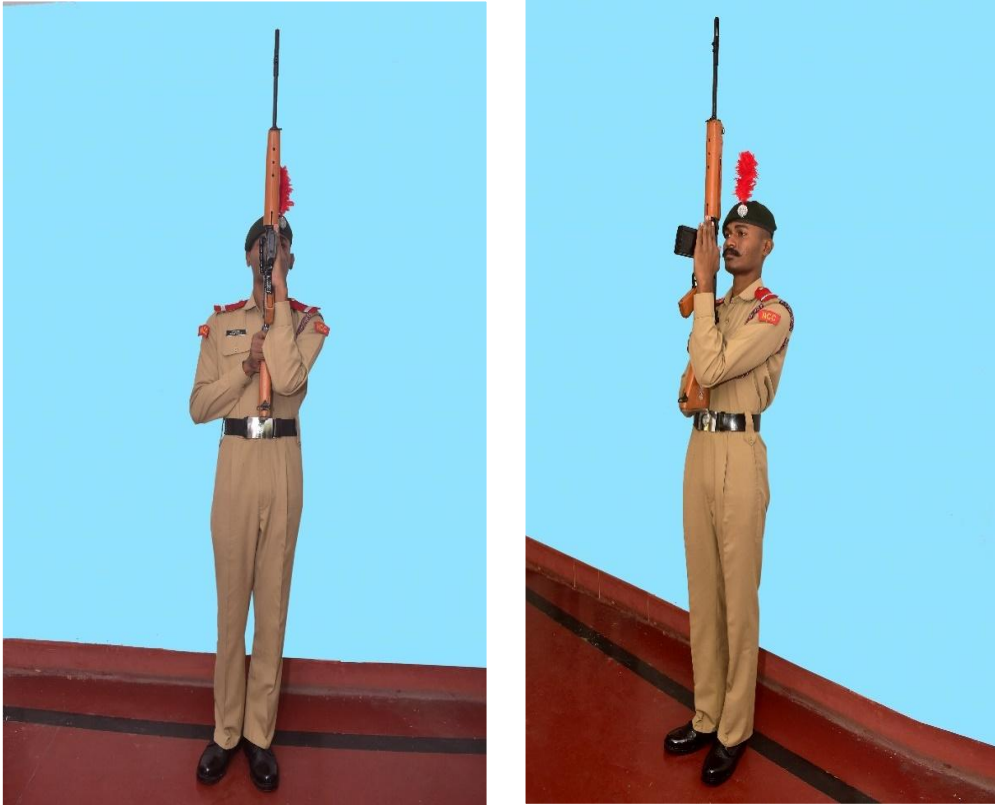

**Position No 2**

4. On the word of command '**Squad Teen**' the rifle is tilted with the left hand and brought down perpendicularly in front, and about three inches from the centre of the body. The rifle is held at the full extent of the right arm and the right foot is placed against the heel of the left foot. The points to note in this position are as follows:-

- (a) The left hand holds the rifle at forehand guard such that the thumb is pointing upwards towards the muzzle and the fingers curl inwards.
- (b) The right hand is extended in front and is holding a small portion of butt immediately below the backsight at the level of waist belt with fingers and thumb slanting downwards.
- (c) Simultaneous to the above actions the right foot is lifted smartly and placed firmly against the left heel ensuring that both knees are straight.
- (d) The weight of the rifle is to be supported by the left hand.
- (e) The barrel is maintained at a distance of six inches from the nose. The rest of the body of cadet remains as it is in **Savdhan** position.

#### **Did you Know?**

When the President of India is not in residence in Rashtrapati Bhavan, the National Flag is not hoisted atop the building. Instead, the flag is lowered and removed. This practice reflects the absence of the President from the official residence



**Position No 3**

### **INTERESTING FACTS OF DRILL**

In January 2015, during Barack Obama's state visit to India, Wing Commander Pooja Thakur became the first woman officer to lead the Guard of Honour Contingent for a foreign leader.

### **Baju Shastra se Salami Shastra**

5. **Need.** After **Salami Shastra** there is a need to come to position of **Baju Shastra** by getting the rifle as in **Savdhan** position.

6. **Ginti aur Bayan se Namuna.** After **Salami Shastra**, on the word of command, '**Ginti se Shastra Qawaid Baju Shastra Ek**', the right hand clasps the forehand guard above the left hand and the right leg is lifted and placed next to the left leg as in **Savdhan** position. The points to note in this position and movement are as follows:-

(a) The rifle remains in the same position as it was in the final position of **Salami Shastra**.

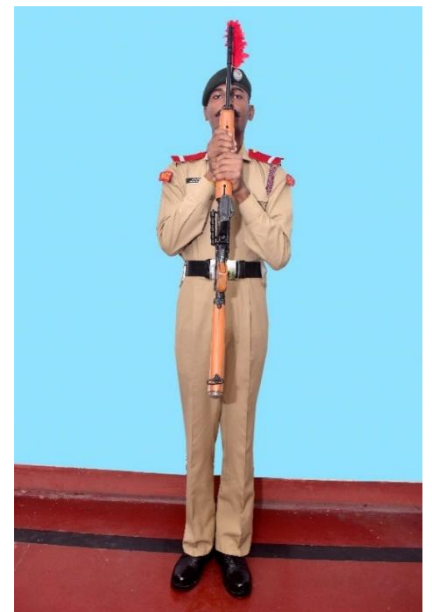

**Position No 1**



- (b) The right hand is placed above the left hand such that the fingers curl inwards and the thumb points upwards towards the muzzle.
- (c) Left hand does not move from its position of third movement of **Salami Shastra**.
- (d) The right leg is lifted very sharply six inches above the ground and is placed with extreme sharpness & firmness next to the left leg with heels touching as in **Savdhan** position.
- (e) The elbows of both the hands are pressed close to the body.
- (f) The rest of the body of cadet remains as is in **Savdhan** position.

7. On the word of command '**Squad Do**' ,move the rifle to the right side with right hand and the left hand releases its grip over the forehead guard. The points to note in this movement and position are:-

- (a) The rifle is moved to right side with the right hand.
- (b) The right hand holds the rifle as in **Savdhan** position.
- (c) The left hand is removed from the forehead guard and holds the flash holder in 'U' shape such that the fingers curl the flash holder from outwards and the thumb from inwards. The rifle is held one inch above the ground with the toe of butt aligned to the toe cap of the boot.
- (d) Simultaneously the palm of left hand is opened and placed touching the barrel along the belt line with fingers and thumb closed.



**Position No 2**

8. On the word of command '**Squad Teen**' the left hand is brought sharply to its position as in **Savdhan** and then simultaneously the rifle is now placed with the butt plate touching the ground as in **Savdhan** position.

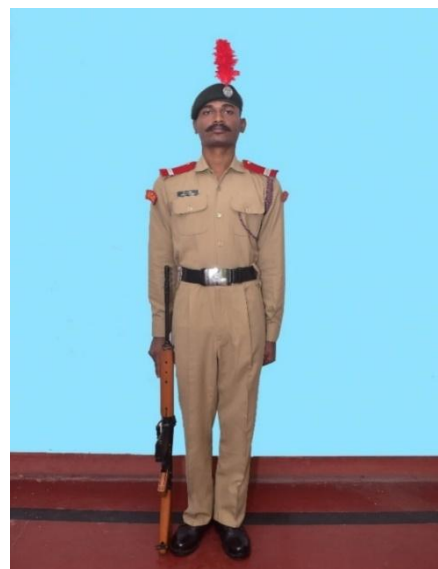

**Position No 3**



## **PART II: CEREMONIAL DRILL (GUARD OF HONOUR)**



### **President's Body Guard (PBG)**

#### **Did you Know?**

The President's Bodyguard (PBG) is the senior-most cavalry unit in the Indian Army, and takes precedence in protocol over all other army regiments and corps. The PBG was established by the then-Governor General Warren Hastings in Varanasi, Uttar Pradesh in the year 1773

9. Drill is an important part of Cadet's life. It inculcates a sense of discipline, improves bearing, smartness in appearance and turn out, creates self-confidence, develops the quality of immediate and implicit obedience to orders and team work. The objectives of Ceremonial Drill are to promote 'esprit de corps' and attain a high standard of steadiness and cohesion on the parade ground to assist in the development of the moral qualities amongst the NCC cadets. These objectives can be attained by careful preparation and exact execution of Ceremonial Drill on all ceremonial occasions. To this end, adequate training and practice will prove to be of utmost importance.

10. The Guard of Honour is given by NCC cadets to the following dignitaries when they visit a NCC camp or on occasions where higher officials have been invited.

- (a) President, Vice President and Prime Minister.
- (b) Governors and Lt Governors.
- (c) Minister of Defence and Minister of State for Defence.



- (d) Chief Minister of the States.
- (e) Chief of Defence Staff.
- (f) Chiefs of Army, Airforce and Navy.
- (g) The Defence Secretary.
- (h) General Officer Commanding- in-Chief of Army Commands
- (j) Flag Officer Commanding-in-chief of Naval Commands .
- (k) Air Officer Commanding- in- Chief of Air Commands .
- (l) Vice Chiefs of Army, Airforce and Navy.
- (m) Director General NCC.
- (n) The Dignitaries addressing the convocation of a University.
- (o) Chancellors of University.
- (p) Pro Chancellor or Vice Chancellor of University as Chief Guest.

### **Layout, Composition and Strength of Guard of Honour**

11. The Guard of Honour will be formed up in three Divisions when all the three services/wings are participating. It will form up in two ranks, with a distance of four paces between the front and rear ranks and will be dressed at a distance of 24 inches. The distance between each Division will be three paces. The layout of Guard of Honour of various strength is given from **appendices A to C**.





12. The position of Cadet Officers will be as under:-

(a) **Guard Commander.** The Guard Commander will be in the centre of the Guard of Honour and eight paces from the front rank.

(b) **Cadets Commanding Division(Army/Airforce/Navy).** The Cadet Commander of the Central Division will be in the centre of his Division and two paces from the front rank. Flank Division commanders will be two paces in front of the second file from the Right and Left of their respective Divisions.

(c) **Right/Left Markers/Guards.** The senior most ranked cadet of the Division/wing concerned (Army/Airforce/Navy) will be the Right guide and the junior ranked cadet will be the Left guide of his/her respective Division.

13. The strength of Guard of Honour for various dignitaries will be as follows.

(a)	President	-	150
(b)	Vice President/Prime Minister	-	100
(c)	Governor/Lt Governor	-	100
(d)	Minister of Defence and Minister of State for Defence	-	50
(e)	Chiefs (of Army, Airforce and Navy), Vice Chiefs (of Army, Airforce and Navy), General Officer Commanding- in-Chief of Army Commands, Flag Officer Commanding-in-Chief of Naval Commands , Air Officer Commanding- in- Chief of Air Commands	-	50
(f)	Head of Foreign State/Governor General of Common Wealth Countries	-	150
(g)	Vice President of Foreign Countries	-	100
(h)	Head of Diplomatic Mission/ Ambassadors and High Commissioner Accredited to India	-	100
(j)	Foreign countries Chief of Armed Forces (Army/Airforce/Navy)	-	50

14. **Types of Salutes.**

(a) **Rashtriya Salute** It will be given only to the President of Republic of India and to Governors, within their own states.

(b) **General Salute.** All senior armed forces officers of the rank Major General or equivalent and above.

(c) **Salami Shastra.** To all other Dignitaries.



15. **Nirikshan (Inspection)**. The procedure of inspection will be as follows:-
- (a) The Guard will be drawn up on the Inspection Line with its centre opposite to the point on dais at which the Dignitary or Inspecting Officer will arrive.
  - (b) At the time of initial arrival of the Dignitary, the Guard will be in **Savdhan**.
  - (c) On arrival of the Dignitary at the dais in front of the centre, the Guard, according to the dignitaries rank/stature, will present the appropriate salute to which the dignitary is entitled.
  - (d) The cadets armed with rifles will do **Salami Shastra** during the salute while cadets without arms will salute.
  - (e) After the appropriate salute to the Dignitary is given, the Guard will be brought to **Baju Shastra**.
  - (f) The Guard Commander will march towards the dais and will give the report- "**Unit Samman Guard Aap ke Nirikshan ke liye Haazir Hai-** Sriman". The Guard Commander salutes and waits for the Dignitary.
  - (g) The Dignitary will now move from the dais towards the Guard, duly escorted by the Guard Commander on his/her left.
  - (h) The moment the Dignitary aligns to the first file of band the Guard Commander positions himself/herself to the right and in line of the Dignitary.
  - (j) Only the President of the Republic of India will be escorted by pilots during the inspection of Guard of Honour.
  - (k) During the inspection, all cadets will look at the Dignitary and turn their heads and eyes to follow the Dignitary while the band will continue to look straight.
  - (l) The band will play until the Dignitary has concluded the inspection. As soon as the inspection is concluded the band stops playing and all the cadets turn their heads sharply to look in front towards the dais. Only the first line will be inspected.
  - (m) After inspection, the Dignitary will be escorted back by the Guard Commander to the dais. The Guard Commander salutes the dignitary and returns to his position.
  - (n) The guard will be rested only after the Dignitary departs and leaves.

#### **DID YOU KNOW?**

- Many well-known personalities of India have been some prominent alumni of NCC. The most famous among them are Dr Rajendra Prasad (first President of India), Netaji Subhas Chandra Bose (University Training Corps - foreshadow of the NCC), Shri Lal Bahadur Shastri (former Prime Minister of India), Shri Narendra Modi, the Prime Minister of India, Shri Rajnath Singh, Defence Minister etc.
- Several senior officers of the Indian Army, Indian Air Force and Indian Navy have were also NCC cadets.



### **INTERESTING FACTS**

Tri-Services Honour Guard is an ad-hoc infantry company of the Indian Armed Forces responsible for providing the Guard of Honour for high-ranking Indian and foreign officials. The company was formed in 1947 soon after India gained its independence from the United Kingdom. The company is made up of 100 men and women, drawn from the three services of the Indian Armed Forces (Indian Army, Indian Navy and Indian Air Force).

### **PART III: CEREMONIAL GUARD (GUARD MOUNTING)**

16. **General.** Ceremonial Guard is mounted to instill in the cadets highest standards of smartness, turnout, bearing and arms drill. The Ceremonial Guard is required to be mounted to extend the befitting required honour and compliments to the distinguished dignitary or a General Officer between Revellie and Retreat.

17. **Procedure by PI Staff for the Guard .** The Guard consists of 2+6 cadets. Besides the six cadets, there is a Cadet Guard Commander and a Cadet Guard 2IC. The layout of which is given at Appendix D. For the Ceremonial Guard the Guard is always made to fall in two ranks with the Cadet Guard Commander being on the far right and the Guard 2IC on the left for the first rank. The detailed procedure to be followed by PI Staff is as under:-

- (a) The PI Staff will march the Guard to the designated place five minutes before the time for Guard mounting.
- (b) The Guard will fall in two ranks, in ***Khuli Line*** and two paces in front of the PI Staff.



- (c) On the word of command '**Guard Parade Par**' the Guard will come to **Savdhan**, march to the designated place, halt at the assigned designated point and turn to face the PI Staff. The Guard will perform **Khuli Line** then do **Baju Shastra** and will come to **Vishram**.
- (d) The PI Staff takes up a suitable position 12 steps in front of the guard and commence inspection procedure.
- (e) On the word of command '**Guard Savdhan**' the Guard comes to **Savdhan** position.
- (f) On the word of command '**Guard Dahine Saj**' the Guard Commander does a Right Turn, marches five steps, halts and then does **Picche Mud**. On orders, the first rank and then the second rank will carry out the procedure of **Saj**. After the **Saj procedure**, PI Staff gives the word of command **Samne Dekh** on which the Guard turn their heads sharply to look in front. The Guard Commander after this assumes his initial position.
- (g) On the word of command '**Guard Bagal Shastra**', the Guard performs **Bagal Shastra**.
- (h) The Orderly Officer is now placed six paces behind the Guard NCO at a suitable position. After this procedure the PI Staff does **Picche Mud** and marches towards the Orderly Officer and halts at a distance of two paces in front of him, salutes and reports **Guard Nirikshan ke Liye Haazir Hai**.
- (j) After the report to the Orderly Officer the Guard NCO does **Picche Mud**, marches and takes up position to the right of the Guard Commander at a distance of six paces from him and does **Samne Mud**.

18. **Procedure by Orderly Officer.** The procedure followed by the Orderly Officer for Guard Inspection is as follows:-

- (a) On the word of command '**Guard Baju Shastra**' the Guard will come to **Savdhan** position and then the Orderly Officer will carryout inspection of the Guard.
- (b) The inspection will be carried out for the first rank followed by inspection of second rank. After inspection, the Orderly Officer will come back to his previous position.
- (c) On the word of command '**Guard Nirikshan Ke Liye Janch Shastra**' the Guard will perform procedure for weapon inspection. The Orderly Officer inspects each weapon starting with the Guard Commander. After the Orderly Officer has examined the weapon of Guard Commander, he accompanies the Orderly Officer for examining weapons of the balance Guard.
- (d) After examining the weapons the Orderly Officer and the Guard Commander move back to their positions.
- (e) On the word of command '**Guard Bolt Chalao**' the Guard releases the bolt slowly.



(f) On the word of command '**Guard Baju Shastra**' the Guard does **Baju Shastra** position and thereafter the Guard Commander orders the Guard to '**Vishram**'.

19. **Procedure on Arrival of Dignitary.** The procedure followed by the Guard for extending the honour and compliments to the Dignitary is as under:-

(a) The moment the Dignitary arrives the Guard Commander comes to **Savdhan** and gives the order '**Guard Savdhan**' at which the Guard comes to **Savdhan** and only the first Cadet Sentry performs **Salami Shastra** to the dignitary ensuring his third motion of **Salami Shastra** is simultaneous to the balance Guard coming to **Savdhan**.

(b) The Guard Commander now gives the order '**Guard Vishram**', at which the entire Guard including cadet sentry comes to the position of **Vishram**. During this the cadet sentry first comes to **Baju Shastra** sharply, and then comes to **Vishram** with the balance Guard.

(c) If the dignitary is entitled to **Salami Shastra** the Guard will now do **Salami Shastra** at which the Dignitary will acknowledge by saluting the Guard.

(d) The Dignitary is escorted in front of the Guard and once the Dignitary is suitably positioned the Guard Commander will first himself come to **Savdhan** and will give the order '**Guard Salami Dega Salami Shashtra**'.

(e) When the Inspecting Officer/Dignitary is taking the salute all accompanying him/her will stand behind in **Savdhan**.

(f) The Guard Commander will now give the word of command '**Guard Baju Shastra**', at which the Guard will come to **Baju Shastra**.

(g) The Guard Commander will alone come to the position of **Bagal Shastra**, present Rifle Salute to the dignitary and report "**Guard Aapke Nirikshan ke Liye Haazir Hai**" after which the Guard Commander comes to **Baju Shastra**.

(h) After receiving the report, in case the Dignitary wishes to inspect the Guard, he/she will go forward to inspect the Guard and commence inspection from the cadet sentry.

(j) After the dignitary has inspected, the Guard Commander he/she will first do **Bagal Shastra** then take a step forward, do **Picche Mud** and accompany the dignitary. The dignitary will first inspect the first rank and thereafter the second rank during which the Guard will remain in **Savdhan**.

(k) When the inspection is concluded the Guard Commander comes back to his/her position and comes to **Baju Shastra** while the dignitary takes his/her position again.

(l) The Guard Commander now comes to **Bagal Shastra**, does Rifle Salute and seeks permission from the Dignitary to do **Visarjan for** the Guard for which permission is sought as "**Shriman, Guard ko Visarjan Karne ki Anumati Chahta/Chahti Hu**".



(m) On receiving the permission, the Guard Commander will come to **Bagal Shastra** and will give the order '**Guard Bagal Shashtra**' at which the Guard will do **Bagal Shastra**.

(n) The Guard Commander will now give the order '**Sentry Khada Rahe, Baaki Guard Visarjan**' at which all the cadets except the rightmost cadet sentry will do **Dahine Mud** and give a 'Rifle Salute'.

(o) The Guard Commander will then do **Bayen Mud** facing the Dignitary while the balance Guard does **Dahine Mud**, takes two steps to their front and then does **Picche Mud** to face the Dignitary.

(p) The Guard Commander now gives the word of command, '**Guard Line Bandh**' at which the first and second rank take two steps in front and aligns to the Guard Commander and the cadet sentry.

(q) The Guard remains at **Bagal Shastra** till the dignitary leaves. Once the dignitary leaves, the Guard Commander gives the word of command '**Guard Line Tor**' at which Guard marches to its resting place.



#### DID YOU KNOW?

The President's Bodyguard is a specialised cavalry regiment of the Indian Army. The primary role of the President's Bodyguard is to escort and protect the President of India.



## CONCLUSION

20. ***Salami Shastra and Salami Shashtra se Baju Shashtra*** are very important lessons in rifle drill which takes a lot of practice to master. Without these actions, a cadet's rifle drill remains incomplete and he cannot be a part of any Ceremonial Drill or even pass his/her Drill Square Test.

21. The Guard of Honour is a special ceremony based on the tradition of Indian Armed Forces in which the President, Governor, Prime Minister, any senior officer and other VIPs are accorded military respect. Guard of Honour and Ceremonial Guard are important ceremonial duties for which a cadet must attain a high degree of proficiency in rifle drill.

## SUMMARY

- ***Salami Shastra*** and ***Salami Shastra se Baju Shastra*** are based on the basic training of rifle drills. Both of these encompass and constitute three movements for successful completion.
- **Salami Shastra.**
- **First Movement.** In this the cadet throws the rifle upwards with his/her right hand. The rifle is caught at its forehand guard by the left hand and the right hand clasps the rifle butt.
- **Second Movement.** In this the rifle is brought in front and in centre of the body with both hands. The right hand is on the small part of the butt, while the left hand is aligned to the rifle.
- **Third Movement.** In this the rifle is tilted with the left hand and brought down perpendicularly in front, and to about three inches from the centre of the body. The rifle is held at the full extent of the right arm while the right foot is placed against the heel of the left foot.
- **Salami Shastra se Baju Shastra.**
- **First Movement.** In this the right hand clasps the forehand guard above the left hand and the right leg is lifted and placed next to the left leg as in ***Savdhan*** position.
- **Second Movement.** In this the rifle is moved to the right side with right hand and the left hand releases its grip over the forehand guard and placed on the flash hider. Simultaneously the palm of left hand is opened and placed touching the barrel along the belt line with fingers and thumb closed.
- **Third Movement.** In this the left hand is brought sharply to its position as in ***Savdhan*** and then simultaneously the rifle is now placed with the butt plate touching the ground as in ***Savdhan*** position.



22. The Guard of Honour is given by NCC cadets to dignitaries when they visit a NCC camp or on occasions where higher officials have been invited. The dignitaries and strength of the Guard of Honour is given under:-

(a)	President	-	150
(b)	Vice President/Prime Minister	-	100
(c)	Governor/Lt Governor	-	100
(d)	Minister of Defence and Minister of State for Defence	-	50
(e)	Chiefs of Army, Airforce and Navy, Vice Chiefs of Army, Airforce and Navy, General Officer Commanding- in-Chief of Army Commands, Flag Officer Commanding-in-chief of Naval Commands (Naval Wing units only), Air Officer Commanding- in- Chief of Air Commands (Air Wing units only)	-	50

23. **Types of Salutes.**

- (a) **Rashtriya Salute.** To the President of Republic of India and to Governors, within their own states.
- (b) **General Salute.** To all senior armed forces officers of the rank Major General or equivalent and above.
- (c) **Salami Shastra** To all other Dignitaries.

24. A Ceremonial Guard is mounted to extend compliments to distinguished persons or a General Officer between Revellie and Retreat.

**DID YOU KNOW?**

The ***Rashtrapati Bhavan*** was known as the Viceroy's House. On 26 January 1950, when Dr. Rajendra Prasad became the first President of India, it was renamed as ***Rashtrapati Bhavan***.



**Appendix 'A'**

**GUARD OF HONOUR (50 RANK & FILE)**

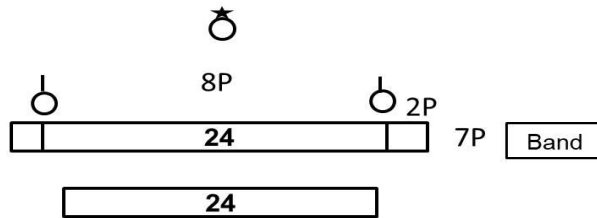
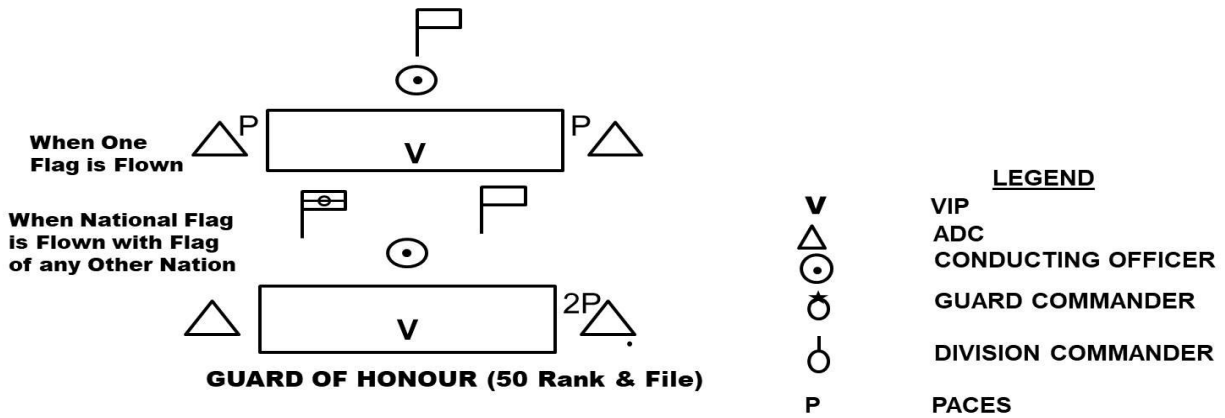

**Appendix 'B'**

**GUARD OF HONOUR 100 RANK & FILE**

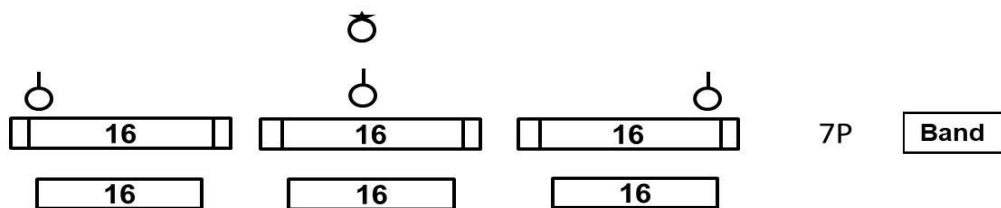
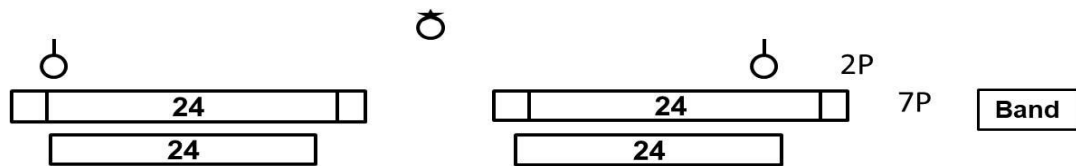
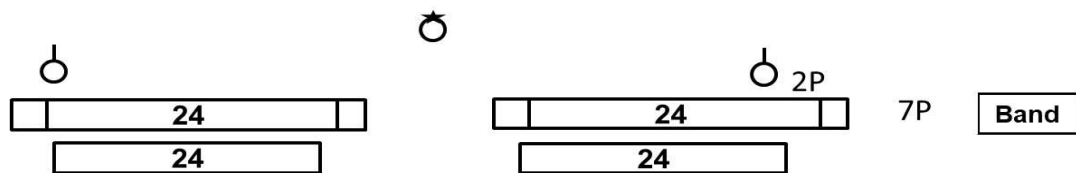



Appendix 'C'

**GUARD OF HONOUR 150 RANK & FILE**

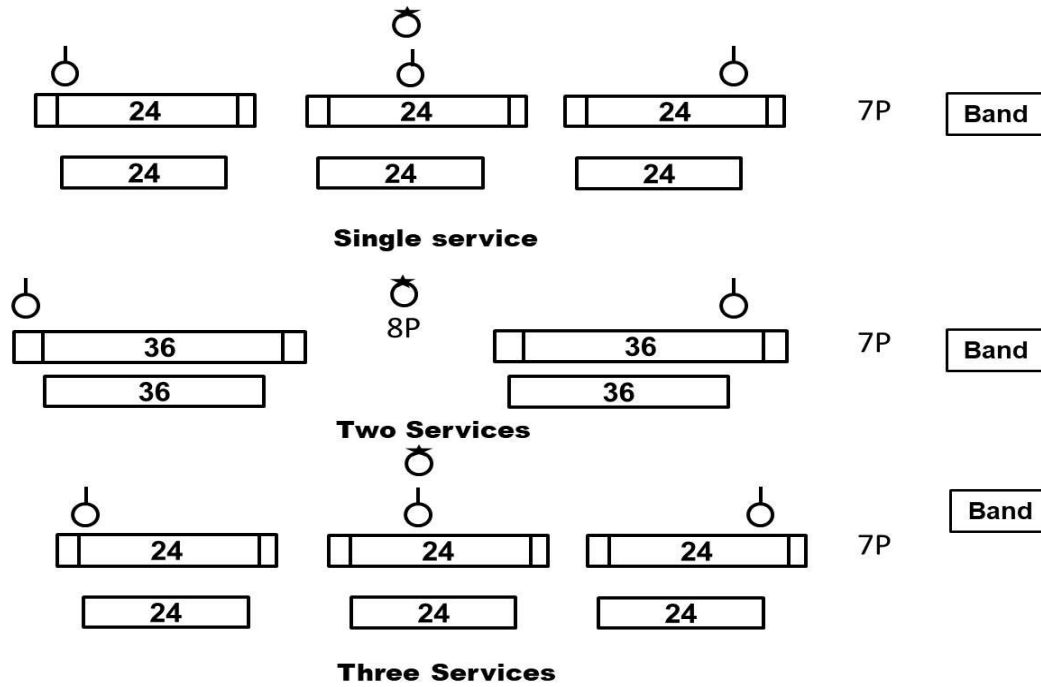

Appendix 'D'

**CEREMONIAL GUARD**

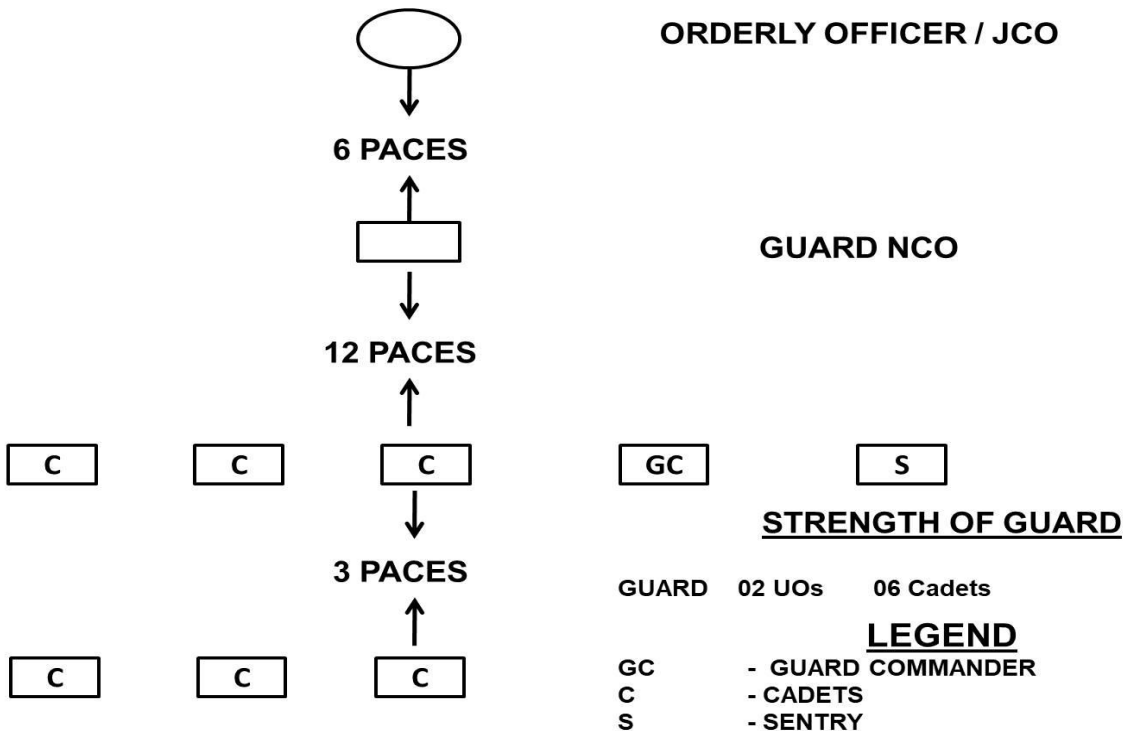



## ASSESSMENT EXERCISE

### Multiple Choice Questions

- Q1. Show many movements are there in Salami Shastra?
- (a) Three (b) Two  
(c) Four (d) One
- Q2. How many movements are there in Bajju Shastra?
- (a) Four (b) Two  
(c) Three (d) One
- Q3. Who among the following are entitled to Salami Shastra?
- (a) Senior Cadet (b) Senior Military Officer  
(c) JCO (d) ANO
- Q4. What is the distance of between the barrel and nose in the third position of Salami Shastra?
- (a) Six Inches (b) Two inches  
(c) Three inches (d) One inch
- Q5. What is the distance between both the ranks during a Guard of Honour?
- (a) Four Paces (b) Three paces  
(c) 10 Paces (d) Six Paces
- Q6. What is the strength of Guard of Honour for the President of India?
- (a) 100 (b) 200  
(c) 150 (d) 50
- Q7. Who amongst the following is entitled to Rashtriya Salute?
- (a) Prime Minister (b) Army Chief  
(c) President (d) Defence Minister
- Q8. During inspection of the Guard of Honour, in reference to the VIP where do the pilots march?
- (a) Infront (b) Right  
(c) Left (d) Behind



- Q9. Guard Mounting is organised in how many files?
- (a) Two Files (b) Three Files  
(c) One File (d) Four Files
- Q10. What is the strength of Ceremonial Guard when done by NCC Cadets?
- (a) 2 x 8 (b) 2 x 6  
(c) 3 x 10 (d) 2 x 5
- Q11. Who issues the word of commands for the Ceremonial Guard Mounting?
- (a) Guard 2 IC (b) Guard Commander  
(c) VIP (d) Bugler
- Q12. What is the strength of Guard of Honour for the Prime Minister of India?
- (a) 100 (b) 200  
(c) 150 (d) 50
- Q13. Who amongst the following is entitled to General Salute?
- (a) Governors within their States (b) Army Chief  
(c) President (d) Colonel
- Q14. At time of arrival of the Dignitary/Inspecting Officer the Guard of Honour is in which position?
- (a) Savdhan (b) Salami Shastra  
(c) Bajju Shastra (d) Vishram
- Q15. During the Inspection of Ceremonial Guard who accompanies the Dignitary?
- (a) No One (b) Cadet Sentry  
(c) Guard Commander (d) Orderly Officer

### **Short Answer Questions**

- Q1. Who are entitled to **Salami Shastra**?
- Q2. In the third position of **Salami Shastra** what is the distance between the rifle barrel and nose of the cadet?
- Q3. Which hand is placed above on the forehead guard in the first motion of **Bajju Shastra**?
- Q4. Describe the motion and position of legs during third movement of **Salami Shastra**?



- Q5. Who all are entitled to a Guard of Honour?
- Q6. State the position of Guard Commander when the Guard is lined up at the inspection line?
- Q7. Which are the different types of salutes given in a Guard of Honour?
- Q8. Which is the seniormost regiment of Indian Armed Forces?
- Q9. Who was the first India to reside in **Rashtarpati Bhavan**?
- Q10. When is Ceremonial Guard organised?
- Q11. Who carries out weapon inspection of a Ceremonial Guard?

### Long Answer Questions

- Q1. In which all instances a cadet is required to do **Salami Shastra**?
- Q2. Explain in detail the third movement of **Salami Shastra**?
- Q3. Explain in detail the entire procedure of **Salami Shastra**?
- Q4. Explain in detail the procedure of **Baju Shastra**?
- Q5. What is the strength of Guard of Honour for various dignitaries?
- Q6. Explain the procedure of inspection of Guard of Honour?
- Q7. Draw and explain the layout of the Guard of Honour for 100 rank and file.
- Q8. Draw the diagram of Ceremonial Guard.
- Q9. Explain the actions of Orderly Officer in the procedure of Ceremonial Guard?
- Q10. Explain the procedure of inspection of guard by the dignitary during Ceremonial Guard.



## FUN FACTS



- The gold-plated, horse-drawn buggy originally belonged to the Viceroy of India during the British period. After the partition of India, both India and Pakistan staked their claim for the buggy. So a unique method was used to resolve this dispute - A toss.
- Colonel Thakur Govind Singh from the Indian side and Sahabzada Yakub Khan from the Pakistani side left the responsibility of the buggy on a coin. The coin went high and can you guess who would have won the toss? Of course, India won.



## ARMS DRILL (SD/SW)

### CHAPTER AD VII: SQUAD DRILL AND DST PROCEDURE WITH RIFLE

“Great things in business are never done by one person. They are done by a team of people”



### TEACHING INSTRUCTIONS

<b>Period</b>	:	Three (03)
<b>Type</b>	:	Lecture and Practice
<b>Year</b>	:	SD/SW - IIIrd Year - 3 Periods
<b>Conducting Officer</b>	:	Permanent Instructor
<b><u>Training Aids</u></b>	:	Black Board, Chart, Video & DP Rif

#### Time Plan

#### IIIrd Year

➤ Introduction/ Recapitulation (Theory)	:	20 Min
➤ Practice of Squad Drill	:	50 Min
➤ Practice of Drill Square Test Procedure	:	50 Min



## INTRODUCTION

1. A squad is a group of soldiers (cadets here) formed for the purpose of instruction, discipline, control and order. Strength of a squad is 9-15 cadets. If a group of 9 -15 cadets have to move from one place to other, then cadets have to form up in the file of three each to make a squad and do the march past smartly. Movement in Squad Drill happens in a group, whereas in Drill Square Test Procedure drill movement of cadet is checked individually. Squad Drill and Drill Square Test Procedure involves multiple drill movements viz *Dahine Mud*, *Bayen Mud*, *Pichhe Mud*, *Tej Chal*, *Bayen aur Dahine Salute*.



### PREVIEW

This lesson will be conducted in two parts: -

- Part I : Squad Drill.
- Part II : DST Procedure.

### LEARNING OBJECTIVES

- To learn about squad drill.
- To learn about DST procedure.

## INTERESTING FACTS OF DRILL

- Drill was first introduced by Romans for its Army to maintain phalanx during war.



## PART I: SQUAD SRILL

### Diagrammatic Layout of a Squad of 15 Cadets.

2. **Squad Layout.** Squad stands in three lines. Gap between left and right cadets and front and back cadets is 2 feet. Squad Commander stands 2 feet forward from center of the front line. (Refer diagrammatic layout above).

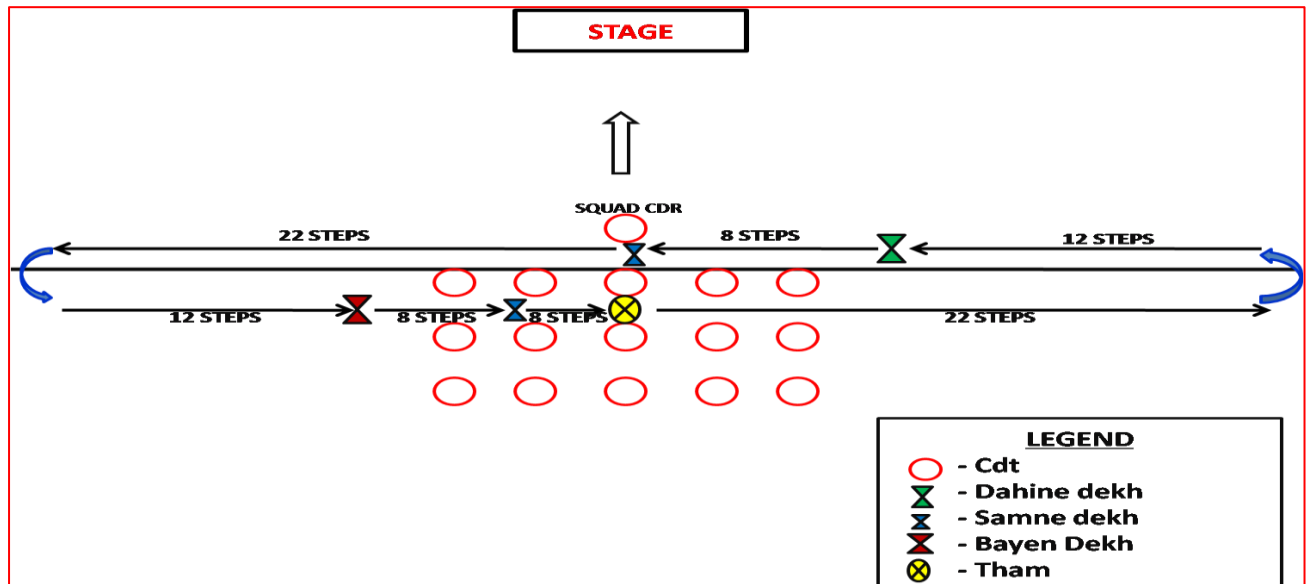

3. **Methods of Squad Drill.** Squad stands in ready condition approximately 10-15 meter away on the left side of the stage. When order is received **Squad Parade Par**, then Squad Commander gives word of command **Squad Teeno Teen Mein Tej Chalega, Tej Chal**. Squad in **Bagal Shastra** position, does march past in **Tej Chal**, reaches in front of the stage and halts when Squad Commander gives the word of command **Tham**. Thereafter, following activities are done:-

- (a) **Step I.** After reaching in front of the stage, Squad Commander gives word of command **Teeno Teen Mein Aage Badhega, Dahine Mud**. On this word of command complete squad will do the drill of **Dahine Mud** whereas Squad Commander himself will do **Bayen Mud** drill to face his Squad.
- (b) **Step II.** After the drill of **Dahine/Bayen Mud**, Squad Commander himself does the drill of **Pichhe Mud** now and salutes the Inspecting Officer with rifle and gives the report – **“Jai hind Shriman, Squad Drill Shuru Karne Ki Anumati Chahta Hun”**. After giving the report, Squad Commander does the drill of **Pichhe Mud** and faces his squad.
- (c) **Step III.** After this, the Squad Commander gives word of command **“Detail, Baju Shastra”**. Then, Squad Commander gives the next word of command **“Detail Khuli Line Chal”**. Squad follows the word of command and does the drill as per the command.
- (d) **Step IV.** Next word of command by the Squad Commander would be **“Detail Saj, Bayen Saj”**. On this word of command, all three cadets of left most file will keep standing while the balance cadets will extend their left hand to the left with fist closed, turn their head 90 degree left and move swiftly on their heels to align themselves with the cadets standing to their left.



(e) **Step V.** Squad Commander ensures that cadets in his squad are aligned in straight lines and does the drill of **Piche Mud** for himself. Thereafter, Squad Commander marches three steps towards the Inspecting Officer, salutes with his rifle and gives the report “**Shriman, Squad Aapke Nirikshan Ke Liye Haazir Hai**”. After giving the report, Squad Commander salutes the Inspecting Officer again, does the drill of **Pichhe Mud**, moves three steps and does **Pichhe Mud** again to face the stage.

(f) **Step VI - Standing Drill.** After the Squad has been inspected Squad Commander himself does **Pichhe Mud** drill to face his squad and gives the word of command “**Detail Nikat Line Chal**”. On this command, squad does the drill of **Nikat Line Chal**. Next word of command given is “**Detail Bagal Shastra**”. On this command, squad does the drill of **Bagal Shastra**. Next word of command given is “**Detail Dahine Chalega, Dahine Mud**”. On this command, squad does the drill of **Dahine Mud** wherein the Squad Cdr remains standing in **Bagal Shastra** position. Next word of command given is “**Detail Aage Badhega, Bayen Mud**”. On this command, squad does the drill of **Bayen Mud** wherein the Squad Cdr remains standing in **Bagal Shastra** position. Next word of command given is “**Detail Bayen Chalega, Bayen Mud**”. On this command, squad does the drill of **Bayen Mud** again wherein the Squad Cdr remains standing in **Bagal Shastra** position. Next word of command given is “**Detail Dayen Se Dahine Mud**”. On this command, squad does the drill of **Dahine Mud** wherein the Squad Cdr remains standing in **Bagal Shastra** position. Next word of command given is “**Detail Pichhe Badega, Pichhe Mud**”. On this command, squad does the drill of **Pichhe Mud** wherein the Squad Commander remains standing in **Bagal Shastra** position. Once again word of command is given - “**Detail Aage Badhega, Pichhe Mud**”. Squad does the drill of **Pichhe Mud** again wherein the Squad Cdr remains standing in **Bagal Shastra** position.

(g) **Step VII.** After the standing drill mentioned above in Step-VI, Squad Commander himself does **Pichhe Mud**, takes three steps towards the stage, salutes the Inspecting Officer with rifle and gives report “**Jai Hind Shriman, XXXX NCC Battalion Squad Ko Kooch Karane Ki Anumati Chahta Hu**”. Squad Commander salutes again and does **Pichhe Mud**, takes three steps towards the squad and does **Tham** facing the squad.

(h) **Step VIII - Drill with Tej Chhaal.** Now the Squad Commander gives word of command “**Detail Dahine Chalega, Dahine Mud**”. On this command, squad does the drill of **Dahine Mud** and the Squad Commander himself does the drill of **Bayen Mud**. With this, Squad Commander and the squad both face in the same direction. Next word of command is given “**Teeno Teen Mein Bayen Se Tej Chal**”. On this command, squad marches 22 steps with **Tej Chal** and then next word of command is given by the Squad Commander **Detail Pichhe Mud**. On this command squad does the drill of **Pichhe Mud** and continues to march with **Tej Chal**. After 12 steps, next word of command is given “**Detail Dahine Dekh**”. On this command Squad Commander does **Dahine Salute** with rifle. First line keeps looking straight and continues to march whereas second and third line turn their head right and continues to march. After 8 steps, next word of command is given “**Detail Samne Dekh**”. On this command, Squad Commander salutes down and second and third line look straight and continues to march. After next 22 steps, word of command is given “**Detail Pichhe Mud**”. On this command, squad does the drill of **Pichhe Mud** and continues to march with **Tej Chal**. Again, after 12 steps, Squad Commander gives word of command “**Detail Bayen Dekh**”. On this word of command, Squad Cdr does **Bayen Salute**, first line while looking straight and second and third line look left and continues to march 8 steps with **Tej Chal**. After 8 steps, word of command is given “**Detail Samne Dekh**”.



On this command, salute down and all three lines look straight and continue to march another 8 steps with **Tej Chal**. Then, on the word of command of '**Tham**', the squad halts.

(j) **Step IX**. Lastly, on the order of "**Squad Visarjan**" everyone does the drill of **Visarjan** and the squad drill ends here.

## PART II: DRILL SQUARE TEST (DST) PROCEDURE

4. **Need**. After the completion of drill training, cadets have to undergo Drill Square Test to find out the level of efficiency acquired by the cadets in drill.

### 5. Diagrammatic Layout of DST Procedure

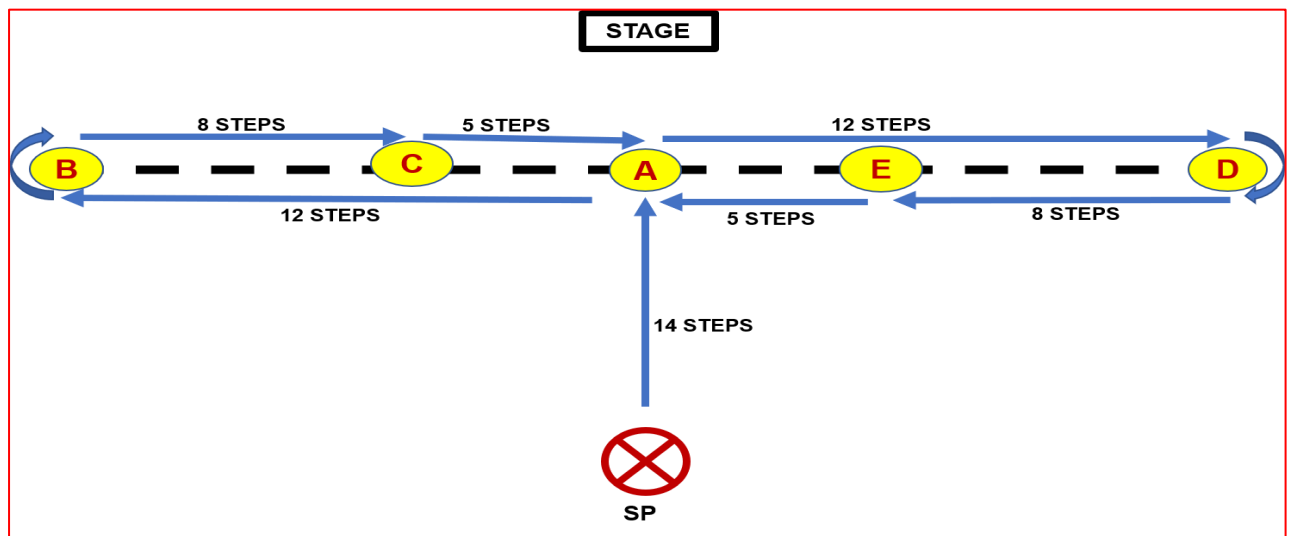

### 6. Demonstration with Statement

- (a) Get in **Savdhan** position with rifle.
- (b) On the order of **Shuru Karo** get the rifle in **Baju Shastra** position. March 14 x steps with **Tej Chal** and do **Tham**.
- (c) **Salute** with rifle and give report to the instructor. **No**\_\_\_\_\_ **Cdt**\_\_\_\_\_ **DST Ke Liye Hazir Hai Shriman**.
- (d) Do two times **Dahine Mud**, one-time **Pichhe Mud**, two times **Bayen Mud** and again one-time **Pichhe Mud**.
- (e) Then do the drills of **Khuli Line** and **Nikat Line Chal**.
- (f) Do 12 Steps of **Tej Chal** and **Pichhe Mud**; and after 8 x Steps do **Bayen Salute** with **Tej Chal**. Salute down after 5 steps.



- (g) Continue with **Tej Chal** and after 12 steps do the drill of **Pichhe Mud**. Again after 8 steps do **Dahine Salute** with rifle and salute down after 5 steps with **Tej Chal**.
- (h) Continue with **Tej Chal** and after 4 steps do **Tham**. Do **Bayen Mud** followed by **Line Tod**.

## CONCLUSION

7. The aim of Drill in NCC is to produce a cadet who is alert and obedient and to provide the basis of teamwork.
8. In Squad Drill and DST Procedure, all actions of rifle drill are included. Therefore, it is necessary that cadets practice all rifle drills properly.
9. Squad Drill improves the morale by developing team spirit.
10. It gives young cadets the confidence of command and the experience in giving proper commands.
11. Squad Drill and DST promotes discipline, alertness, precision, pride, steadiness and the cohesion necessary for any success.

## SUMMARY

- **Squad Drill.** The following sequence is to be kept in mind by each cadet for the Squad Drill - *Parade Par, Tham, Dahine Mud, Baju Shastra, Khuli Line Chal, Bayen Saj, Inspection ki Report, Nikat Line Chal, Bagal Shastra, Dahine Mud, Bayen Mud, Bayen Mud, Dahine Mud, Pichhe Mud, Pichhe Mud, Kooch Karane Ki Report, Dahine Mud, 22 x steps Tej Chal, Pichhe Mud, 12 x steps Tej Chal, Dahine Dekh, 8 x steps Tej Chal, Samne Dekh, 22 x steps Tej Chal, Pichhe Mud, 12 x Tej Chal, Bayen Dekh, 8 x steps Tej Chal, Samne Dekh, 8 x steps Tej Chal, Tham Aur Visarjan.*
- **DST.** Cadets have to be thorough about the DST procedure. *14 steps Tej Chal, Halt, Salute, Report. 2 x Dahine Mud, Pichhe Mud, 2 x Bayen Mud and Pichhe Mud. Khuli Line Chal, Nikat Line Chal and Bayen Mud. 12 x steps Tej Chal, Pichhe Mud, 8 x steps Tej Chal, Dahine Salute, 5 x steps Tej Chal, Salute Down. 12 x steps Tej Chal, Pichhe Mud, 8 x steps Tej Chal, Dahine Salute, 5 x steps Tej Chal, Salute Down. 4 x steps Tej Chal, Tham, Bayen Mud and Line Tod.*



## ASSESSMENT EXERCISE

### Multiple Choice Question

- Q1. In DST, from the start point after \_\_\_\_\_ steps *Tej Chal*, drill of *Tham* is done and report is given.
- (a) 12 (b) 14  
(c) 16 (d) 18
- Q2. DST procedure is conducted in \_\_\_\_\_ method.
- (a) *Tej Chal* (b) *Dheere Chal*  
(c) Both (d) None of the above
- Q3. In DST procedure, Salute is given \_\_\_\_\_ times.
- (a) 6 (b) 5  
(c) 3 (d) 4
- Q4. In DST procedure, \_\_\_\_\_ times drill of *Pichhe Mud* is carried out.
- (a) 6 (b) 5  
(c) 3 (d) 4
- Q5. In DST procedure, \_\_\_\_\_ times *Bayen Mud* drill is done.
- (a) 6 (b) 5  
(c) 3 (d) 4
- Q6. Squad is necessarily formed when the strength of cadets is more than \_\_\_\_\_.
- (a) 3 (b) 5  
(c) 6 (d) 8
- Q7. Squad drill is done in \_\_\_\_\_.
- (a) Empty handed (b) With rifle  
(c) Both (d) None of the above
- Q8. In a Squad, \_\_\_\_\_ feet gap from left and right cadet is maintained.
- (a) 4 feet (b) 8 feet  
(c) 3 feet (d) 2 feet



### **Short Answer Question**

- Q1. What is the need of DST procedure?
- Q2. Write down the drill of ***Nikat Line Chal***.
- Q3. Write the drill of ***Khuli Line Chal***.
- Q4. How is report given during DST procedure?
- Q5. In Squad Drill, how is report given to Inspecting Officer?

### **Long Answer Question**

- Q1. Explain the procedure of DST.
- Q2. Explain the Squad drill in brief.



# WEAPON TRAINING

3



## **CHAPTER WISE INDEX - WT (SD/SW)**

<b>Ser No</b>	<b>Subject</b>	<b>Page</b>
1.	Chapter I : Introduction of Point 22 Rifle	127
2.	Chapter II : Handling of Point 22 Rifle	135
3.	Chapter III : Firing Operation of Rifle	149
4.	Chapter IV : Theory of Grouping and Shot Group Analysis	160
5.	Chapter V : Range Procedure and Security of Range	169
6.	Chapter VI : Short Range Firing	181



## WEAPON TRAINING (SD/SW)

### CHAPTER WT I : INTRODUCTION OF POINT 22 RIFLE

**“Amateurs train until they get it right, professionals train until they can’t get it wrong”**



### TEACHING INSTRUCTIONS

<b>Period</b>	:	One (01)
<b>Type</b>	:	Lecture cum Practice
<b>Year</b>	:	1st Year
<b>Conducting Officer</b>	:	Permanent Instructor.

**Training Aids** : Class Room, Open Training area or Ground, Script or Book Flagged or Lesson Plan in File, Board and Markers, .22 Rifles all types (01 each).

#### **Time Plan**

• Introduction	:	05 Min
• Specifications of .22 Rifle (All Types)	:	15 Min
• .22 Ammunition & Types	:	15 Min
• Conclusion	:	05 Min



## INTRODUCTION

1. Hunting as a means of survival has been man's basic instinct from time immemorial. Earlier men used various types of weapons to hunt, starting gradually with bows and arrows to modern day weapons. In modern world, shooting is an exciting sport and shooting at the ranges not only helps an individual to master this sport but also gain confidence in himself. The fine art of shooting, teaches a person precision, accuracy, co-ordination of body movements, patience and confidence, all of which accrue good results in public life too with a better personality. For an NCC Cadet, introduction to weapon kindles his interest towards firing as a sport and also motivates the individual to join the Armed Forces. Hence a basic understanding of weapons is essential for Cadets.

### PREVIEW

The lecture will be conducted in the following parts:-

- Part I : Introduction.
- Part II : Types of Ammunition.

### LEARNING OBJECTIVES

- Basic understanding of the point 22 rifle.
- Specifications of the different types of point 22 rifles used in NCC for training.
- Visual handling of the weapon.
- Understanding about the ammunition and its types.

### INTERESTING FACTS

- Popular Caliber: The Point 22 Long Rifle (LR).
- Dates back to the late 19th century.
- Point 22 LR was introduced in 1887 by the Stevens Arms Company.
- Used in training due to their manageable recoil and cost effectiveness, making them ideal for learning marksmanship.
- Popular Sporting Weapon

## PART I : FAMILIARISATION OF POINT 22 RIFLE

2. The Point 22 Rifle (also depicted as .22 Rifle) is a light weight and an uncomplicated weapon. Because of its simple design and virtually no recoil, this weapon is used by NCC for firing. Like any other firearm, it is important that before using the weapon, the basic information of this weapon is available to the users.



3. **Specifications of the Point 22 Rifle.**

<b><u>Details</u></b>	<b><u>Rifle Point 22" No II MK IV BA</u></b>	<b><u>Rifle Point 22" Deluxe BA</u></b>	<b><u>Rifle Point 22" Sporting BA</u></b>
<b>Length</b>	45 inches	43 inches	43 inches
<b>Weight</b>	3.93 Kg	2.78 Kg	3 kg
<b>Magazine Capacity</b>	10 Rounds	05 Rounds	10 Rounds
<b>Muzzle Velocity</b>	2700 feet per second	2700 feet per second	2700 feet per second
<b>Grooves in the barrel</b>	06	06	06
<b>Effective Range</b>	25 yards (23 meters)	25 yards (23 meters)	25 yds (23 meters)
<b>Max Range</b>	1700 yds at 33 <sup>0</sup> angle (1550 meters)	1700 yds at 33 <sup>0</sup> angle (1550 meters)	219 yards (200 meters)
<b>Caliber</b>	Point 22"	Point 22"	Point 22"
<b>Ammunition</b>	Point 22"	Point 22"	Point 22"
<b><u>RATE OF FIRE</u></b>			
<b>Normal</b>	05 rounds per minute	05 rounds per minute	05 rounds per minute
<b>Rapid</b>	<b>10-15 rounds/minute</b>	<b>10-15 rounds/minute</b>	<b>10-15 rounds/minute</b>

4. **Types of .22 Rifles Used in NCC.** Presently, three types of .22 Rifles are in use in the NCC.

(a) **Rif .22 No II Mk IV BA**



(b) **Rif .22 mm Deluxe BA**





(c) **Rif .22 Sporting BA**



5. **Parts of a .22 Rifle.** Parts of a .22 Rifle are shown below.



**DESCRIPTION OF PARTS : POINT 22 RIFLE**

1. **Sight.** Device used for aiming usually by aligning a front and rear sight.
2. **Muzzle.** The end of the barrel through which the projectile(bullet or shot) exits.
3. **Barrel.** Metal tube through which the projectile travels.
4. **Forestock.** Front portion of the stock extending under the barrel in front of the receiver, usually held by the non-trigger hand to help support the firearm.



5. **Magazine**. Container on a repeating firearm that holds ammunition before it's loaded into the chamber, usually tubes or boxes attached to the receiver.
6. **Trigger**. Small lever that is squeezed to start the firing process.
7. **Trigger Guard**. Piece that surrounds the trigger to protect it from being squeezed or bumped accidentally.
8. **Butt**. The part of the stock you hold against your shoulder.
9. **Stock**. Handle of Firearm.
10. **Safety**. Mechanical device that blocks the trigger or hammer to prevent accidental firing.
11. **Bolt Handle**. Handle used to open a bolt action.
12. **Bolt**. Moveable metal block that seals a cartridge into the chamber on some actions.
13. **Chamber**. Base of the barrel used to hold the cartridge or shoft shell ready for shooting.

## **PART II : TYPES OF AMMUNITION**

### 6. **Point 22 Ammunition.**

(a) The term .22 refers to the diameter of the bullet, which is approximately 0.22 inches (5.6mm). This measurement defines the caliber of the ammunition and corresponds to the size of the barrel through which it is fired.

(b) Ammunition design has evolved over time as weapon designs have become more refined. Starting with the gunpowder in the 13<sup>th</sup> century, the first cartridge made of paper, were developed in the 1500's which was later replaced by brass. Ammunition consists of a cartridge case which has a propellant and a bullet. As the propellant burns, the bullet is pushed with extreme force towards the target (will be explained in detail in further chapters). The bullets earlier were round lead balls. By the 19<sup>th</sup> century, bullets developed for rifled barrels became more aerodynamic and accurate. The .22 ammunition was first developed in 1857 in the USA.

<b><u>POINT 22 AMMUNITION SPECIFICATIONS</u></b>	
Caliber	Point 22 inch
Length of Bullet	10 mm
Length of Bullet with Case	15 mm
Weight	38/40 gm
Type of Bullet	Lead / Copper
Type of Ammunition	Rim / Rimless



## DIAGRAMMATIC REPRESENTATION OF RIMLESS AND RIMMED AMMUNITION

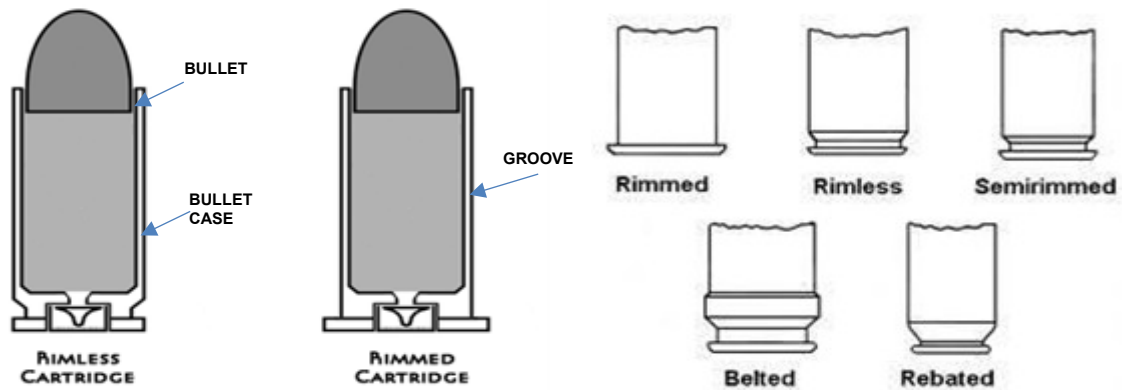

### 7. Difference Between Rimless and Rimmed Ammunition.

- (a) Rimmed cartridges have a rim which helps in extraction by the extractor. It engages the rim at the base of the shell which is significantly wider than the body of the cartridge.
- (b) A rimless cartridge has a groove (as shown in the pic above) just above the end of the cartridge for the extractor to help in extracting. The bottom of the cartridge has the same diameter or are a little smaller (rebated) than the main body.

## CONCLUSION

8. The Point 22 rifle is a highly effective and a reliable weapon. Easy to assimilate, it is the ideal weapon to start training with.
9. Cadets can achieve remarkable firing skills with good knowledge and handling of this weapon.
10. Keen students under an able instructor will have a lot to gain from this chapter.
11. Knowledge of the weapon would lead the Cadets to learn the 'BASICS' properly and thereafter gradually with more practice turn into a Marksman.

## SUMMARY

- The Rifle .22 No II Mk IV BA and .22 Deluxe BA are used in NCC training.
- Both have following characteristics:
  - Caliber .22-inch LR.
  - Muzzle Velocity- 2700 feet per second. Groove: 6 Nos.
  - Effective Range- 25 yards (23 mtrs).
  - Safety : On rear end top of the body by pushing the lever forward
- Both rifles differ in their length, weight, and magazine capacity.
- These weapons fire both .22 Rimmed and Rimless ammunition.



## ASSESSMENT EXERCISE

### Multiple Choice Questions

- Q1. Length of .22 Rifle Mk-IV BA is
- (a) 45 Inch (b) 43 Inch  
(c) 14 Inch (d) 25 Inch
- Q2. Which is not a part of .22 Rif?
- (a) Bore (b) Recoil Spring  
(c) Bolt (d) Piston
- Q3. Effective range of .22 Rifle is \_\_\_\_\_.
- (a) 50 Yds (b) 25 Yds  
(c) 11 Yds (d) 23 Yds
- Q4. Muzzle velocity of 0.22 rifle is \_\_\_\_\_.
- (a) 2400 feet/ second (b) 1100 feet/second  
(c) 2700 feet/ second (d) 2300 feet/ second
- Q5. Magazine capacity of .22 Deluxe rifle magazine is \_\_\_\_\_.
- (a) 05 Rounds (b) 10 Rounds  
(c) 15 Rounds (d) 20 Rounds
- Q6. Weight of .22 Deluxe Rifle \_\_\_\_\_.
- (a) 3.6 Kg (b) 3.69 Kg  
(c) 2.78 Kg (d) 3.68 Kg
- Q7. How many types of ammunition are fired using the .22 Rif?
- (a) 2 (b) 4  
(c) 1 (d) 6
- Q8. .22 Rifle was invented by which country?
- (a) Russia (b) Israel  
(c) India (d) USA
- Q9. Normal rate of fire of .22 Deluxe is \_\_\_\_\_.
- (a) 3 rounds per minute (b) 5 rounds per minute  
(c) 10 rounds per minute (d) 12 rounds per minute



- Q10. A primary weapon of a soldier is \_\_\_\_\_.
- (a) Rifle (b) Pistol  
(c) LMG (d) Mortar
- Q11. .22 Rifle Mk-IV BA and Deluxe differ in \_\_\_\_\_.
- (a) Length (b) Caliber  
(c) Muzzle Velocity (d) Rate of Fire
- Q12. Length of Bullet in .22 ammunition is \_\_\_\_\_.
- (a) 05 mm (b) 10 mm  
(c) 15 mm (d) 20 mm
- Q13. Length of Bullet with case in .22 ammunition is \_\_\_\_\_.
- (a) 05 mm (b) 10 mm  
(c) 15 mm (d) 20 mm
- Q14. Weight of .22 ammunition is \_\_\_\_\_.
- (a) 30/32 gms (b) 35/37 gms  
(c) 38/40 gms (d) 45/47 gms



## WEAPON TRAINING (JD/JW)

### CHAPTER WT II : HANDLING OF POINT 22 RIFLE

*“It is not the weapon that kills, but the hand and the mind that holds it.”*

*- Napoleon Bonaparte*



### TEACHING INSTRUCTIONS

<b>Period</b>	:	Three (03)
<b>Type</b>	:	Lecture cum Demo/ Practice
<b>Year</b>	:	1st Year - 02, 2nd Year - 01
<b>Conducting Officer</b>	:	Permanent Instructor.

**Training Aids:** Open Training area or Ground, Lesson Plan in File, Board and Markers, .22 Rifles for Squad Post Training.

<u>Time Plan</u>		<u>Ist Year</u>	<u>IInd Year</u>
• Introduction	:	05 Min	05 Min
• Handling of .22 Rifle	:	25 Min	10 Min
• Striping & Assembly	:	25 Min	10 Min
• Firing Positions	:	20 Min	10 Min
• Conclusion	:	05 Min	05 Min



## INTRODUCTION

1. A good firer is the one, who can quickly load the magazine into Rifle, aim and fire it effectively. This can only be possible when the firer has learnt the correct procedures and carried out extensive practice during training. It is therefore important that a Cadet with practice is capable of handling the weapon in different firing positions. He should also be aware of the various parts of a Rifle and should know how to strip and assemble it. The more a Cadet dwells on these aspects, the better he or she will be in handling, and effectively using the weapon during firing practices.



### PREVIEW

The lecture will be conducted in the following parts:-

- Part I : Handling of .22 Rifle (Loading, Unloading, Aiming & Trigger Operation).
- Part II : Assembling & Stripping.

### LEARNING OBJECTIVES

- Basic handling of the .22 rifle
- Loading & firing
- Aiming & trigger operation
- Stripping and assembling
- Firing positions

### INTERESTING FACTS

Shooting with both eyes open many shooters are taught to shoot with one eye closed for better focus. However, advanced shooters often keep both eyes open, which provides better peripheral vision and situational awareness in defensive situations.



## PART I : HANDLING OF A POINT 22 RIFLE

2. Handling the Rifle entails **Holding, Loading, Cocking, Aiming, Trigger Operation, Firing and Unloading** the weapon while adopting various **Firing Positions**. It also entails **Stripping & Assembling** the weapon for cleaning and learning purposes.

3. **Holding & Loading.** In the Point 22 Deluxe Rifle, ammunition is filled one by one in the Magazine and then the Magazine is pressed into the slot made below the Rifle. Ensure that the ammunition is clean before loading. If Magazine is not available, then after assuming the firing position, the cocking handle is pulled back, the round is manually loaded into the chamber and the cocking handle is pushed forward.



4. Loading of ammunition must be carried out only on 'Orders', and no action should be taken without proper 'Orders'. Loading must be carried out properly and in a set sequence. The drill and the sequence to load a weapon using lying position is illustrated below:-

- (a) To assume lying position, take a long pace forward with the left foot and at the same time pass the Rifle into left hand, holding it at the point of balance.
- (b) Place the right hand on to the ground in line with the left foot. During this movement push the Rifle forward and lower it to the ground. The left arm will now be extended to the front. The legs must be kept apart.
- (c) Keep the Rifle on the right hand and move the elbow of the left hand until the target, left elbow, right shoulder and right leg come in a line. Now keep the right elbow at the place where the elbow is to the right and slightly below the shoulder.
- (d) Place the palms of both hands below the chin, close your eyes and feel the tension of the elbow. If there is tension in the elbow, then keep the elbow in the same place and move the elbow back and forth to remove the tension and mark the place of the elbow.
- (e) Once the position is taken, the filled magazine is loaded or the ammunition is loaded one by one directly into the chamber after every round is fired.





5. **Holding in Lying Position.** To take hold of the Rifle, push it into the shoulder very firmly. Place the Rifle at the 'V' position formed between the pen finger and thumb of the left hand. The hand guard should come over the right hand. All four fingers should be placed from the outside and the thumb from the inside along with the magazine. To strengthen the 'hold', place the left elbow on the ground and push it a little forward. If the Rifle is pointing upwards, move the right hand forward. If it is pointing down, move the right hand backward. If it is pointing to the left then move the body position to a little right. If it is pointing to the right then move the body position to a little left.

6. **Aiming.** Accuracy of the aim is essential for a successful shot. This is by far the most difficult operation, as the eye has certain limitations. Nevertheless, good shooting can only be obtained with consistency of aim. Normally 25 yds range is used for Deluxe .22 Rifle. The thumb rule for correct aim is as enumerated below:-

- (a) Focus on the target so that a clear picture is formed on the retina of the eye and one gets the true center of the target.
- (b) Hold the Rifle properly as taught, keep it upright and firm, aligned to the target.
- (c) Close the left eye and focus on the foresight with the right eye.
- (d) See the foresight through the back sight 'U'. The foresight should be seen clearly in the center of the U. The tip of the foresight must be aligned in the center and in level with the shoulder of the U.
- (e) This line formed, should further align with the point of aim.

7. **Trigger Control.** The third essential for accurate shooting is trigger operation. It should be done without disturbing the Aim. To achieve this, perfect co-ordination between eye, brain and operation of the forefinger on the trigger is required. It is achieved by conscious control of the body and thorough practice. It entails, independent action of the index finger, muscular control of the hands, holding of breath/ breath control (before pressing the trigger), co-ordination between the right eye, brain and right-hand index finger and an element of '**holding**' which essentially means hold the stance for as long as possible.

8. **Firing a Shot.** Accurate shooting can never be achieved without concentration. From the time correct holding is achieved, more than **five seconds** should not be taken to fire a shot. Dwelling too much on the aim causes the eye and muscles to tire which may result in inaccurate shooting. When the '**range**' is given, the firer should adjust the sights and await indication of the target. The sequence of firing a shot is given below:-

- (a) **Position.** On being ordered to get ready, the firer must take the firing position.
- (b) **Limber-Up.** Before any firing practice, it is advisable to carry out trigger operation exercise and sequence of action for firing a shot. This is termed as '**Limber-Up**' and its aim is to assist in coordination and tuning up of muscles, eye and brain.
- (c) **Bhar.** Cadet should load the ammunition, take aim and be ready to fire on orders 'Bhar'.
- (d) **Breathing.** Just before taking an aim, breathing must be gently restrained. It is important to coordinate, so that when the foresight comes to the point of aim, the breath is partially exhaled.



(e) **Firing.** On being ordered to Fire, the Cadet should press the trigger. For a second or two after firing, there should be no relaxation of the 'hold' or 'movement of trigger finger' or 'head'.

(f) **Follow Through.** The 'hold' on the weapon and 'point of aim' must be maintained until the bullet has left the barrel. Better still, firer should follow through until the bullet has reached the target.

(g) **Re-loading.** Immediately after follow through, on orders, reloading should be carried out.

(h) **Re-alignment.** Having reloaded, the firer should realign his sights approximately on the target and be ready to fire the next round.

9. **Unloading.** Once firing is over, order for "**Khali kar**" will be given. The magazine should be removed. The chamber be checked by pulling the cocking handle back. After this the weapon be cocked twice and on orders the trigger should be pressed keeping the rifle towards the target. On further orders, place the right hand on the ground below the right shoulder, draw up the left hand and stand up as quickly as possible.

10. **Safety Precautions.** Safety assumes paramount importance while handling any weapon. Ensuring this entails:-

(a) Pushing forward the safety catch, raising and drawing back the bolt knob, then examining the chamber and the magazine. When satisfied that both are clear, push the bolt knob forward and down, press the trigger again keeping the rifle towards the target and apply the safety catch.

(b) Inspecting the drill cartridges and ensuring that there is no live ammunition left or stuck in the barrel.

## **PART II : STRIPPING & ASSEMBLY**

11. **Stripping.** Before stripping, check that the number on the left side of the body corresponds with the number on the back side of the lever of the bolt. The removal is done in the following sequence:-

(a) Removal of the bolt is done by raising the back sight leaf and pushing forward the safety catch. Keep the left hand under the magazine with the middle finger on the restraining catch. Withdraw the bolt to the rear, turning the bolt head upwards and fold back the back sight.



(b) Press the magazine catch upwards and take out the magazine.



12. **Assembling.** The assembling of the Rifle is always done in the reverse order. Check the magazine and ensure that the magazine number is the same as that of the Rifle. Insert the magazine at its place and press it. Ensure that the magazine is fixed in its place. While assembling the bolt of Deluxe .22 Rifle the following points will be borne in mind:-

- (a) Bolt head to be fully tight.
- (b) Bolt head and guide rib as well as cocking piece and steel lug to be in one line.
- (c) Number inscribed on the bolt should tally with that inscribed on the Rifle.
- (d) Safety catch should be applied.
- (e) Insert the bolt by holding bolt lever with right hand and Rifle with the left. Push forward the bolt until it touches in the charger guide and turn the bolt head towards right till the click sound is heard. Now push forward, and press the trigger and apply the safety catch.
- (f) Set the sight by pressing the thumb spring with range increasing towards the muzzle side (adjust the thumb spring accordingly).

13. **Care and Cleaning.** The efficiency of the Rifle depends on two factors.

- (a) Maintenance of the Rifle.
- (b) Skill of the firer.

14. The Rifle is designed to stand up to active service conditions but performance will be considerably affected if it is subjected to unduly harsh conditions. Strip the Rifle, open the butt trap and remove the pull through and the oil bottle for cleaning. The pull through has three loops. Nearest the weight is for the gauge, the center for cleaning the barrel with flannelette and the end one for oiling the barrel and for use of the armourer. Cleaning to be carried out on following occasions:-

- (a) **Before Firing.** Clean the barrel to make it oil free. After every practice, use the pull through to keep the barrel clean from carbon deposit.
- (b) **After Firing.** Once firing is over, use the pull through to first clean the barrel of any soot, followed by using oil to keep it rust free. Open the parts and clean them before depositing the weapon in the Kote.
- (c) Apart from the above, in order to keep the weapon in a fit state to fire, weekly, monthly and quarterly cleaning should be carried out.

### **PART III : FIRING POSITIONS**

15. **Firing Positions.** You can fire from a .22 Rifle by assuming four firing positions. Keep in mind that holding, aiming and trigger operation should be correct in all of these.

- (a) **Lying/Prone Position.** The prone position is a Rifle firing position where the



shooter lies on the ground. It is considered the most accurate and stable position for shooting. The main characteristics of this position are as under:-

- (i) **Stability**. The prone position offers the maximum body support and stability.
- (ii) **Accuracy**. It is the most accurate position for long-distance shots.
- (iii) **Ease of Learning**. It is the easiest position to master and is often the first position learned.
- (iv) **Fundamentals**. It is the best position for learning the fundamentals of firing such as aiming, breath control and trigger operation.



#### **Here are some tips for using the prone position:-**

- **Body Position**. Angle your body to the left axis of the Rifle if you are right-handed. Keep as much of your body in contact with the ground as possible.
- **Support**. Use a bipod if available, or put a soft rest under your front hand or under the Rifle fore-end.
- **Muzzle**. Pay special attention to the muzzle of your Rifle, as there is greater risk that it will touch the ground.
- **Rising**. Before rising (getting up), place the Rifle on the ground, stand, then pick up the Rifle.
- **Vision**. The low angle of the prone position may limit your view of the target if there are tall grasses or bushes in-between. It is therefore important to clear the field of view before proceeding with the firing practice.



(b) **Kneeling Position.** The kneeling position is a firing position where the shooter sits on the heel of one foot and places the other foot pointing forward. **There are two types of kneeling positions:-**

(i) **High Kneeling.** Sit on the heel of the foot, with the shooting-side elbow more horizontal.

(ii) **Low Kneeling.** Sit on the side of the foot, with the shooting-side foot forward.



**Here are some tips for kneeling position while firing:-**

- **Elbow Placement.** For right-handed shooters, place the left elbow on the left knee. For left-handed shooters, place the right elbow on the right knee.
- **Supporting Arm.** Place the other elbow under the Rifle or against the body.
- **Use a Sling.** A sling can help create a stable position.
- **Use a Stick or Bipod.** If possible, use a stick or extended bipod to steady the front hand and Rifle.
- **Pivot Point.** Think of the belt buckle as the pivot point. To engage another target, shift the entire body.
- **Relax.** Relax in the position and open the eyes to see where the target is in relation to the foresight tip.
- **Freeze.** Think of the entire body as frozen to stay in the natural point of aim.



(c) **Standing Position.** The standing position is a Rifle shooting position that's considered the most challenging and requires a lot of practice. There are two main forms of the standing position: **the supported and free-arm positions.** In the supported position, also known as the "**arm-rested position**", one puts the elbow of the non-firing hand against one's hip. In the free-arm position, one leans forward with his/her arms out in front.



**Here are some tips for the standing position:-**

- **Stance.** Stand perpendicular to the target with your feet shoulder-width apart and pointing slightly away from the target.
- **Arm Position.** For right-handed shooters, the left hand holds the fore stick with the elbow pointing down, and the right hand holds the grip with the elbow pointing out. The supporting arm should be perpendicular to the firearm, with the forearm resting in the supporting palm. The supporting elbow can rest on your hip or rib cage.
- **Body Position.** Keep your body upright and your legs straight with soft knees.
- **Stability.** For more stability, you can place a fist or grip the Rifle near or under the trigger guard. You can also use a stick or sticks that are perpendicular to the Rifle to increase stability.
- **Natural Point of Aim.** It is important to find your natural point of aim, which is where your body naturally aims at while aiming down range.



(d) **Sitting Position.** The sitting position is a steady shooting position that involves supporting both arms with one's legs.



**Note :** This position is only for teaching purpose, however, this firing position is generally not adhered to, either for practice or for any competition.

**Here are some tips for firing in the sitting position:-**

- **Leg position.** One can sit with one's legs apart or crossed. If the legs are apart, one can dig one's heels into the ground.
- **Arm position.** Rest the elbows on the inside of the knees, or in front of them if flexible. Avoid letting the elbows touch the kneecaps.
- **Body position.** Lean forward to rest on the legs. Turn the body 45-60 degrees away from the target.
- **Rifle position.** Place the buttstock of the Rifle on the right shoulder, close to the neck. Hold the Rifle's pistol grip firmly in the right hand to support the trigger finger.
- **Face position.** Place the face firmly against the stock, with the dominant eye looking through the sights.
- **Sling.** Use a sling to support the Rifle. Place the sling across the back of the left hand, and then across the chest and behind the left arm.
- **Steady the Rifle.** Use a stick or extended bipod to steady the fore-end of the Rifle.



## CONCLUSION

16. Having learnt the characteristics of .22 Rifle, the cadets have learnt about handling the weapon.
17. Easy to handle, it is the ideal weapon to start firing with.
18. Having learnt the process of stripping, assembling and cleaning the weapon, the Cadets will be able to handle the weapon and ensure its serviceability.
19. The positions used for firing need to be further practised by the Cadets so as to be proficient at it and be fully prepared before going to the range.

## SUMMARY

- **Handling the .22 Rifle.** Emphasis is laid on safe handling practices, including treating the Rifle as loaded always and being aware of the surroundings.
- **Stripping and Assembly.** It outlines the steps for safe assembly and stripping of .22 Rifle. It also highlights the importance of keeping the rifle clean along with the periodicity.
- **Firing Positions.** Covers various firing positions, such as prone, sitting, kneeling, and standing. Each position is explained in terms of stability and aiming techniques.
- Overall, the chapter aims to provide a comprehensive understanding of safe and effective Rifle handling and maintenance including various firing Positions.

**ASSESSMENT EXERCISE****Multiple Choice Questions**

Q1. .22 Rifle has \_\_\_\_\_ parts.

- |        |        |
|--------|--------|
| (a) 12 | (b) 18 |
| (c) 15 | (d) 14 |

Q2. How can ammunition be loaded into the rifle?

- |                       |                               |
|-----------------------|-------------------------------|
| (a) Magazine          | (b) Manually into the chamber |
| (c) Both of the above | (d) None of the above         |

Q3. When a firer is uphill and target is downhill then which position is the best for sighting the target?

- |                       |                      |
|-----------------------|----------------------|
| (a) Standing position | (b) Lying position   |
| (c) Kneeling position | (d) Sitting position |

Q4. During firing, if the Rifle suddenly stops firing then what procedure is carried out?

- |                      |                       |
|----------------------|-----------------------|
| (a) Pressing Trigger | (b) Removing Magazine |
| (c) Put Rifle down   | (d) Opening Rifle     |

Q5. How many types of firing position are there?

- |       |       |
|-------|-------|
| (a) 3 | (b) 4 |
| (c) 5 | (d) 2 |

Q6. What is most important for firing?

- |                               |                   |
|-------------------------------|-------------------|
| (a) Correct aiming            | (b) Holding tight |
| (c) Correct trigger operation | (d) All of these  |

Q 7. Which part of the .22 Rifle is stripped first?

- |                    |                    |
|--------------------|--------------------|
| (a) Bolt           | (b) Magazine       |
| (c) Re-Coil Spring | (d) Receiver cover |

Q 8. Which is the most stable firing position?

- |                       |                      |
|-----------------------|----------------------|
| (a) Standing position | (b) Lying position   |
| (c) Knelling position | (d) Sitting position |



- Q 9. How many types of kneeling positions are there
- (a) 1 (b) 2  
(c) 3 (d) 4
- Q10. When do we need to clean a Rifle?
- (a) Before putting in Kote (b) Before firing  
(c) After firing (d) All of these
- Q11. Chances of muzzle touching the ground is most probable in which position?
- (a) Standing position (b) Lying position  
(c) Knelling position (d) Sitting position
- Q12. Aim of \_\_\_\_\_ is to assist in coordination and tuning up of muscles, eye and brain.
- (a) Breathing (b) Trigger Control  
(c) Both of the above (d) Limber Up
- Q13. Before firing, the barrel should be \_\_\_\_\_.
- (a) Cleaned and oil be applied (b) Cleaned and oil be removed  
(c) Not cleaned (d) None of the above
- Q14. After firing, the barrel should be \_\_\_\_\_.
- (a) Cleaned and oil be applied (b) Cleaned and oil be removed  
(c) Not cleaned (d) None of the above
- Q15. Cdt should load the weapon on orders of \_\_\_\_\_.
- (a) Fire (b) Khali Kar  
(c) Bhar (d) Ready

### **Short Answer Questions**

- Q1. Bring out the steps in sequence of firing a shot.
- Q2. How does one carry out proper aiming?
- Q3. Why is prone the most accurate position for shooting?



Q4. Explain the types of kneeling positions.

Q5. Name the types of firing positions.

### **Long Answer Questions**

Q1. How does one ensure proper prone position?

Q2. Explain the stripping and assembling process.

Q3. Explain the tips for firing in kneeling position.



## WEAPON TRAINING (SD/SW)

### CHAPTER WT III : FIRING OPERATION OF RIFLE

***“In the hands of a skilled marksman, the bolt-action rifle is more than a weapon-it is an extension of patience, control, and mastery.”***



### TEACHING INSTRUCTIONS

**Period** : One (01)  
**Type** : Lecture  
**Year** : 1st Year  
**Conducting Officer** : Permanent Instructor.

**Training Aids** : Classroom or Squad Post Training, Charts, CBT or Audio-visual clips on Cycle of Operation and Automatic operations.

#### Time Plan

Introduction	:	05 Min
Part I - Brief on Cycle of Operation	:	10 Min
Part II - Introduction to Automatic Operations	:	10 Min
Part III - Introduction to Ballistics	:	10 Min
Conclusion	:	05 Min



## INTRODUCTION

1. The procedures that goes into firing a round are 'loading', 'cocking', 'firing', 'extraction' and 'ejection'. This entire thing is called cycle of operation, which can be automatic or semi-automatic. Point 22 Rifle works on bolt action operation. This cycle - chambering, cocking, firing, extracting, and reloading is manually controlled in a bolt-action rifle, giving the shooter full authority over every shot. It is a process that demands precision and deliberation, making bolt-action rifles a popular choice for accuracy dependent activities like hunting and long-range shooting.

### PREVIEW

The lecture will be conducted in the following parts:-

- Part I : Brief on Cycle of operation.
- Part II : Introduction to Automatic Operations.
- Part III : Introduction to Ballistics.

### LEARNING OBJECTIVES

- Introduction to the cycle of operation
- Specific to bolt action weapon
- Ballistics:-
  - Internal
  - External
  - Wound
- Understanding trajectory

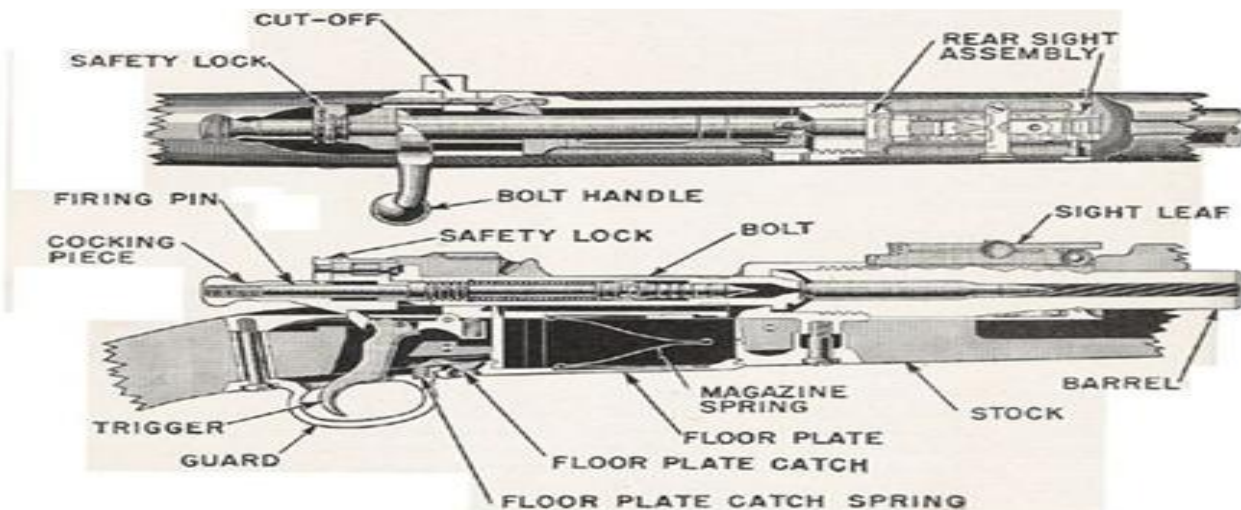

### INTERESTING FACTS

Firing operation is generally same for all firearms, regardless of their design or action type. The steps in the cycle of operation are:-

- **Feeding** : Cartridges are inserted into the chamber.
- **Chambering** : The cartridge is moved into its final position.
- **Cocking** : The firearm locks.
- **Firing** : The firearm discharges.
- **Unlocking** : The firearm unlocks.
- **Extraction** : The cartridge is extracted.
- **Ejection** : The cartridge is ejected.



## PART I : BRIEF ON CYCLE OF OPERATION

2. **Cycle of Operation.** The process of loading, cocking, firing, extracting, ejection and reloading is called cycle of operation. It is manually controlled in a bolt-action rifle. It is a process that demands precision and deliberation, making bolt-action rifles a popular choice for accuracy-dependent activities like hunting and long-range shooting.

3. In a weapon, on pressing the trigger, the bullet is fired towards the target. It moves out of the barrel with immense velocity towards the point of aim. The flight path of a bullet includes internal travel down the barrel, external path through the air, and terminal path through a target. **The science of the travel of a projectile in flight is called Ballistics.** The wounding potential of projectiles is a complex matter. The entire process can be clearly sub-divided into the following parts:-

(a) **Loading.** The process of placing the round inside the rifle either manually or in a magazine is called loading.

(b) **Cocking.** Once the cocking handle is pulled back and moved forward, the round enters the chamber and is ready to be fired.

(c) **Fire.** The moment the trigger is pressed, the hammer strikes the primer of the bullet. This gives a boost to the propellant present in the bullet case which ignites at a very high rate (Ignition of Propellant).

(d) **Production of Gas.** The controlled expansion of gases from burning propellant (gunpowder) generates pressure and the bullet is forced out of the barrel. As the bullet traverses the barrel of the gun, some minor deformation occurs, called setback deformation.

(e) Bullet travelling through a gun barrel is characterized by increasing acceleration as the expanding gases push on it, decreasing the pressure in the barrel as the bullet moves forward. Up to a point of diminishing pressure, longer the barrel, the greater the acceleration of the bullet.

(f) **Extraction and Ejection.** Once the bullet is fired, on pulling the cocking handle back, it extracts the empty case from the chamber and ejects it out of the Rifle.

## PART II : INTRODUCTION TO AUTOMATIC OPERATIONS

4. Automatic operation in rifle refers to a mechanism that allows the firearm to automatically cycle and chamber the next round after each shot without the shooter manually carrying out the action. In fully automatic rifle, the rifle continues to fire rounds as long as the trigger is kept pressed. Given below is the breakdown of automatic operation in firearms.

5. **Types of Automatic Operation.**

(a) **Semi-Automatic.** In a semi-automatic rifle, the rifle one round per trigger pull. After each shot, the rifle automatically ejects the spent casing and chambers the next round, ready for the next pull of the trigger. The firer must pull the trigger for



every shot.

(b) **Fully Automatic.** In a fully automatic rifle, multiple rounds are fired continuously as long as the trigger is kept pressed. The rifle automatically cycles and chambers each subsequent round until the magazine is empty or the trigger is released. In an automatic rifle, the firing and cycling are powered by gases or recoil generated when the bullet is fired. Here is the general cycle of operation for automatic rifles:-

(i) **Gas Operation (for many modern rifles).** As the bullet travels down the barrel, some of the expanding gases from the burning of the propellant are siphoned off into a gas tube or piston system. The gases push back on a bolt carrier or piston, cycling the bolt to the rear. As the bolt moves back, it extracts and ejects the empty case, feeds the next round and fires it. This operation continuous till the trigger is kept pressed.

(ii) **Blowback or Recoil Operation (in some designs).** The recoil or gas pressure from the fired round forces the bolt to slide backward, ejecting the spent casing, feeding the next round and then firing it.

(iii) **Extraction and Ejection.** The bolt or slide continues moving backward, extracting and ejecting the spent cartridge case from the chamber.

(iv) **Chambering the Next Round.** As the bolt moves forward again (driven by a spring), it picks up a fresh round from the magazine and chambers it, making the rifle ready to fire again.

(v) **Resetting the Action.** For fully automatic rifles, the mechanism allows the firing pin to reset and fire the next round as long as the trigger is still being pulled.

## 6. **Mechanisms that Enable Automatic Operation.**

(a) **Gas-Operated Systems.** Many modern automatic and semi-automatic rifles use gas from the fired round to cycle the action, such as the AR-15/M16 series or AK-47. The gases are diverted into a system that drives the bolt back to eject the fired round and load the next one.

(b) **Blowback Operation.** It is a system of operation for self-loading firearms that obtain energy from the motion of the cartridge case as it is pushed to the rear by expanding gas created by the ignition of the propellant charge. It is commonly used in small-caliber rifles and submachine guns.

(c) **Recoil-Operated Systems.** These systems use the energy of recoil of the firearm itself to cycle the action, like in some shotguns and older automatic rifles.

(d) **Difference between Recoil Operated and Blow Back.** Recoil operated firearms use the energy of recoil to cycle the action as opposed to gas operated or blowback operations using the pressure of the propellant gases.



7. **Fully-Automatic vs Burst Fire.**

(a) **Fully-Automatic.** The rifle will continue firing as long as the trigger is pressed, cycling through the rounds in the magazine.

(b) **Burst Fire.** Some rifles are equipped with burst-fire modes (often 2 or 3 round bursts), where pulling the trigger fires a set number of rounds before stopping, requiring another pull of the trigger to fire more.

8. Examples of Automatic Rifles are M16/M4, AK-47.

9. In summary, automatic operation in rifles involves a mechanism where the firearm automatically performs the tasks of extracting, ejecting and chambering after each shot, allowing for rapid or sustained fire depending on the design (semi-automatic or fully automatic).

### **ADVANTAGES OF AUTOMATIC OPERATION**

**Faster Rate of Fire.** The automatic cycling allows for a much faster rate of fire compared to manually operated firearms like bolt-action rifles.

**Ease of Use in Combat.** Semi-automatic and fully automatic rifles allow for more rapid response, especially in military and tactical situations.

### **DISADVANTAGES OF AUTOMATIC OPERATION**

**Less Control.** Fully automatic fire can be difficult to control, often resulting in reduced accuracy due to the increased recoil and rise of the barrel.

**Amn Consumption.** Fully-automatic operation consumes ammunition very quickly, which can be a disadvantage in situations requiring conservation of rounds.

## **PART III : INTRODUCTION TO BALLISTICS**

10. **Ballistics** is the science of projectiles and firearms, focusing on the movement and behavior of bullets and other objects in flight. As cadets, understanding the basics of ballistics is essential, as it helps explain how and why bullets behave differently after being fired from a weapon. Whether a person is using a rifle, a handgun, or another firearm, ballistics plays a crucial role in bullets hitting the target accurately. The flight-path of a bullet includes-internal travel inside the barrel, external path through the air and terminal path through a target. Thus, the three main types of ballistics one has to be familiar with are enumerated below:-

(a) **Internal Ballistics.** It is the study of the propulsion of a projectile and



refers to what happens inside the firearm from the moment the trigger is pressed until the bullet leaves the barrel. When the firing pin strikes the primer the propellant ignites, creating a small explosion that generates gas and builds pressure, propelling the bullet to move forward through the barrel. The length of the barrel, the condition of the firearm and the ammunition type can all affect how fast the bullet travels.

(b) **External Ballistics.** Once the bullet leaves the barrel it moves through the air, this is where external ballistics comes into play. Thus, external ballistics is that part of ballistics that deals with the behaviour of a projectile in flight. Many factors can influence the bullet's path, including gravity, air resistance, wind and the bullet's shape and speed. Understanding external ballistics helps predict where the bullet will land, which is crucial for aiming accurately, especially over longer distances. The external ballistics of a bullet's path can be determined by Initial Velocity, Gravity and Atmospheric Conditions which further determines the KE (Kinetic Energy) delivered at the target. The forward movement of the bullet is also affected by Drag (aerodynamic friction caused by air resistance). The rifling helps overcome the drag during flight. Rifling is a process of making spiral grooves inside the barrel of a gun which causes the bullets (when fired) to spin about its longitudinal longer axis to improve its aerodynamic stability and accuracy.

(c) **Terminal Ballistics.** It is the study of bullet behaviour once it impacts the target. This focuses on what happens when the bullet reaches its target. Terminal ballistics is all about how much energy the bullet transfers to the target, how deeply it penetrates and how the target reacts. Different materials-like wood, metal or a human target-will react differently based on the bullet's speed, shape and energy.

(d) **Wound ballistics.** The study of the effect of the projectile/ bullet on human body is called Wound Ballistics. It is concerning the wounding phenomenon and is part of Terminal Ballistics.

### **DID YOU KNOW?**

The speed at which a projectile must travel to penetrate human skin is 163 feet/second and to shatter bones is 213 feet/second, both of which are quite low, so other factors are more important in inflicting damage.

11. **Why Ballistics Matters.** A layman would always imagine a bullet travelling in a straight line. But ballistics makes us realise that it actually does not. A bullet does not travel in a straight line because of the force of gravity acting on it, causing it to drop downwards in its flight path, resulting in a curved trajectory, often described as a parabola, even from the moment it leaves the barrel; this is commonly referred to as "bullet drop". Key points are given below:-

(a) Gravity is the main factor. As soon as a bullet leaves the gun gravity pulls it downwards, causing it to deviate from a straight path.



(b) Air resistance also plays a role. While less significant than gravity, air resistance can slightly affect the bullet's trajectory by slowing it down and causing it to wobble slightly.

(c) **Impact on Aiming.** To hit a target at a distance, shooters need to aim slightly above the target to compensate for the bullet drop.

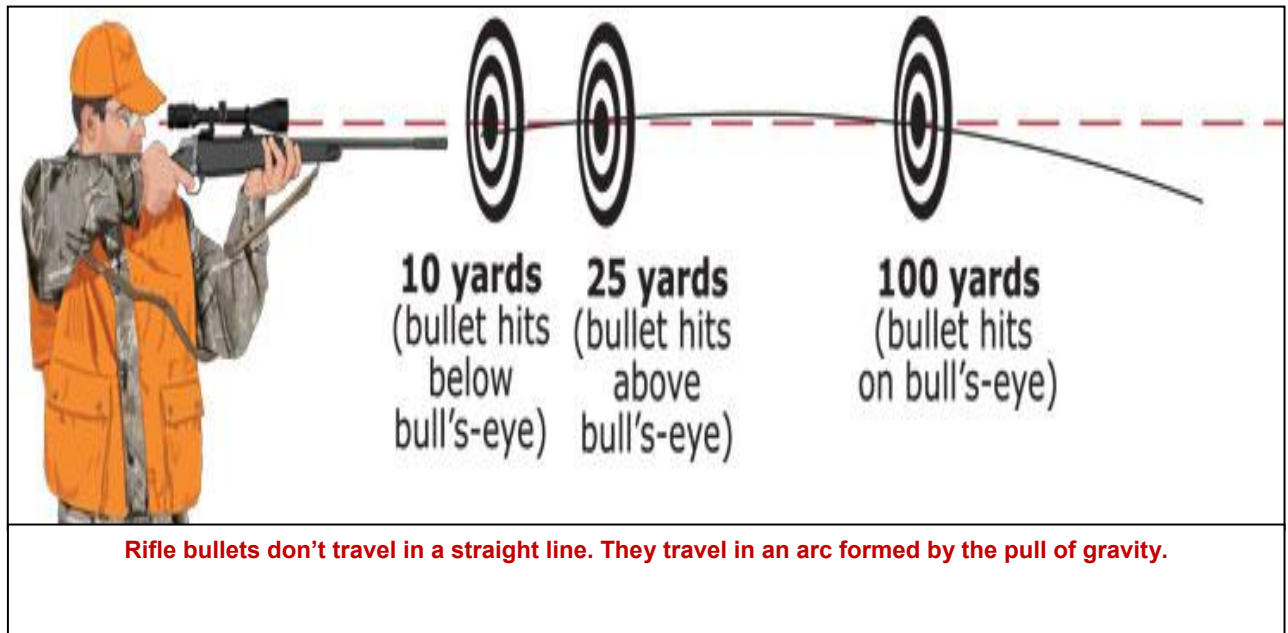

## CONCLUSION

12. Each rifle operation-automatic, semi-automatic or bolt-action-serves a distinct purpose based on the needs of the shooter.
13. Whether the goal is precision firing in competitions, sustained fire in combat, quick yet controlled shots in tactical scenarios or high precision in long-range engagements, understanding the differences in operation helps in selecting the right tool for the mission.
14. The choice ultimately depends on balancing speed, accuracy and reliability according to the intended use.
15. For young cadets, mastering the fundamentals of ballistics is not just about hitting targets; it is about safety, precision and understanding the equipment you are using.
16. A good grasp of ballistics will make one an efficient marksman and help take better decisions in the field.



## SUMMARY

**Based on the design, weapons have the following characteristics:-**

- **Automatic Rifles**. High rate of fire, effective for suppressive fire in combat, harder to control due to recoil and quick ammunition depletion.
- **Semi-Automatic Rifles**. Moderate rate of fire (one shot per trigger pull), good balance of speed and accuracy, easier to control and manage recoil. Ideal for both civilian and tactical uses.
- **Bolt-Action Rifles**. Slowest rate of fire, requiring manual cycling. Highest reliability and accuracy, especially at long range. Preferred for precision shooting and hunting. Minimal mechanical complexity, leading to fewer malfunctions.
- Each type has its own strengths and is suited for different roles: automatic rifles for overwhelming firepower, semi-automatic for balanced performance and bolt-actions for precision and reliability.
- Automatic rifles typically prioritize high volume over precision, making ballistics less focused on long-range accuracy.
- Semi-automatic rifles offer a balance where understanding ballistic performance can improve shot placement over moderate distances.
- Bolt-action rifles, often used for precision shooting rely heavily on detailed ballistic knowledge to maximize accuracy over long distances.
- Ultimately, a strong grasp of ballistics is essential for maximizing performance across different rifle types, ensuring that the shooter can make effective use of the weapon's inherent capabilities.



## ASSESSMENT EXERCISE

### Multiple Choice Questions.

- Q1. is the first step in cycle of Operation?
- (a) Locking (b) Extraction  
(c) Chambering (d) Firing
- Q2. Science of travel of a projectile in flight is called?
- (a) Firing (b) Ballistics  
(c) Chambering (d) Automatic Operations
- Q3. Backward movement of spent cartridge case is called?
- (a) Ejection (b) Chambering  
(c) Extraction (d) Locking
- Q4. In Fully Automatic weapon once the trigger is pressed and held what happens?
- (a) Continuous firing (b) Stop after 3 rounds  
(c) Stop after a round (d) Does not fire
- Q5. Study of the effect of the bullet on human body is called ----- ballistics?
- (a) Internal (b) External  
(c) Terminal (d) Wound
- Q6. \_\_\_\_\_ is the last step in cycle of Operations?
- (a) Locking (b) Extraction  
(c) Chambering (d) Ejection
- Q7. In semi-automatic weapons, \_\_\_\_\_ rounds are fired when trigger is pressed.
- (a) 5 (b) 3  
(c) 4 (d) 1
- Q8. Fully automatic weapon empties the magazine when\_\_\_\_\_.
- (a) Trigger is pressed once (b) Trigger is pressed and left  
(c) Trigger is pressed twice (d) None of the above



- Q9. Blow back operation uses \_\_\_\_\_ to function.
- (a) Gas (b) Force of spent cartridge  
(c) Recoil of firearm (d) None of the above
- Q10. Gas operation uses \_\_\_\_\_ to function.
- (a) Gas (b) Force of spent cartridge  
(c) Recoil of firearm (d) None of the above
- Q11. Recoil operation uses \_\_\_\_\_ to function.
- (a) Gas (b) Force of spent cartridge  
(c) Recoil of firearm (d) None of the above
- Q12. Advantage of automatic operations are.
- (a) Faster rate of fire (b) Accurate firing  
(c) Ammunition conservation (d) None of the above
- Q13. Disadvantage of Automatic operations are.
- (a) High rate of ammunition expenditure (b) Accuracy compromised  
(c) Both of the above (d) Slow rate of fire
- Q14. Study of effect of bullet on target is called as\_\_\_\_\_.
- (a) Internal Ballistics (b) External Ballistics  
(c) Terminal Ballistics (d) None of the above
- Q15. Study of movement of bullet in the barrel is called as\_\_\_\_\_.
- (a) Internal Ballistics (b) External Ballistics  
(c) Terminal Ballistics (d) None of the above

### **Short Answer Questions**

- Q1. Name the parts of Cycle of Operations.
- Q2. What are the mechanisms that enable automatic Operations?
- Q3. What is the difference between fully automatic and burst fire?
- Q4. List the type of ballistics.
- Q5. Why does a bullet not travel in a straight line?



### **Long Answer Questions**

- Q1. What is cycle of operations? Explain the process.
- Q2. Explain the cycle of operations of Fully Automatic Rifles.
- Q3. What are the advantages and disadvantages of automatic operations?

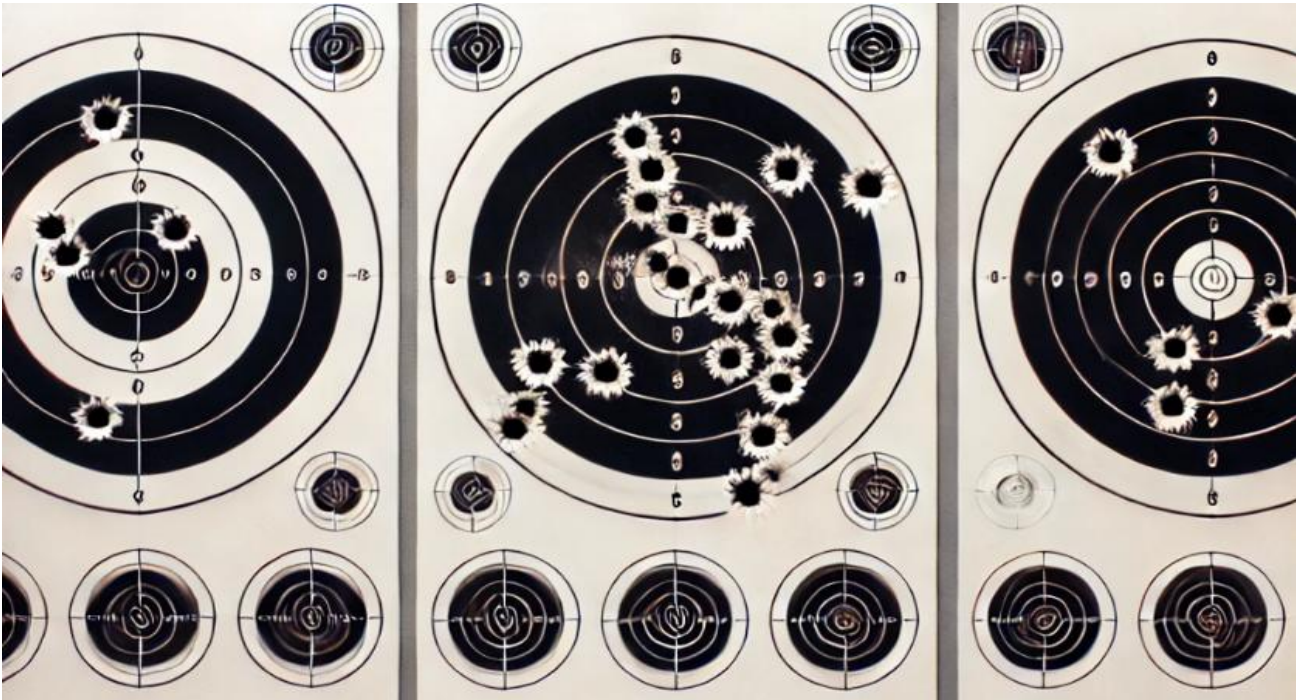
WEAPON TRAINING (SD/SW)CHAPTER WT IV : THEORY OF GROUPING & SHOT GROUP ANALYSISTEACHING INSTRUCTIONS

<b>Period</b>	:	Four (04)	
<b>Type</b>	:	Lecture	
<b>Year</b>	:	1 <sup>st</sup> & 2 <sup>nd</sup> Year - 02 Periods each	
<b>Conducting Officer</b>	:	Permanent Instructor.	
<b><u>Training Aids</u></b>	:	Classroom or Squad Post Training, Lesson Plan in File, Board and Markers, WT Gallery.	
<b><u>Time Plan</u></b>			
		<b><u>(1<sup>st</sup> Year)</u></b>	
		<b><u>(2<sup>nd</sup> Year)</u></b>	
Introduction	:	05 Min	05 Min
Theory of Groups	:	30 Min	10 Min
Concept of Master Eye	:	20 Min	10 Min
Sight Alignment and Picture	:	20 Min	10 Min
Shot Group Analysis & Types of Groups	:	-	10 Min
Errors During Firing	:	-	30 Min
Conclusion	:	05 Min	05 Min



## INTRODUCTION

1. The Theory of Grouping and Shot Group Analysis is fundamental to understanding the precision and accuracy of firearms. This chapter delves into how shots are clustered (grouped) on a target and what these patterns reveal about a shooter's performance, the rifle's consistency, and external factors affecting accuracy. Grouping refers to the consistency with which multiple shots hit the target in relation to each other, rather than just how close they are to the point of aim. A small shot group indicates high precision, while a wider spread suggests variability in shooting technique or external influences. This chapter also introduces key concepts such as mean point of impact (MPI) and standard deviation, which are used to statistically analyze shot patterns. By understanding grouping and performing shot group analysis, shooters can make informed adjustments to improve their precision and overall shooting performance.

### PREVIEW

The lecture will be conducted in the following parts:-

- **Part I : Theory of Groups.**
- **Part II : Concept of Master Eye.**
- **Part III : Sight Alignment & Sight Picture.**
- **Part IV : Shot Group Analysis & Types of Groups.**
- **Part V : Errors During Firing.**
- **Part VI : Conclusion.**

### LEARNING OBJECTIVES

- **Theory of grouping**
- **Concepts of hat**
- **Master eye**
- **Sight alignment & sight picture**

### INTERESTING FACTS

The smallest recorded shot group in history was achieved by legendary shooter Harold R. Vaughn, who achieved a five-shot group that measured only 0.009 inches at a distance of 100 yards! This level of precision is often cited as an example of what is possible with extreme attention to detail in fire arms tuning and environmental control.

In competitive shooting, sub-MOA (Minute of Angle) groups are considered the gold standard of precision. A 1 MOA group means that the shots are within a 1-inch circle at 100 yards. Elite snipers and marksmen strive to shoot even smaller groupings at much greater distances, such as 0.5 MOA or smaller.



## PART I : THEORY OF GROUPS

2. **Theory of Groups.** In shooting, the theory of grouping fire is a series of shots fired at the same point of aim will form a group, rather than all hitting the exact same spot.

(a) **Grouping.** The pattern of projectile impacts on a target from multiple shots fired in one session. The width of the grouping is a measure of the weapon's precision and the shooter's skill and consistency.

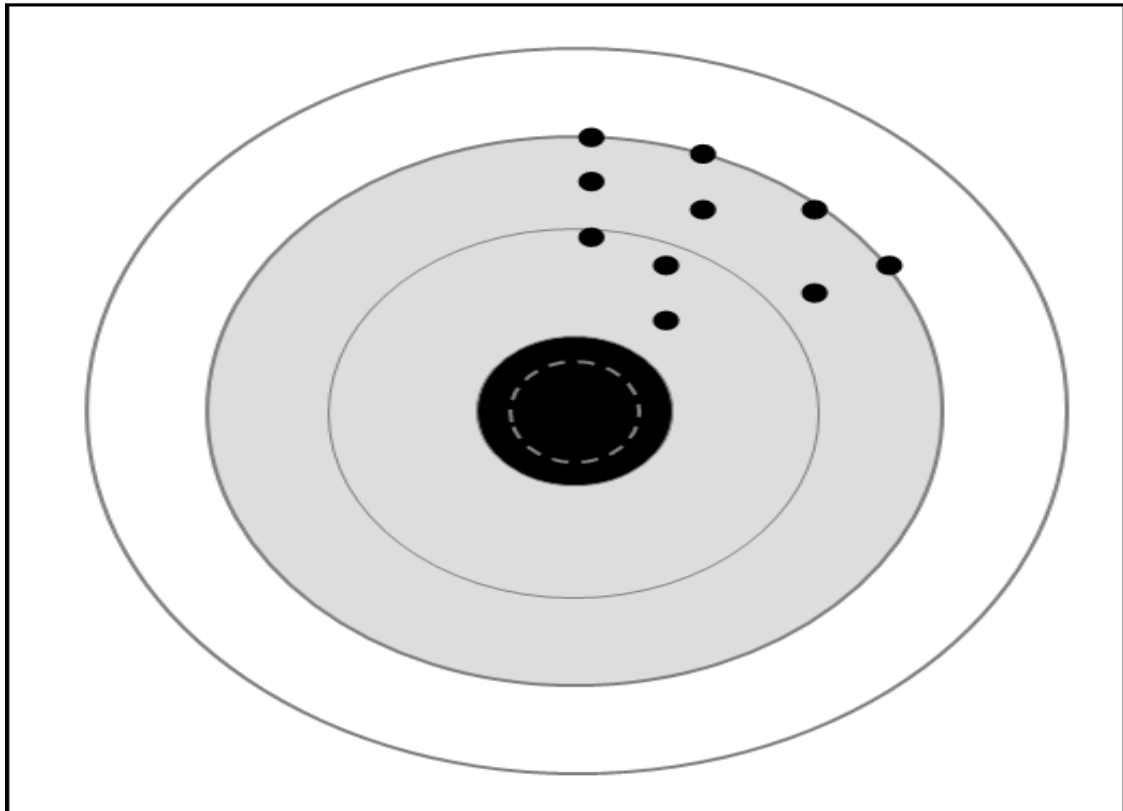

(b) **Grouping Displacement.** It is the distance between the calculated center of the group and the intended point of aim. This is a measure of accuracy.

(c) **Grouping Capacity.** It is the diameter of the circle that contains all the shots fired by a person to the best of their ability.

(d) **Ammunition.** The weight and charge of the ammunition can affect the size of the group.

(e) **Number of Shots.** A group can be as few as three shots, but five shots is ideal for generating detailed feedback.

3. The size of the group is affected by:-

- (a) The ammunition.
- (b) The rifle.
- (c) The firer.



## PART II : CONCEPT OF MASTER EYE

### 4. Concept of Master Eye.

- (a) Just as you have a dominant hand, you also have a dominant eye.
- (b) You need to aim with the dominant-or master-eye for the most accurate shooting. Usually, your dominant eye is the same as your dominant hand, but not always. You should determine which is your dominant eye before you sight-in your rifle.
- (c) To determine your dominant eye:-
- (i) Form a triangular opening with your thumbs and forefingers.
  - (ii) Stretch your arms out in front of you.
  - (iii) Focus on a distant object while looking through the triangular opening and keeping both eyes open.
  - (iv) Bring your hands slowly to your face, keeping sight of the object through the opening; the opening will come to your dominant eye naturally.
  - (v) If you're not sure, close one eye at a time. The weak eye will see the back of your hand; the strong one will be focused on the object in the triangle.

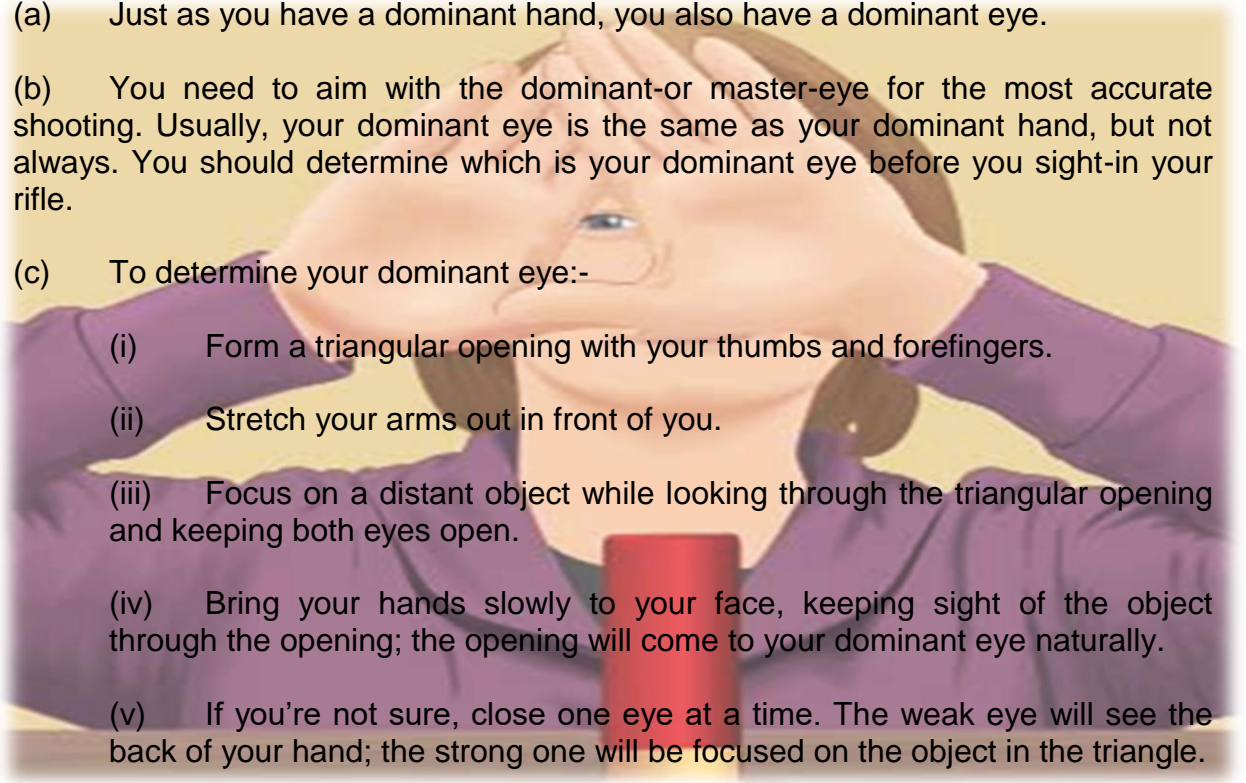

## PART III : SIGHT ALIGNMENT AND SIGHT PICTURE

5. Sight alignment is the relationship of the front sight to the rear sight. Sight picture is the relationship of your proper sight alignment to your intended target. In other words, are your properly aligned sights aimed at the point on your target you want your bullet to hit?

6. To obtain a proper **sight alignment**, the front sight or post is centered inside the rear sight. The top of the post should be even with the top of the rear sight.

7. A proper Sight Picture is obtained when the aligned sights are put into their proper relationship with the target.

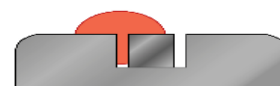
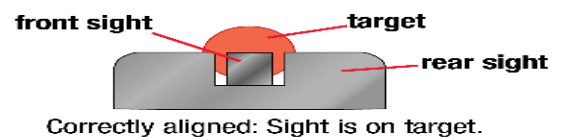

Incorrectly aligned:  
Bullet will go to the right of the target.



Incorrectly aligned:  
Bullet will go high and to the left of the target.



Incorrectly aligned:  
Bullet will go high.

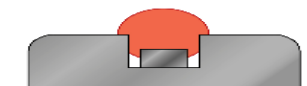

Incorrectly aligned:  
Bullet will go low.



## **PART IV : SHOT GROUP ANALYSIS**

8. **Group and its MPI.** During firing, it is important to know that when we ever fire more than one bullet, then all the bullets will not be fired at the same place on the target. There is a pattern which is formed, and there can be many reasons for it. To form a group, five bullets are fired simultaneously and at the same aiming point. The central point of the group of five bullets is called the Mean Point of Impact (MPI) of the group.
9. **Grouping Capacity.** The diameter of a circle of five bullets fired by a firer is called the grouping capacity of that firer.
- (a) As per the scoring, firers are classified according to their grouping capacity, such as 2 centimeters, 4 centimeters, etc. This grouping is measured at 25 meters.
  - (b) It should be noted that a firer's grouping capacity is estimated correctly only if he fires each bullet with the correct shot. If a bullet is fired by a firer accidentally, without a proper screen, then that bullet should be ignored for grouping capacity.
  - (c) Grouping is very important for weapon zeroing. If a firer fires five bullets carrying the same point of aim (POA) and his MPI is different from the point of aim, it means zeroing of the weapon needs to be done. For zeroing, some changes are made to the foresight or backsight so that the gap between MPI and POA is reduced.
  - (d) Once a firing rounds are grouped, it is the responsibility of the Firer to maintain his grouping from time to time and, if possible, to improve it further.
10. **Types of Groups.** A shot group is a pattern of the effects of multiple shots fired in a single session on the target. The width of the group, or how close the shots are together, is a measure of the shooter's skill and weapon accuracy. The distance between point of aim and group calculated center point is called Grouping Displacement, which is a measure of accuracy.
- (a) **Compact Group.** A Compact Group is formed when Holding, Aiming and Trigger Operations are followed correctly.
  - (b) **Scattered Group.** When Point of Aim and Grouping Displacement are away and the width of the group is stretched.
  - (c) **Bi-focal Group.** This happens when the Firer alternately focuses more on Point of Aim or Foresight Tip.



## PRECISION VS ACCURACY



✓ Precision  
✓ Accuracy



✗ Precision  
✓ Accuracy



✗ Precision  
✗ Accuracy



✓ Precision  
✓ Accuracy

### PART V : ERRORS DURING FIRING

11. **Errors During Firing.** Not being able to fire at point of Aim on a Firer's target or not making a compact group shows that the firer is making mistakes. Common mistakes are as follows:-

(a) **Bucking.** This is a common shooting mistake that occurs when a shooter tries to control the recoil force before firing. This is done by pushing the shoulder forward, inside the arms.

(b) **Flinching.** The firer anticipates a recoil and unconsciously stresses his muscles. In this case, the firer can bounce or blink as soon as the round is fired.

(c) **Trigger Jerk.** Here the firer pulls the trigger to shoot sharply, which can cause the Sight Picture to be wrong and the shot may miss the target.



12. **Reasons for Washout.** There are two main reasons for washout. Firstly, when the firer closes his master eye, and secondly when the sight alignment is wrong. It is because of these reasons that the bullet will completely miss the target.

### CONCLUSION

13. The Theory of Grouping & Shot Analysis is a fundamental aspect of weapon training that enhances a marksman's understanding of precision and consistency.

14. Grouping refers to the ability to place multiple shots within a compact area on a target, which is critical for assessing shooting skills.

15. The analysis of these shot groups allows shooters to identify patterns, diagnose errors, and make necessary adjustments to improve accuracy.

16. By knowing the errors being made while firing and then improving upon them, less or minimal mistakes are expected during firing competitions.



### **DID YOU KNOW?**

Military snipers often practice extensive shot analysis at various distances to understand how their weapon behaves in different conditions, allowing them to make instant adjustments in the field.

### **SUMMARY**

- **The chapter on Theory of Grouping & Shot Analysis** focuses on the principles and techniques crucial for improving shooting accuracy and consistency. Grouping refers to the ability of a shooter to place several rounds in a tight cluster on a target, demonstrating precision and control. The process of shot analysis involves studying the placement of these shots to identify shooting errors, such as incorrect sight alignment, poor trigger control, or external influences like wind and distance.
- By analyzing shot patterns, shooters can diagnose common issues like flinching, pulling the trigger incorrectly, or adjusting sights inaccurately. This analysis aids in improving one's overall shooting performance by helping to fine-tune skills.
- The chapter also emphasizes the importance of disciplined practice, where regular grouping and shot analysis allow shooters to progressively refine their skills, making adjustments as needed to achieve better accuracy. Ultimately, mastering these techniques is essential not only for individual skill development but also for operational success in military and tactical settings where precision is paramount.



## ASSESSMENT EXERCISE

### Multiple Choice Questions

- Q1. What is the pattern of projectile impacts on a target from multiple shots fired.
- (a) Ballistics (b) Grouping  
(c) Shot Gp (d) MPI
- Q2. What is the relationship of the fore sight to the rear sight.
- (a) Sight Picture (b) MPI  
(c) Sight Alignment (d) Shot Analysis
- Q3. Grouping is tested by firing minimum \_\_\_\_\_ rounds.
- (a) 3 (b) 4  
(c) 5 (d) 6
- Q4. What is the Distance between pt of aim and group calculated center pt.
- (a) Grouping Displacement (b) Gp picture  
(c) Gp Alignment (d) Grouping Accuracy
- Q5. If precision and accuracy are correct where will the bullet hit?
- (a) Top center (b) Centre Left  
(c) Bottom Centre (d) Pt of Aim
- Q6. The diameter of the circle that contains all the shots fired by a person to the best of their ability.
- (a) Grouping Capacity (b) Grouping picture  
(c) Grouping Alignment (d) Grouping Accuracy
- Q7. The size of the group is affected by\_\_\_\_\_.
- (a) The ammunition (b) The rifle.  
(c) The firer. (d) All the above
- Q8. Relationship of the fore sight and rear sight to the target.
- (a) Sight Picture (b) MPI  
(c) Sight Alignment (d) Shot Analysis
- Q9. The central point of the group of five bullets.
- (a) Compact Group (b) Grouping  
(c) Shot Gp (d) MPI



Q10. Weapon is zeroed if \_\_\_\_\_.

- (a) MPI and POA are same
- (b) MPI and POA are afar
- (c) MPI is in centre and POA to right of target
- (d) POA is in centre and MPI to right of target

Q11. A firer can form \_\_\_\_\_ types of Groups.

- (a) 2
- (b) 3
- (c) 4
- (d) 5

Q12. Group formed by incorrect trigger operation.

- (a) Compact
- (b) Scattered
- (c) Bi-Focal
- (d) None of the above

Q13. When POA and grouping displacement are close \_\_\_\_\_ Group is formed.

- (a) Compact
- (b) Scattered
- (c) Bi-Focal
- (d) None of the above

Q14. Firing error of pushing shoulder forward is called \_\_\_\_\_.

- (a) Bucking
- (b) Flinching
- (c) Trigger Jerk
- (d) None of the above

Q15. Firing error of blinking as soon as the round is fired is called \_\_\_\_\_.

- (a) Bucking
- (b) Flinching
- (c) Trigger Jerk
- (d) None of the above

### **Short Answer Questions**

Q1. What are Grouping and Grouping Displacement?

Q2. What affects the size of a group?

Q3. What is difference between sight alignment and sight picture?

Q4. What is Group and its MPI?

Q5. How do you know that the firer is making mistakes?

### **Long Answer Questions**

Q1. Explain concept of Master Eye. How do you determine it?

Q2. What are the types of Groups? Explain?

Q3. Explain the errors that occur during firing.



## WEAPON TRAINING (SD/SW)

### CHAPTER WT V : RANGE PROCEDURE & SECURITY OF RANGE



#### TEACHING INSTRUCTIONS

<b>Period</b>	: Three (03)
<b>Type</b>	: Lecture cum Practical
<b>Year</b>	: Each Year- 01 Period
<b>Conducting Officer</b>	: Permanent Instructor.

**Training Aids** : Classroom or Squad Post Training, Lesson Plan in File, Board and Markers, Targets and Target Papers.

#### Time Plan

• Introduction	:	05 Min	} For all the three years
• Preparation Before Firing.	:	05 Min	
• Range Procedures	:	05 Min	
• Range Documentation	:	05 Min	
• Application of Fire	:	10 Min	
• Firing Practices	:	05 Min	
• Conclusion	:	05 Min	



## INTRODUCTION

1. To maintain their shooting proficiency, troops practice at range with pistol, carbine and rifle. In our country, short ranges are found in almost every unit but classification ranges are few in numbers. Most NCC Units therefore find it difficult to find appropriate ranges for firing. If one is proficient in the steps required to be taken in order to prepare for firing, lot of time will be saved and max time available can be utilised for the basic firing practise. To take full advantage of the range allotment, preparations before the fire and executing a proper range drill at the range can give practice to all the cadets taking part in firing. Once this is done, firing practice can be carried out with full earnest. Not only can cadets be prepared for competitions but identification of good firers can also be carried out and nurtured thereafter.

### PREVIEW

The lecture will be conducted in the following parts:

- Part I : Preparation Before Firing.
- Part II : Range Procedures & Safety
- Part III : Range Documentation.
- Part IV : Application of Fire.
- Part V – Firing Practices.
- Part VI – Conclusion.

### LEARNING OBJECTIVES

- Understanding range procedures
- Preparation for firing
- Security of range
- Essential documentation
- Application of fire
- Firing practices & competition

### INTERESTING FACTS

- Preparation before firing and executing a proper range drill is as important as firing.
- Application of fire involves using controlled fire in various training scenarios
- Grouping forms the basis of application practices
- Once the grouping capacity of the firer is assessed, it will be his duty not only to maintain this capacity, but to improve on it eradicating any faults he might have had in earlier practices.



## **PART I : PREPARATION BEFORE THE FIRING**

2. To hone their skills and accomplish proficiency in their profession, troops practice at ranges with various small arms. To take full advantage of the range allotment, preparations before the fire and executing a proper range drill at the range can provide more time to all the trainees to carry out firing practice.

3. The range standing orders should be prepared as per the range so that the fire can start on time and there is no accident during the fire. The following points should be included towards preparations of the range:-

- (a) A 20 feet high staff pole on the right edge of the stop butt with a 6 x 6 feet red flag on it.
- (b) The soil of the stop butt is soft and that it does not have stones or other hard objects.
- (c) Targets should be 20 feet inward from the outer edge.
- (d) The stop butt should have a 2x2 feet round target number plate.
- (e) A 4x4 feet red flag is placed on a 12 feet pole on the left side of the Markers gallery.
- (f) Firing points and trenches should have sand bags filled with soft soil as per format.
- (g) The area should be clean.

4. The following locations must be earmarked and designated on one side of the range.

- (a) For collecting and depositing the Ammunition.
- (b) For the Armorer with his tools and equipment.
- (c) Nursing Assistant.
- (d) A telephone line must be laid for the connection along with the radio set.
- (e) Sentries, as per standing order, should be in red coat/sleeve.



## PART II : RANGE PROCEDURE AND SAFETY PRECAUTIONS

5. **Use of Red Flags.** No firing can take place until all the red flags are hoisted and look-out men posted as per the range standing orders. One flag will always be on the top of the butt. Flags are a warning that the range is in use.
6. **Suspension of Firing.** If firing is suspended during the practice owing to some unforeseen event, weapons will be placed on the ground and the firer will stand clear.
7. **Inspection of Weapons.** The officer in charge of the firing point is responsible to ensure that all weapons are cleared and inspected before leaving the firing point.
8. A further inspection will be carried out at the conclusion of firing. During inspection, loading and unloading, all the rifles must point towards the target. On the command ***Nirikshan ke lie Janch Shashtra'*** (Examine Arms) rifles will be held parallel to the ground and pointing in the direction of the target. No one will go to the target area until all weapons have been unloaded, inspected and permission to go has been given by the officer in charge.
9. Only firers, coaches (PI Staff), the firing point officer and his assistants are allowed on the firing point. Waiting details must be at least 10 yards from the firing point or in the shelter provided.
10. **The following is the normal procedure on the firing points:-**
  - (a) The party to fire is brought within about 100 yds of the firing point.
  - (b) The practices to be fired are explained.
  - (c) Firers are allocated target on which they have to fire.
  - (d) The PI staff, ammunition party and look out men take up their positions.
  - (e) The first two details only form up behind their respective targets on the firing point.
  - (f) On the order of '***Aage Barh'*** (Detail Advance) the first detail will take position on the firing point.
  - (g) On the lowering of the red flag at the butt, the officer supervising the firing point may order his red flag to be taken down and give the order of 'Detail Advance'. The PI staff now checks up their positions and corrects them if needed and gives the word of command '***Limber Up'***. On this, the firers must align their rifles to the target. The officer will then give the order to load and Fire.
  - (h) The firing will start only after getting orders from officer-in-charge firing.
  - (j) On completion of fire, the firers must raise their right hand up, keeping the elbow on the ground.



- (k) Officer-in-charge will give the word of command '**Khali Kar**' (before this he must ensure that all firers have finished firing). On this the firers will take their rifles onto their shoulders and move the bolt twice, press the trigger and stand up.
- (l) The officer-in-charge will give the command 'Detail Report'. On this the firers would report '**Number ek rifle theek, do theek, teen theek and number char rifle theek**'. The report will be from left to right (Normally four targets are used on miniature range).
- (m) The first and last firer will say '**Number ek/char rifle theek**' and the rest will say '**Do theek, teen theek**' and so on.
- (n) The details are changed by word of command and the new detail which has been waiting comes up while another detail forms up behind (Here the word 'detail' implies the number of firers who fire together at a point of time).
- (o) Before the firers leave the range, they will have a further weapon inspection. Each firer will be asked whether he/she has any live ammunition. It will be ensured that they have no live ammunition.

#### 11. **Safety Precautions.**

- (a) Treat all rifles as loaded. Always treat a rifle as if it has a bullet in the chamber, even when it is unloaded.
- (b) Always point the rifle in a safe direction, such as down range or towards the ground. The rifle is never pointed towards any individual. This is especially important when loading or unloading the rifle.
- (c) Keep the finger off the trigger until ready to shoot.
- (d) Know the target. Be sure of the target and what is behind, in front of it and around it.
- (e) Wear eye and ear protection as appropriate.
- (f) Be aware of range status. Check with others to ensure firearms are unloaded and the range is declared "SAFE" before firing. Stop shooting immediately when anyone calls "Cease fire".
- (g) If there is weapon malfunction or accidental discharge, same should be reported immediately.
- (h) In case of medical emergency, the Nursing Assistant must give immediate first aid and if required, the patient should be rushed to nearest hospital.



### **PART III : RANGE DOCUMENTATION**

12. **Range Documentation**. The following documents are to be maintained at the range during firing practices:-

- (a) Firing Point Register
- (b) Butt Register
- (c) Range Course SAO12/S/85 (new RANGE course)
- (d) No Damage Certificate
- (e) Ammunition and Fired Case Register
- (f) Range Clearance Certificate
- (g) Range Allotment Letter with timings of firing clearly specified.
- (h) Before and After Firing Inspection Register
- (j) Firing Record Register

### **PART IV : APPLICATION OF FIRE**

13. In the context of range firing, application of fire involves using controlled fire in various training scenarios like target practice, Fire Control Techniques, Live-Fire Exercises, safe handling and operation of firearms including how to manage misfires or other dangerous situations, Ballistic Testing and Tactical Drills.

14. Although the Open Sight Range has the variables of 100 meters, 75 meters, 50 meters and 25 meters, but Firing in NCC is always restricted to 25 meters other than the competitions like IDSSC where the firing is done at 50 meters. However, the Zeroing will always be carried out at 25 metres.

15. Overall, the application of fire in range firing is focused on skill development, safety and tactical effectiveness. As elucidated earlier, when firing a series of shots with a supposedly constant aim and under the same conditions, all rounds will not hit the same spot however perfect the firer may be or even the weapon and its ammunition. A pattern will always be formed.

16. For the purpose of training a group will imply five consecutive well-fired shots, fired with consistent aim at the same aiming point. The central point of impact is the Mean Point of Impact (MPI) of the group.



## 17. **Grouping Capacity**

- (a) The diameter of a circle containing all five shots, fired by the firer to the best of his ability, is known as his grouping capacity.
- (b) For the purpose of coaching and scoring, firers are classified into certain grouping capacities and measured at a range of 25 meters. These capacities are represented by the diameter of the circles e.g. 2 inches, 4 inches and so on.
- (c) A firer's grouping capacity, while remaining fairly constant at any given range, varies in proportion to the range at which firing is taking place. Thus, once a firer's grouping capacity at 25 meters have been ascertained, his capacity at any other range can be calculated by simple arithmetic. Hence, should the group be centrally placed, the scores expected on target can also be predicted.

18. **Declaration.** It must be appreciated that a group is representative of a firer's capacity, only when, correct aim has been taken for every shot. Should a firer accidentally fire when aim is not correct, he must note very carefully where the sights were pointing at the moment of firing and declare the fact. If on checking it is found that a bullet has gone astray and not at the place declared by the firer, it should be ignored for judging his grouping capacity. For instance, if a firer was making a 4 inches group and because of one stray bullet he makes a 12 inches group, his grouping capacity will be considered as 4 inches.

19. **Application of the Grouping.** Grouping is of immense value to the firer. It forms the basis of application practice in which the firer's Point of Aim is applied to the center of the target carefully noting the MPI, making alterations to sighting or to the point of aim where necessary. In the early stages a PI Staff will help the firer for this purpose.

20. If the position of the first shot is reasonably good and no error is declared, the second shot should be fired with the same aim. If the second shot is within the grouping capacity of the firer the probable MPI is the middle of the two shots. If MPI is too far out it should be adjusted for elevation and deflection. The correction should not be made boldly but with caution. The third shot will give the clear picture. If this MPI is again not central, a further cautious change should be made. After the fourth shot MPI position should be known and the fifth shot should be a good one fired with the correctly ascertained elevation and deflection.

## **PART IV : FIRING PRACTICES**

21. Once the grouping capacity of the firer is assessed, it will be the duty not only to maintain this capacity, but to improve on it eradicating any faults in early shoots. The Cadets are put through the following firing practices.

### 22. **Miniature Range Snap Shooting.**

- (a) A firer starts with grouping fire followed by application fire.



(b) After grouping and application fire has been done, the snap shooting should be carried out. This is to defeat the time factor. Initially it should be carried out on miniature range to make the firer gain confidence and realize that the exposure of target is enough to get a deliberate round fired and that the firer must be calm and composed throughout. In fact, before the fire, the firer should be given adequate practice on the following aspects: -

- (i) Concentration.
- (ii) Speed of co-ordination between eye and hand.
- (iii) Practice in dominating impulse.

23. The practice is given in the following stages:-

(a) **Stage-1 Automatic Alignment.** The aiming mark is given at the centre when the squad is lying in semi-circle with instructor in the center. The alignment is checked with the help of aiming disc when the individual on the command 'Up' aims at the Aiming Mark.

(b) **Stage-2 Automatic Alignment with Correct Hold and Trigger Operation.** On the command '*Up*' the firer brings up the rifle, aims, holds the rifle correctly and presses the trigger. He reloads when the rounds would have left the barrel for certain (It is best to emphasize this by a distinct pause), comes down and declares his shot, if incorrect, to the instructor. There is no time limit initially, only 'Accuracy before Speed' is insisted.

(c) **Stage 3, 4 & 5.** Practice firing and even competitions are carried out at figure 11 miniature target and snap shooting done at a range of 25 meters/yards.

(d) **Time.** Five exposures of seven second each is given at a regular interval over a period of 1.5 minutes. Interval between the exposures will not be less than six seconds. A trial exposure will be given to start with. Rifles may be loaded and firers may be in aimed position, before each exposure. Where facilities for pop up targets are not available, timings will be controlled from the firing point by means of a whistle. For subsequent fire, rifle will be loaded but not at aiming position. This will be raised only after the whistle is blown for each exposure. Good holding is essential.

(e) **Stage 6.** Practice is given at range, sighting at figure 11 miniature target.

(f) **State 7.** The range snap shooting practice is carried out.

## **CONCLUSION**

24. Following range procedures and security protocols is essential for maintaining a safe environment during firing.

25. Strict adherence to the established rules not only ensures the safety of the firers and range staff but also contributes to the effectiveness of the training.

26. Proper communication, proper documentation, clear signals, and the vigilance of range officers are key factors in preventing accidents.



27. The security of the range both in terms of physical safety and the secure handling of weapons and ammunition is paramount.

28. By adhering to these guidelines, shooters can focus on their training while minimizing risks, creating a controlled and efficient learning environment.

### SUMMARY

- The chapter outlines the critical protocols and safety measures necessary for ensuring safe and efficient operations during weapon training exercises on a firing range. It briefly covers standard operating procedures (SOPs) that govern the setup and conduct at a range. This includes ensuring the correct positioning of targets, establishing firing lanes, and maintaining clear communication between range officers and firers.
- A major focus is placed on safety measures, such as handling firearms responsibly, the importance of wearing protective gears (like helmet, ear and eye protection) and the significance of following all instructions from range officers. The chapter also delves into documentation including security protocols, which aims to prevent unauthorized access to the range, ensure that weapons and ammunition are accounted for, and that no live rounds are left uncollected after a session.
- Additionally, it covers emergency procedures for incidents like firearm malfunctions, accidental discharges or medical emergencies, highlighting the need for range personnel to be trained in first aid and crisis management.

**ASSESSMENT EXERCISE****Multiple Choice Questions**

- Q1. Firing is done from\_\_\_\_\_.
- (a) Waiting Area (b) Hing Point  
(c) Stop But (d) None of the Above
- Q2. During 'Bhar' command, which action will be done at firing range.
- (a) Filling bullets into magazine (b) Filling bullets into chamber  
(c) Fitting magazine into Rifle (d) Trigger press
- Q3. Limber up means \_\_\_\_\_.
- (a) Firers must align rifles (b) Firers must start firing  
(c) Firers must Stop firing (d) Firers must Check target
- Q4. On orders of Fire \_\_\_\_\_action is taken: -
- (a) Firer moves towards firing butt (b) Cocking the Rifle  
(c) Fitting magazine in rifle (d) Starts firing
- Q5. In 'Khali kar' orders, rifle will be cocked.
- (a) 1 time (b) 2 times  
(c) 3 times (d) 4 times
- Q6. Red coloured flag at Stop Butt means\_\_\_\_\_.
- (a) Start Firing (b) Stop Firing  
(c) Only Grouping to be carried out (d) None of the Above
- Q7. Soil on the Butt should be \_\_\_\_\_.
- (a) Hard (b) Soft  
(c) Mixed with stone (d) None of the above
- Q8. On orders of Aage Barh
- (a) Start the fire (b) Details advance  
(c) Stop fire (d) Check target



Q9. On orders of "cease fire".

- |                        |                       |
|------------------------|-----------------------|
| (a) Firing to start    | (b) Firing to restart |
| (c) All firing to Stop | (d) None of the Above |

Q10. What are minimum rounds required to be fired to create a grouping?

- |       |       |
|-------|-------|
| (a) 3 | (b) 4 |
| (c) 5 | (d) 6 |

Q11. The center point of a Group formed is called?

- |           |                       |
|-----------|-----------------------|
| (a) Group | (b) Grouping Capacity |
| (c) MPI   | (d) None of the above |

Q12. Application fire is focused upon \_\_\_\_\_.

- |                            |                   |
|----------------------------|-------------------|
| (a) Skill development      | (b) Safety        |
| (c) Tactical effectiveness | (d) All the above |

Q13. Declaration is done when \_\_\_\_\_.

- |                            |                        |
|----------------------------|------------------------|
| (a) The aim is not correct | (b) The aim is correct |
| (c) All the above          | (d) None of the above  |

Q14. Firer should do firing in the following order:-

- |                                     |                                    |
|-------------------------------------|------------------------------------|
| (a) Grouping-Application-Snap Shot  | (b) Snap Shot-Grouping-Application |
| (c) Grouping-Snap Shot- Application | (d) Application-Snap Shot-rouping  |

Q15. Snap shot helps in defeating the \_\_\_\_\_.

- |                        |                       |
|------------------------|-----------------------|
| (a) Time Factor        | (b) Handling errors   |
| (c) Weapon malfunction | (d) None of the above |

### **Short Answer Questions**

Q1. Why is preparation before firing important?

Q2. Give three pts of preparation of a range.

Q3. Why is declaring of pt of aim correctly, important?



Q4. Why is it important to fix the range correctly while firing?

Q5. What practice should be given to a firer before firing?

### **Long Answer Questions**

Q1. What is the procedure followed for firing at the firing point?

Q2. List out the various range documents.

Q3. What are the main points to be observed in 'Continuous Snap Shooting'?



## WEAPON TRAINING (SD/SW)

### CHAPTER WT VI : SHORT RANGE FIRING

***"Taking my shot, one round at a time. Shooting for the stars, hitting every target. Stepping up my shooting game, one bullet at a time. When it comes to shooting, I'm a sharpshooter."***



### TEACHING INSTRUCTIONS

<b>Periods</b>	:	Nine (09).
<b>Type</b>	:	Practice
<b>Year</b>	:	2 <sup>nd</sup> Year - 03 Periods; 3 <sup>rd</sup> Year - 06 Periods
<b>Conducting Officer</b>	:	Permanent Instructor.
<b><u>Training Aids</u></b>	:	Short Range, Targets, Weapons, Ammunition.
<b><u>Time Plan</u></b>	:	0800 to 1600 hr



## INTRODUCTION

1. Having undergone training of handling weapons, its characteristics, maintaining it and the procedure and precautions to be adhered to at the ranges, the Cadets now need to undergo actual firing practice. One needs to ensure that firing should be done in a phased manner so that the cadets, who are carrying out live firing for the first time, get to experience the joy of competitive firing. If trained properly, the talented kids can be identified so that better training can be provided to them.

### PREVIEW

The lecture will be conducted in the following parts:

- **Part I : Grouping Fire.**
- **Part II : Application Fire.**
- **Part III : Snap Shot.**
- **Part IV : Conclusion.**

### LEARNING OBJECTIVES

- **Practicing the range procedures**
- **Preparation for firing**
- **Ensure range security**
- **Firing practices & competition**

## PART I : GROUPING FIRE

2. The Grouping fire will be fired as follows:-

- (a) Distance : 25 Mtrs/yards
- (b) Number of rounds : Five.
- (c) Position : Lying with rest.
- (d) Target : 1' x 1' Grouping Target.
- (e) Highest Points : 40
- (f) Time : Own Time
- (g) **Scoring**
  - (i) 2.0 cms & below : 40 Points
  - (ii) 2.5 cms & below : 36 Points
  - (iii) 3.0 cms & below : 32 Points
  - (iv) 3.5 cms & below : 28 Points
  - (v) 4.0 cms & below : 24 Points



(vi)	4.5 cms & below	:	20 Points
(vii)	5.0 cms & below	:	16 Points
(viii)	5.5 cms & below	:	12 Points
(ix)	6.0 cms & below	:	08 Points
(x)	6.5 cms & below	:	04 Points
(xi)	Above 6.5 cms	:	00 Points

### **PART II : APPLICATION FIRE**

3. The Application fire will be fired as follows:-

- |       |                       |   |                             |
|-------|-----------------------|---|-----------------------------|
| (a)   | Distance              | : | 25 Mtrs/ yards              |
| (b)   | Number of rounds      | : | Five.                       |
| (c)   | Position              | : | Lying without rest.         |
| (d)   | Target                | : | 1' x 1' Application Target. |
| (e)   | Highest points        | : | 40                          |
| (f)   | Time                  | : | Own time                    |
| (g)   | <b><u>Scoring</u></b> |   |                             |
| (i)   | Bull                  | : | 8 Points                    |
| (ii)  | Inner                 | : | 6 Points                    |
| (iii) | Magpie                | : | 4 Points                    |
| (iv)  | Outer                 | : | 2 Points                    |

(h) Similar practice will be carried out from Kneeling and standing (both supported and unsupported) position.

### **PART III : SNAP SHOOTING**

4. The Snap Shot fire will be fired as follows:-

- |     |                  |   |           |
|-----|------------------|---|-----------|
| (a) | Distance         | : | 25 Meters |
| (b) | Number of rounds | : | Five      |



- (c) Position : Lying without rest
- (d) Target : Figure 11 miniature
- (e) Highest points : 50
- (f) Time : Five exposures of seven seconds each

### **CONCLUSION**

5. Shooting practice is important not only for sports shooting but also for self defence development.
6. In order to develop these aspirations in NCC Cdts, it is necessary that firing practice at short ranges be undertaken with utmost sincerity.
7. The short time available as also the dearth of ranges implies that we should utilize these instances to the fullest.
8. Apart from giving all the cadets an experience at firing, identification and nurturing of talent is of utmost importance.

### **SUMMARY**

- The chapter outlines the types of practices the cadets need to undergo during firing at a range.
- Since identification of good firer is important, focus to be on grouping initially and application and snap shot subsequently.
- Additionally, the cadet gets to know the range procedures and firing precautions to be taken.



# **OBSTACLE** **TRAINING**



### **CHAPTER WISE INDEX - OT (SD/SW)**

<b>Ser No</b>	<b>Subject</b>	<b>Page</b>
1.	Introduction	186
2.	Obstacle Course and Negotiation	
3.	Dress	194
4.	Obstacles for Senior Wing Cadets	
5.	Practice in Negotiating the Obstacle Course	
6.	Safety Measures for Successful and Safe Completion of the Obstacle Course	195
7.	Benefits of Obstacle Course Training	
8.	Demonstration	197

## OBSTACLE TRAINING (OT)

### CHAPTER OT I : STANDARD OBSTACLE TRAINING

***“ Don’t let the obstacles in your path be the reason you give up. Let them be the reason you push harder.” - Unknown***



### TEACHING INSTRUCTIONS

<b>Type</b>	:	Lecture and Practice
<b>Year</b>	:	1 <sup>st</sup> , 2 <sup>nd</sup> & 3 <sup>rd</sup> Year SD/SW
<b>Conducting Officer</b>	:	Permanent Instructor and ANO
<b><u>Training Aids</u></b>	:	Class room, OHP, Board, Chalk/Markers & OT Area

#### **SD/SW**

<b><u>Distribution of Periods</u></b> :	1 <sup>st</sup> year - 3 Periods (1period theory and familiarisation 2 periods Practical on ground).
	2 <sup>nd</sup> year - 2 periods (Familiarisation and OT practice on ground)
	3 <sup>rd</sup> year - 2 periods (Familiarisation and OT practice on ground)



## INTRODUCTION

1. The National Cadet Corps (NCC) stands as one of India's foremost youth organizations, dedicated to instilling character, leadership, and discipline in its cadets. Central to its comprehensive training regimen is the focus on both physical fitness and mental resilience, essential qualities for shaping the leaders of tomorrow. Among its diverse training modules, obstacle course training holds particular significance, as it sharpens not only the cadets' physical strength but also their problem-solving abilities, teamwork, and leadership skills. This training builds confidence, cultivates courage, and strengthens willpower, empowering cadets to overcome any challenge or barrier in life. It equips them to tackle both physical and mental obstacles, fostering resilience that will benefit them in all facets of their personal and professional journeys.

### PART I : OBSTACLE COURSE AND METHODS OF NEGOTIATION

2. Obstacle training in the NCC is a rigorous and dynamic activity that blends physical exertion with mental resilience. Cadets must navigate a series of ten obstacles, each designed to teach proper techniques in jumping, balancing, scaling, and vaulting. This training plays a crucial role in fostering early fitness development among cadets. Every obstacle targets specific attributes such as strength, endurance, agility, coordination, and balance. The sequence of obstacles challenges cadets to think quickly, manage their energy efficiently, and maintain focus under pressure. The demanding nature of the course pushes cadets beyond their comfort zones, helping them uncover their true potential. The Standard Obstacle Course that NCC cadets must navigate comprises ten distinct obstacles, each spaced about 30 feet (10 yards) apart. Constructed from materials such as wood, bricks, concrete, and mud, these obstacles challenge cadets both physically and mentally. The course begins at the start line, and the cadets proceed to tackle obstacles in the following order: straight balance, clear jump, gate vault, zig-zag balance, high wall, double ditch, right vault, left vault, ramp, another straight balance, before finally crossing the finish line.

#### 3. Straight Balance

(a) **Description.** The obstacle consists of a wooden slab measuring 3 inches thick, 4 inches wide, and 12 feet long, positioned 1.5 feet above ground level.

(b) **Method.** The cadet crosses the slab by running with arms outstretched to maintain balance. This obstacle emphasizes body balance and coordination. Relaxation is key to successfully navigating obstacles where balance is crucial. A relaxed approach builds confidence and enables faster crossings, while tension often results in loss of balance or, at best, slower progress. The position of the head plays a vital role in maintaining balance and should be kept as upright as possible, especially when moving on narrow surfaces or at heights. The eyes should neither point directly downward which may cause instability and impose more caution, nor look straight ahead which can lead to missteps or chances of fall. Ideally, the focus should be about 3 meters ahead. Since rifles are carried during obstacle courses, it is important to learn crossing the obstacle without raising of arms sideways for balance.



#### 4. Clear Jump

(a) **Description.** Its structure resembles a straight wooden bar, 18 feet long and positioned 2 feet above the ground. The cadet must jump over the bar without touching it or using any part of the body for support.

(b) **Method.** After a short run toward the obstacle at a right angle, the cadet takes off from one foot. Both knees are then quickly raised high in front of the chest to ensure the feet clear the bar. To aid in lifting the body, the arms, slightly bent, swing forward as the knees rise. Once the obstacle is cleared, the knees and body extend, and the arms lower. The landing is executed by stepping off with one foot while moving the other just past the edge of the bar, jumping downward and slightly forward. Controlling body balance during both the flight and landing is key. The landing should be with feet and knees together, pointed forward, and with enough knee bend to absorb the impact, preventing jarring to the body

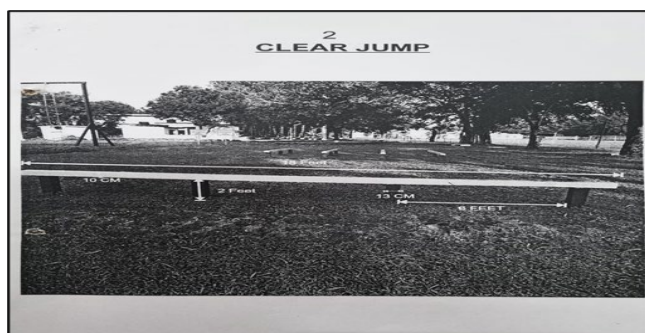



## 5. Gate Vault.

(a) **Description.** This obstacle consists of a wooden structure with two horizontal beams, positioned at heights of 3 feet and 5 feet, each 18 feet long.

(b) **Method.** To cross this gate, you must grip the upper beam with both hands, place your feet on the lower beam, and then jump across. This vaulting technique is particularly useful for overcoming gates. Begin with a short run-up, then take off from one leg, aiming to grip the top beam with both hands while jumping for the lower beam. Once you achieve balance, lean your torso forward and downward, moving one hand across to the opposite side of the structure until it aligns with the other hand. At this point, grasp the lower beam and roll your body over it. Common Faults in crossing gate vault is when cadet jumps instead of step up. Stepping up to the lower beam rather than jumping for it can result in a loss of speed and an uncontrolled landing.

(c) **Common Faults.**

(i) Stepping up instead of jumping up to the lower beam, which can result in loss of speed and lead to uncontrolled landing.

(ii) Keeping upper body balance back, which can lead to backward fall

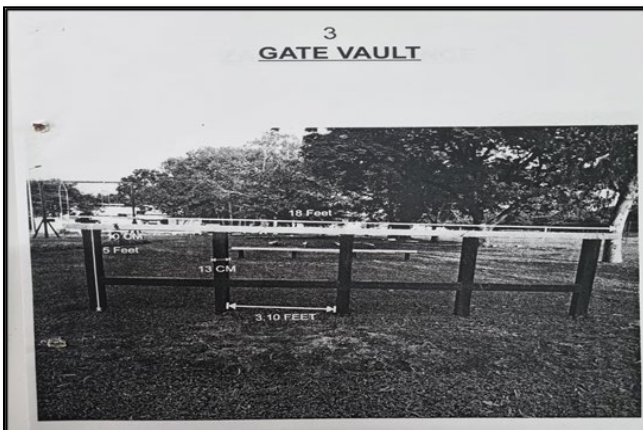

## 6. Zig-Zag Balance.

(a) **Description.** An 18-foot-long wooden beam, constructed in a zig-zag manner, 3 inches wide and 1½ feet above the ground.



(b) **Method.** The cadet crosses the beam while balancing the body in a zig-zag motion, with arms open for support.

(i) **Approach the Obstacle.** Begin with a steady, controlled pace as you approach the zig-zag balance beam. Maintain a relaxed posture and focus on balance.

(ii) **Initial Step.** Step onto the beam confidently with your dominant foot. Keep your arms outstretched to the sides for balance.

(iii) **Foot Placement.** Place your feet carefully, one in front of the other, ensuring each step is centered on the beam. Avoid long strides, as shorter, more controlled steps offer better balance.

(iv) **Zig-Zag Transition.** As you reach each turn in the beam, pivot smoothly on the heels of your feet. Maintain control and avoid rushing through the turns, as this is where balance is most easily lost.

(v) **Maintain Focus.** Keep your head upright and focus your eyes a few feet ahead of each step, rather than looking directly down at the beam. This helps with overall balance and coordination.

(vi) **Arm Control.** Keep your arms slightly raised and extended for stability but avoid exaggerated movements. Subtle adjustments help maintain balance throughout the course.

(vii) **Finish Strong.** As you approach the end of the zig-zag beam, maintain your focus and continue with the same controlled steps. Step off the beam confidently once you reach the finish.

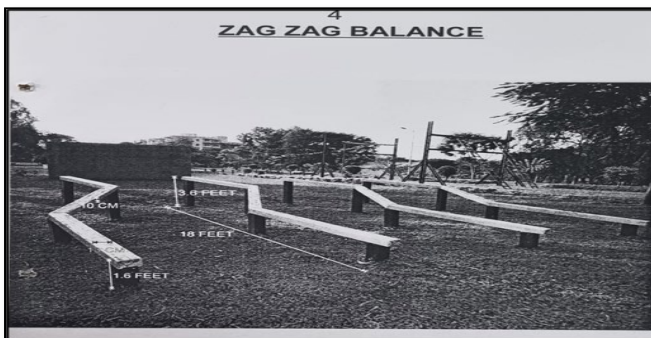



## 7. High Wall

(a) **Description.** The obstacle consists of a 6-foot-high, 12-foot-long bricked wall, plastered on both sides.

(b) **Method.** All cadets should try and cross this obstacle individually. For team exercises and for cadets who aren't able to cross it on its own, the "stirrup lift" team approach may be used.

In the **individual method**, the cadet runs towards the wall and leaps, kicking off the wall with one leg. Using both hands to grip the top, the cadet pushes upward, pulling their body onto the wall. Once gripping the top with both hands, the cadet bends their arms, first placing one forearm and then the opposite palm on the wall to gain leverage. This allows the cadet to roll over the top safely, rather than standing or sitting on it, minimizing exposure as also wasting time. In the **stirrup lift method**, used when teamwork is involved, two cadets stand against the wall facing each other. They form a "stirrup" by placing their hands on one cadet's bent leg, creating a platform for the climber. The climber steps into the stirrup and reaches for the top of the wall. As the lifters push up under his heels, the climber is propelled high enough to grasp the top and roll over. Like in the individual method, cadets should avoid sitting on the wall to prevent making themselves visible. Cadets are also trained in the correct descent method. After rolling over, they should hang down from the wall with fully extended arms, releasing one hand for balance. A strong push-off from the remaining hand should be made, turning their body so they land with their back to the wall, ensuring a safer landing

(c) **Common Faults.**

- (i) Approaching the wall with speed and abruptly stopping owing to miscalculation resulting in injury.
- (ii) Standing or taking a high position on the wall instead of rolling over





## 8. Double Ditch.

(a) **Description.** The obstacle consists of two ditches, each measuring 6-8 feet in length, 4-5 feet in width, and 3-4 feet in depth, with a small gap of 9-12 inches between them.

(b) **Method.** Begin with a preliminary run-up and take off from one foot. As you leap across the first ditch, place one foot on the small gap before jumping over the second ditch and landing across on the other foot. This maneuver requires precise agility and timing.

(c) **Common Faults are.**

(i) **Insufficient Speed.** A lack of speed during the run-up can hinder performance.

(ii) **Uncontrolled Flight.** Poor control during flight can affect your ability to clear the ditches.

(iii) **Lack of Height.** Inadequate height can lead to difficulties in clearing the obstacles.

(iv) **Uncontrolled Landing.** Landing on both feet instead of one, either in between the ditches or after the second one, will lead to body falling forward because of speed of motion. Ensure stable take off and landing on one foot

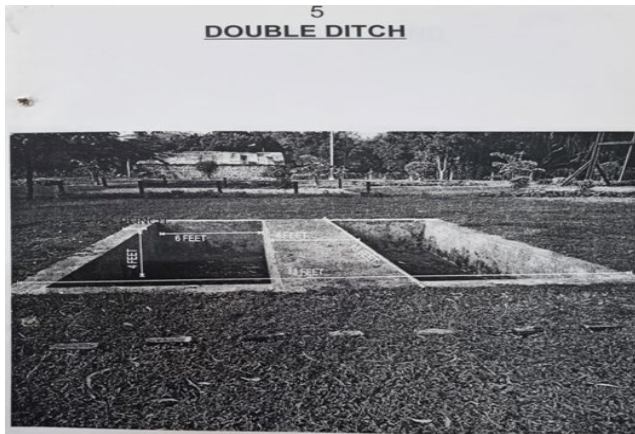



## 9. Right Hand Vault.

(a) **Description.** This wooden structure stands 3.5 feet above the ground and is 18 feet long. The cadet must jump over it by using the right hand for support while lifting both legs over the beam.

(b) **Method.** As far as possible, approach the obstacle straight, not from the side, and take off on one foot to cross the obstacle, while placing the right hand on top of the beam for support. The body's weight is shifted entirely onto the right arm as the cadet moves over the obstacle with the right side facing it. The landing be made on one foot to maintain momentum. Only right hand should touch the beam, violation of which incurs a penalty in competitions including TSC.



## 10. Left Hand Vault.

(a) **Description.** This wooden structure, similar to the Right Hand Vault, stands 3.5 feet above the ground and is 18.5 feet long.

(b) **Method.** As far as possible, approach the obstacle straight, not from the side, and take off on one foot to cross the obstacle, while placing the right hand on top of the beam for support. The body weight is shifted entirely onto the right arm as the cadet moves over the obstacle with the right side facing it. The landing be made on one foot to maintain momentum. Only left hand should touch the beam, violation of which incurs a penalty in competitions including TSC.



- (c) **Common Faults.** Not maintaining enough momentum or stopping abruptly before crossing the obstacle, leading to injury.



### **HIGHER ORDER THINKING SKILLS (HOTS)**

- What is the aim of obstacle course training and how many obstacles are included in the Standard Obstacle Training?
- How does the obstacle course training contribute to the development of NCC cadets?

#### 11. **Ramp.**

(a) **Description.** The obstacle is a sloped hillock, measuring 15 feet in length, 18 feet in width, and 4.5 feet in height.

(b) **Method.** To cross it, the cadet runs up the slope to the top and takes a long jump, landing in the designated area, preferably on both feet. The knees have to be slightly bent to absorb the landing shock. The run-up should be steady and controlled, ensuring a smooth jump from the top and a balanced landing.



(c) **Common Faults.** Most injuries in this obstacle occur while landing. Major reason for the same is unsteady landing, especially on one foot, or landing without bending the knees even on both feet. Over weight participants are more at risk.

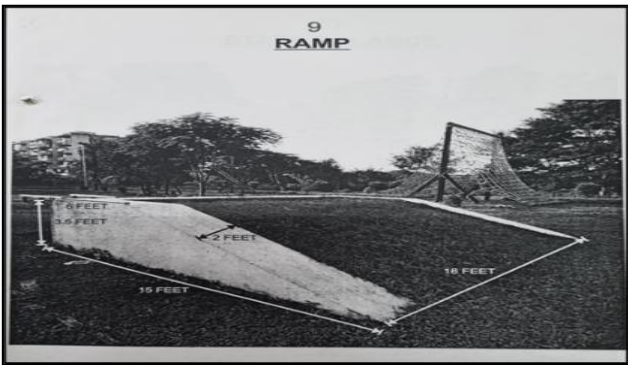

12. **Straight**

**Balance.**

(a) **Description.** Similar to the first Straight Balance obstacle.

(b) **Method:** To be approached as explained in first obstacle

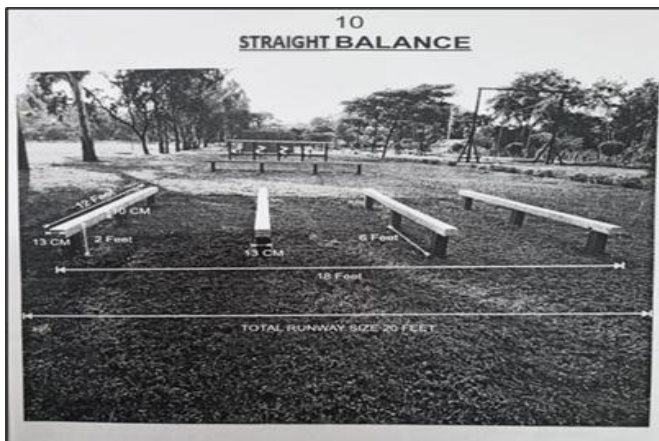

**PART II : DRESS & EQUIPMENT**

13. **Dress.** The training attire should progress through different stages. Initially, obstacle-negotiating techniques should be taught in tracksuits or **Single belt** for the first two sessions. Belt is advised to be worn even over tracksuits to maintain taut posture. **Even when wearing tracksuits, only DMS boots will be worn. The obstacle course should**



**not be done in PT shoes, sports shoes or Jungle boots, which may lead to severe injury.** By the third session, cadets should wear disruptive shirts, trousers, and boots. In the final stage of instruction, typically during the Standard Obstacle Course, the attire will be Battle Order less rifle.

14. **Obstacles for Senior Wing (SW) Cadets.** Senior Wing girl cadets are required to navigate the following obstacles:-

- (a) Straight Balance.
- (b) Clear Jump.
- (c) Gate Vault.
- (d) Zig-Zag Balance.
- (e) Ramp.
- (f) Straight Balance (Repeated).

### **PART III : METHODOLOGY OF NEGOTIATING THE OBSTACLE COURSE**

15. **Practice in Negotiating the Obstacle Course.** Regular practice is essential for mastering the skills needed to effectively navigate an obstacle course. Repeated exposure helps cadets build confidence, physical strength, agility, and mental resilience, all of which are key to overcoming various obstacles. During practice sessions, cadets should focus on improving their technique for each individual obstacle, such as jumps, vaults, balance beams, and climbing structures. Key aspects of successful obstacle course practice include:-

- (a) **Progressive Training.** Start with basic techniques, gradually moving to more complex challenges as cadets build strength and skill.
- (b) **Repetition for Muscle Memory.** Repeating each obstacle helps engrain proper technique, ensuring that movements become automatic and fluid during real-time challenges.
- (c) **Attention to Form.** Emphasis should be placed on proper posture, balance, and footwork to prevent injury and maximize efficiency.
- (d) **Developing Speed and Endurance.** As cadets gain proficiency, they should work on increasing their speed while maintaining control and precision. Endurance training is equally important for managing fatigue.
- (e) **Mental Preparation.** Tackling obstacles often requires quick decision-making and adaptability, so practice sessions should also focus on building mental toughness and focus. With consistent practice, cadets improve both their physical capabilities and the confidence needed to negotiate the obstacle course effectively.



16. **Safety Measures for Successful and Safe Completion of the Obstacle Course.**

- (a) **Participant Selection.** Only physically fit cadets should engage in obstacle course training.
- (b) **Progressive Training.** Begin training in single belt, gradually progressing to more advanced stages with packs and weapons.
- (c) **Warm up.** Proper warming up as per weather conditions is a must to practice safely and avoid injuries. Participants should only be allowed to enter the obstacle arena after having warmed up, which will include both running and stretching.
- (d) **Avoid Hazardous Conditions.** Steer clear of wet or slippery surfaces to minimize the risk of injury. Contact surface of the obstacles must be cleaned with dry cloth if it is suspected to be wet. Check the serviceability of the obstacles to ensure they do not give way in between practice.
- (e) **Qualified Supervision.** Obstacles should be attempted under the guidance of trained instructors to ensure proper technique and safety.
- (f) **First Aid Preparedness.** Ensure that first aid facilities are readily available for any injuries that may occur.

17. **Benefits of Obstacle Course Training.**

- (a) **Physical Fitness.** Improves overall strength, endurance, and cardiovascular health, making cadets physically robust.
- (b) **Agility.** Sharpens the ability to move swiftly and fluidly, essential in navigating dynamic environments.
- (c) **Mental Toughness.** Builds resilience and grit by pushing cadets to overcome difficult challenges.
- (d) **Coordination and Balance.** Enhances coordination between the mind and body, resulting in better balance and precision in movement.
- (e) **Risk-Taking Ability.** Encourages cadets to assess risks and face their fears, fostering confidence in decision-making.
- (f) **Problem-Solving Skills.** Teaches cadets to quickly analyze situations and make effective decisions under pressure.
- (g) **Team Spirit.** Strengthens collaboration and communication skills, fostering teamwork and unity among cadets.
- (h) **Developing Physical and Mental Fitness.** Builds both physical and mental endurance, essential for overcoming obstacles and challenges.
- (j) **Enhancing Leadership and Teamwork.** Instils leadership qualities and the importance of working as a cohesive team.
- (k) **Building Confidence and Self-Esteem.** Boosts self-confidence by successfully overcoming physical and mental challenges.



- (l) **Preparing for Real-Life Challenges.** Equips cadets with the skills to handle both physical and psychological challenges in life.
- (m) **Cultivating Discipline and Resilience.** Promotes discipline and resilience, essential qualities for personal and professional growth.
- (n) **Promoting Tactical Thinking.** Encourages strategic thinking and the ability to quickly devise solutions in complex situations.

18. **Demonstration.** Demonstrations will be conducted by trained cadets under the supervision of PI Staff. This live demonstration allows cadets to observe proper technique and safety practices before attempting the course themselves.

## **CONCLUSION**

19. Obstacle course training is a cornerstone of NCC's comprehensive physical fitness regimen. By teaching cadets how to navigate physical challenges, the training develops not just physical fitness but also critical mental and emotional traits like patience, courage, and determination. Intensive obstacle training, particularly during camps like the Thal Sainik Camp, builds the foundation for a well-rounded and confident individual, capable of tackling any challenge with poise and skill. The obstacle course training is more than a physical exercise; it is a test of mental robustness, teamwork, and personal courage.

## **SUMMARY**

- Obstacle training is a vital component of the NCC curriculum, designed to enhance cadets' physical fitness, mental resilience, and leadership skills. The training involves navigating a series of ten obstacles, such as the Straight Balance, High Wall, Double Ditch, and Zig-Zag Balance, each testing balance, agility, strength, and coordination.
- The primary objectives include building confidence, patience, and courage while improving agility, problem-solving abilities, and teamwork. Safety is a key focus, with cadets trained under supervision and proper techniques emphasized. The training fosters physical endurance, mental robustness, and a spirit of camaraderie.

**ASSESSMENT EXERCISE****Multiple Choice Questions**

- Q1. The Standard Obstacle Course that the NCC SW are required to cross consists of \_\_\_\_\_ obstacles?
- (a) 6 (b) 8  
(c) 10 (d) 12
- Q2. Clear Jump has a bar that is placed \_\_\_\_\_ above the ground?
- (a) 1 ft (b) 2 ft  
(c) 4 ft (d) 1.5 Ft
- Q3. The Standard height of High Wall obstacles is ?
- (a) 10ft (b) 8 ft  
(c) 6 ft (d) 12 ft
- Q4. Which of the following obstacle is optional for Girl cadet?
- (a) Straight Balance (b) Clear Jump  
(c) Zig Zag (d) High wall
- Q5. What is the purpose of obstacle course training for NCC cadets?
- (a) To enhance academic skills  
(b) To develop musical talents  
(c) To improve physical strength, confidence, courage, and willpower  
(d) To practice marksmanship
- Q6. How is the "Clear Jump" obstacle in the Standard Obstacle Course described?
- (a) Jumping over a wooden slab with open arms  
(b) Crossing a gate with parallel bars  
(c) Running over a Zig-Zag structure with open hands  
(d) Jumping over a straight bar without body contact



- Q7. Which obstacle involves jumping over a bricked wall with plaster on both sides?
- (a) Straight Balance (b) High Wall  
(c) Double Ditch (d) Ramp
- Q8. What safety measure is emphasized during the Obstacle Course training?
- (a) Selecting cadets randomly  
(b) Conducting training without any supervision  
(c) Avoiding wet and slippery obstacles  
(d) Ignoring the correct technique
- Q9. What benefit does obstacle course training provide according to the lesson?
- (a) Musical skills improvement (b) Flexibility and mental strength  
(c) Enhancing academic performance (d) Learning marksmanship
- Q10. In the "Left Hand Vault" obstacle, how does the cadet overcome it?
- (a) Jumping over using the right hand (b) Jumping over using both hands  
(c) Jumping over using the left hand (d) Crawling and climbing
- Q11. Where does intensive training for NCC cadets take place, especially in Thal Sainik Camps?
- (a) Obstacle Course centers (b) Regular classrooms  
(c) Music training camps (d) PT dress training camps
- Q12. According to the text, what qualities does obstacle course training aim to increase in NCC cadets?
- (a) Laziness and indifference (b) Agility, courage, patience, and confidence  
(c) Lack of teamwork (d) Fear and self-doubt
- Q13. What is the primary focus during the conduct of Obstacle Course training, according to safety measures?
- (a) Ignoring individual and team timings  
(b) Emphasizing individual timings only  
(c) Emphasizing team timings only  
(d) Ensuring suitable and physically fit cadets are selected



- Q14. How many obstacles does the Standard Obstacle Course consist of?
- (a) Five (b) Ten  
(c) Fifteen (d) Twenty
- Q15. What is the structure of the "Clear Jump" obstacle?
- (a) Zig-Zag like wooden bar (b) 6 feet high bricked wall  
(c) 18 ft long straight bar (d) Wooden slab above ground level
- Q16. How is the "High Wall" obstacle crossed?
- (a) Running and jumping over it (b) Crawling under it  
(c) Kicking the wall with both legs (d) Climbing over with hands and feet
- Q17. Which safety measure is emphasized during the conduct of Obstacle Course training?
- (a) Wet and slippery obstacles are encouraged  
(b) Training without supervision  
(c) Suitable and physically fit cadets only to be selected  
(d) Obstacles done without correct techniques
- Q18. What benefit does obstacle course training NOT provide?
- (a) Mental strength (b) Physical fitness  
(c) Artistic skills (d) Risk-taking ability
- Q19. Where is intensive training given to NCC cadets, especially in Thal Sainik Camps?
- (a) In regular classrooms (b) During outdoor sports events  
(c) In the obstacle course training area (d) In the camps, especially in Thal Sainik Camps
- Q20. What is one of the benefits of completing the Obstacle Course training?
- (a) Enhancing artistic skills (b) Improving risk-taking ability  
(c) Developing culinary expertise (d) Mastering computer programming



**SCHEMATIC LAYOUT OF STD OBST COURSE**  
 (Basic and Battle Physical Training Pamphlet No 5 Obstacle Training - 1970)

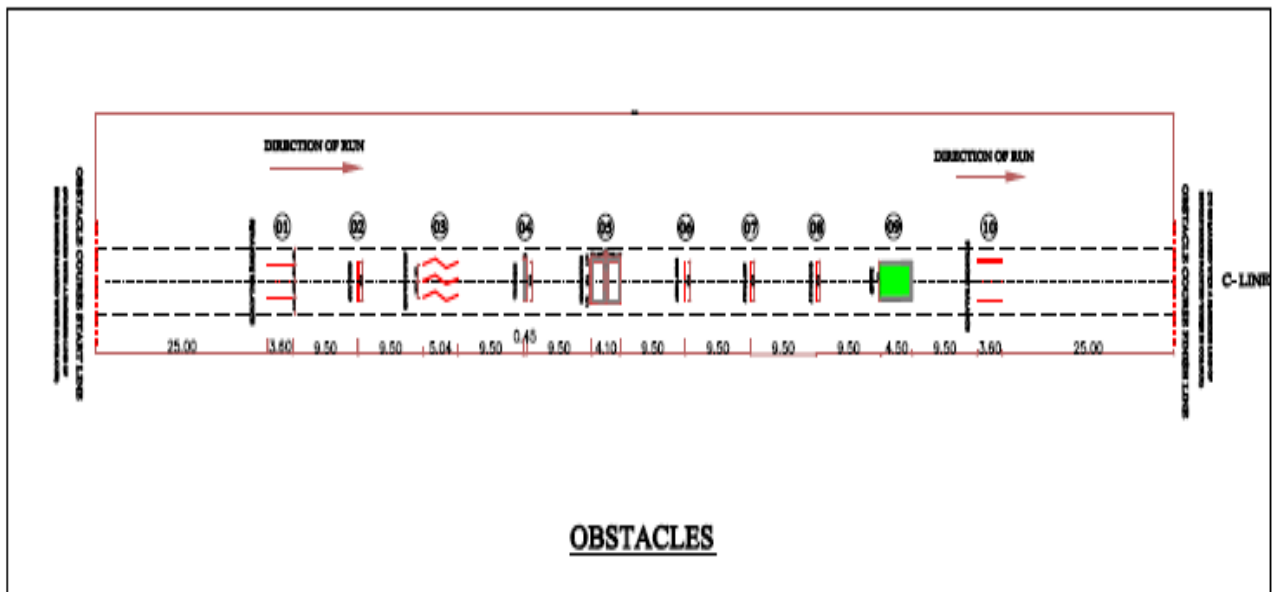
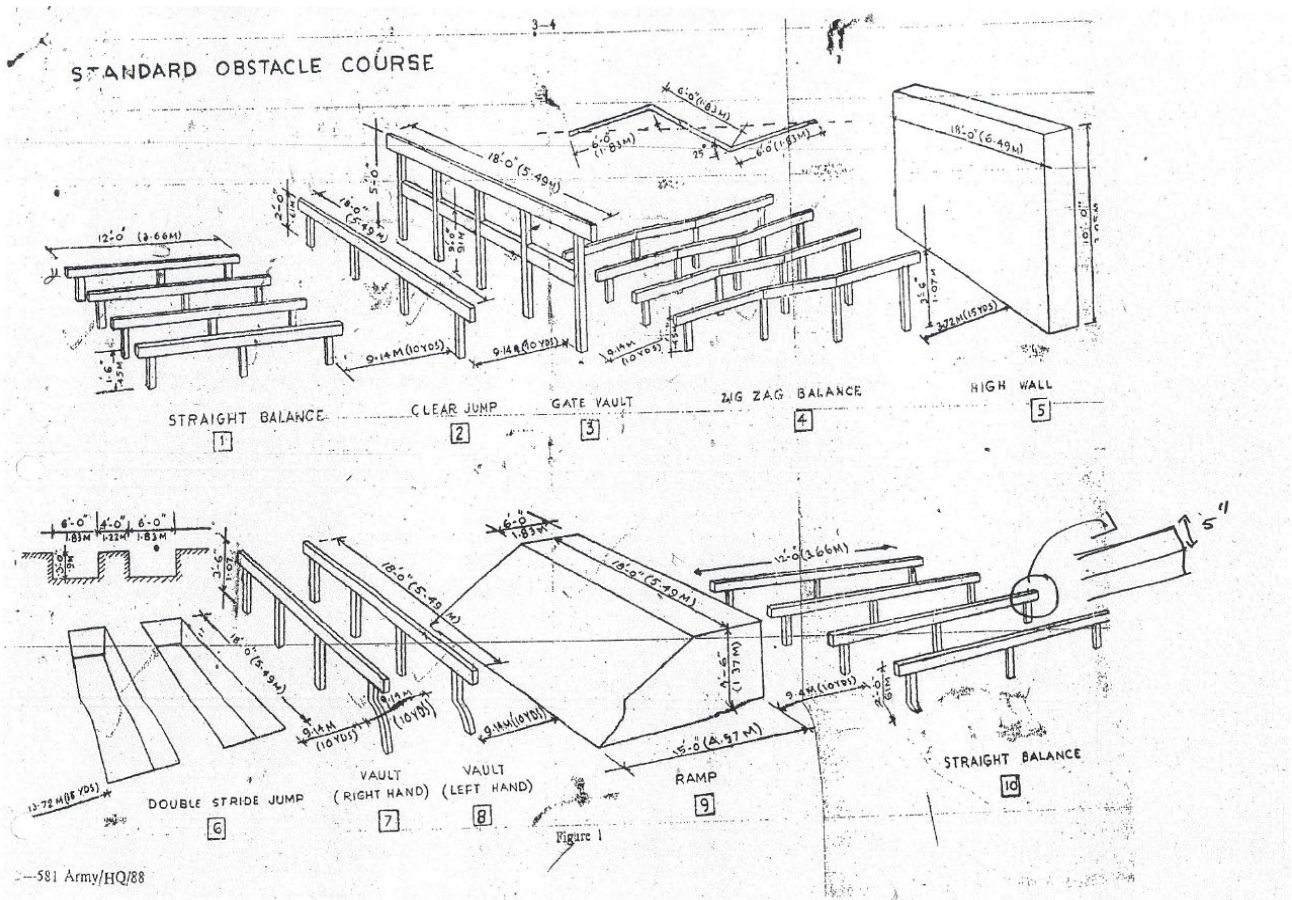

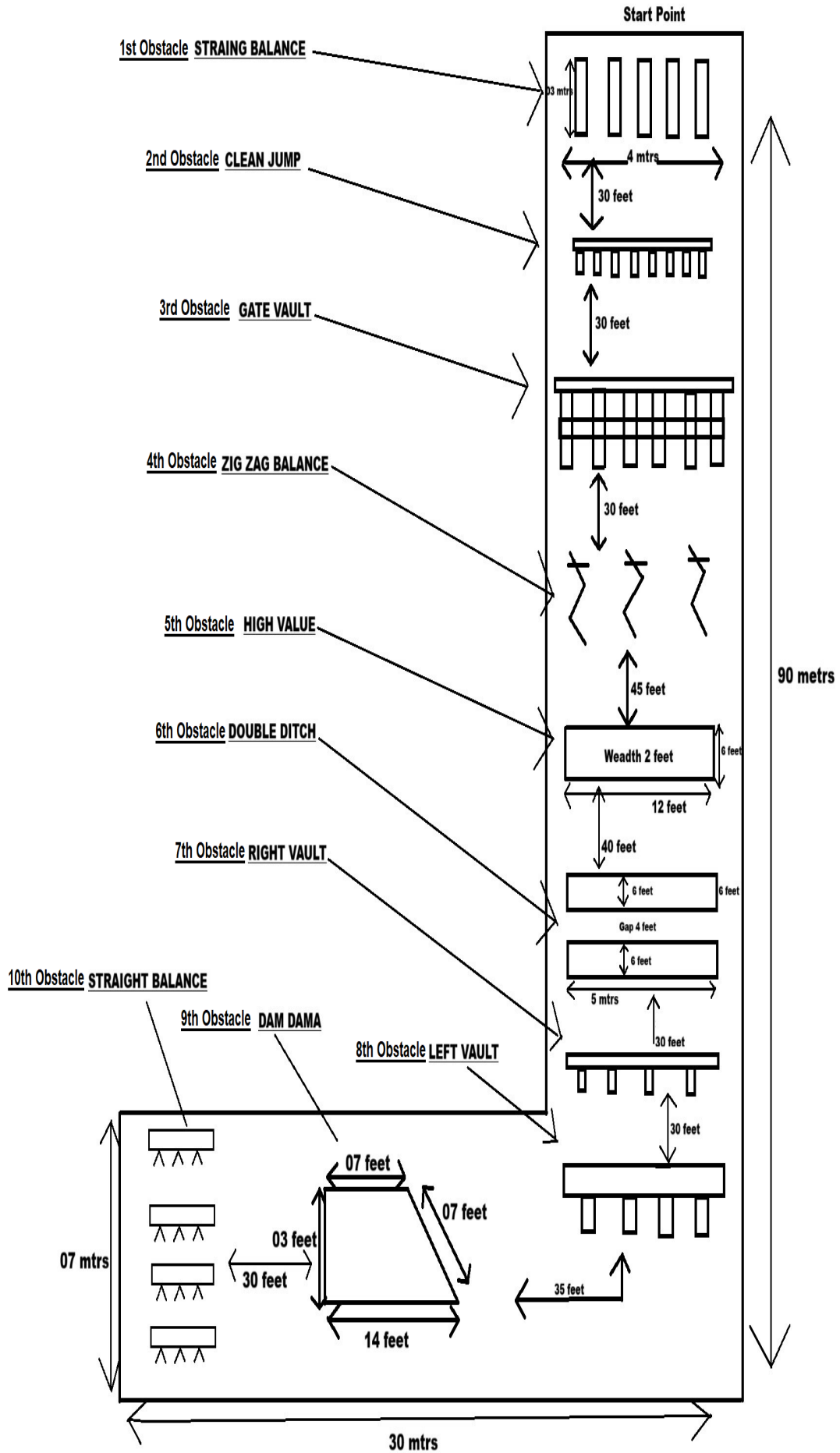



# DRONES



### CHAPTER WISE INDEX - DRONES (SD/SW)

<b>Ser No</b>	<b>Subject</b>	<b>Page</b>
1.	Chapter I : Evolution and Types of Drones	203
2.	Chapter I : Basic Principles of Flight	217
3.	Chapter I : DGCA Rules on Drones	230
4.	Chapter I : Application of Drones	242
5.	Chapter I : Drone Operations	259



## DRONES

### CHAPTER D I : EVOLUTION AND TYPES OF DRONES

*“A drone, in technological terms, is an unmanned aircraft. ... Essentially, a drone is a flying robot that can be remotely controlled or fly autonomously through software-controlled flight plans in their embedded systems, working in conjunction with onboard sensors and GPS”*



### TEACHING INSTRUCTIONS

<b>Period</b>	:	One (01)
<b>Type</b>	:	Lecture and Presentation
<b>Year</b>	:	1st Year SD/SW
<b>Conducting Officer</b>	:	Officer/ Trained PI/ AMI/ CGI
<b><u>Training Aids</u></b>	:	Class Room, Computer with OHP, Screen, Pointer Staff, Presentation, Script or Book Flagged or Lesson Plan in File, Board and Markers, and Models.

#### Time Plan

➤ Introduction	:	05 Min
➤ History of Drones	:	10 Min
➤ Classification of Drones	:	20 Min
➤ Conclusion	:	05 Min



## INTRODUCTION

1. A drone, in technological terms, is an unmanned aircraft. Essentially, its a flying robot that can be remotely controlled or fly autonomously through software-controlled flight plans in their embedded systems, working in conjunction with on-board sensors and GPS. Drones can be rightly termed as “eye in the sky”.
2. Drones have revolutionized various industries by providing a versatile platform for a wide range of applications. These aircrafts are equipped with advanced technologies, such as high-resolution cameras, thermal sensors, and precise navigation systems, allowing them to perform tasks like aerial photography, surveillance, mapping, and search-and-rescue operations.

### PREVIEW

The lecture will be conducted in the following parts:-

- Part I : Evolution of Drones
- Part II : Classification of Drones

### LEARNING OBJECTIVES

- To understand the history and evolution of drones
- To learn and understand the categorisation of unmanned aircraft systems.
- Understanding the classification of unmanned aircraft systems

## PART I: EVOLUTION OF DRONES

3. **Early Beginnings.** The genesis and history of drones is a fascinating journey that spans centuries, evolving from early concepts to the advanced technology we see today.
  - (a) **Ancient China.** The earliest use of unmanned flying devices can be traced back to ancient China, where kites were used for signaling, reconnaissance, and even lifting soldiers into the air.
  - (b) **Leonardo da Vinci.** In the late 15th century, da Vinci envisioned machines resembling birds and bats, capable of flight without a pilot.
4. **Military Roots.**
  - (a) **World War I.** The British military developed the "Aerial Target" to distract and confuse enemy defenses.
  - (b) **World War II.** Both the US and Germany made significant strides in drone technology. The US developed the "Radioplane OQ-2" for target practice, while Germany created the "V-1" flying bomb.

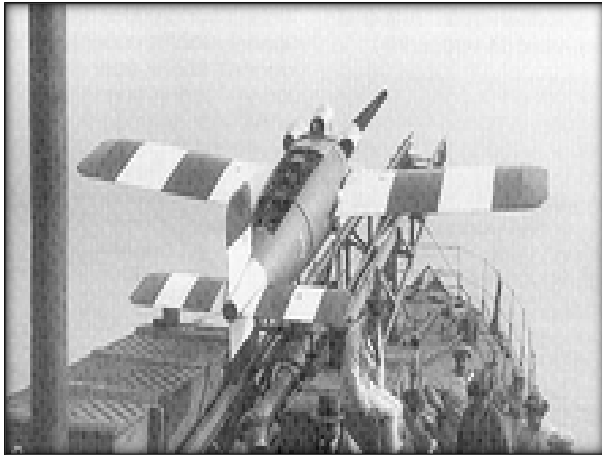

## 5. Post-War Developments.

- (a) **1960s**. The US military began experimenting with remotely piloted aircraft for reconnaissance, leading to the development of the "Ryan Firebee".
- (b) **1980s-1990s**. Drones started to be used for scientific research, environmental monitoring, and even entertainment.

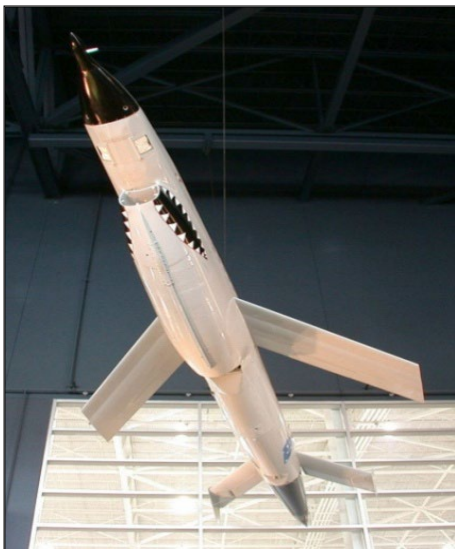

## 6. Modern Era.

- (a) **2000s**. The advent of GPS and advanced sensors led to significant advancements in drone technology.
- (b) **2010 to Present Era**. Drones have become indispensable tools in various fields, including agriculture, delivery services, infrastructure inspection, emergency response and even a medium to attack enemy country through aerial route.

7. **Key Milestones**. Drones have come a long way from their early military origins to becoming versatile tools used in everyday life. Their evolution continues as technology advances, opening up new possibilities and applications. Some important milestones are as under:-



- (a) **1849.** Austrian soldiers attacked the city of Venice with unmanned balloons filled with explosives.
- (b) **1917.** The British "Aerial Target" was the first successful remote-controlled aircraft.
- (c) **1935.** Reginald Denny developed the first civilian remotely piloted vehicle.
- (d) **1960s.** The "Ryan Firebee" became one of the first successful remotely piloted drones.

8. Drones have come a long way from their early military origins to becoming versatile tools used in everyday life. Their evolution continues as technology advances, opening up new possibilities and applications.

### **Glossary of Terms.**

9. **Drone.** It means an unmanned aircraft system which can be remotely controlled or fly autonomously through software-controlled flight plans in their embedded systems, working in conjunction with on-board sensors and GPS.

10. **Drone Acknowledgement Number.** It denotes the unique number issued by the digital sky platform under the voluntary disclosure scheme for unmanned aircraft systems in India.

11. **Geo-fencing.** It means restricting the movement of unmanned aircraft system within a defined airspace.

12. **Digital Sky Platform.** It refers to the online platform hosted by the Directorate General of Civil Aviation for various activities related to the management of unmanned aircraft system activities in India.

### **INTERESTING FACT**

- The global drone market size was estimated at USD 64.32 billion in 2023 and is projected to grow at a Compounded annual growth rate of 14.5% from 2024 to 2030, owing to various factors, such as advances in technology, broadening application portfolio across various industries, and plummeting costs of drone technology

### **HIGHER ORDER THINKING SKILLS (HOTS)**

- **Historical Impact.** Analyse the historical events that led to the development of drone technology. How did the needs and innovations of wartime contribute to the evolution of drones?
- **Technological Evolution.** Examine the key technological advancements that made the early development of drones possible. How did breakthroughs in radio control and material science play a role?
- **Comparative Analysis.** Compare the initial uses of drones in military contexts to their modern-day applications. How have the core principles remained the same or evolved over time?

### 13. Interesting Timelines.



**Winston Churchill, David Margesson and others wait to watch the launch of de Havilland Queen Bee target drone, 06 June 1941.**

**US Army commissioned the Kettering Aerial Torpedo - the "Bug".**

**The "Bug" after a predetermined length go time, an electrical circuit used to shut off the engine and the wings were released, causing the "Bug" to plunge to earth - where its 180 lbs of explosive detonated on impact.**



**The next phase went from the swamps of Vietnam, to the remote hills and caves of Pakistan and Afghanistan.**

**The Predator air vehicle is 8.2m (27ft) long and has a 14.9m (49ft) wingspan. The system operates at an altitude of 7,620m (25,000ft) and has a range of around 740 Km.**

***“The drone revolution will change the way we live, work, and play.” - Chris Anderson***



## **PART II : CLASSIFICATION OF DRONES**

14. Drones come in various types, each designed for specific applications and functions. They are categorized and classified in several ways.

### **Based on Design**

15. **Multicopter Drones.**

- (a) **Quadcopters.** Four rotors, used for aerial photography, surveillance, and recreational purposes.
- (b) **Hexacopters.** Six rotors, offering more stability and payload capacity.
- (c) **Octocopters.** Eight rotors, used for heavy-lift operations and high-end cinematography.

16. **Fixed-Wing Drones.**

- (a) Similar to traditional aeroplanes, used for long-distance missions and high-endurance tasks.
- (b) Commonly used in mapping, surveying, and agricultural monitoring.

17. **Hybrid VTOL Drones.**

- (a) Capable of Vertical Take-off and Landing (VTOL) and efficient forward flight.
- (b) Combine features of both multicopter and fixed-wing drones.

### **By Operational Use**

18. **Model Remotely Piloted Aircraft System (MRPAS).** Used for educational and research purposes without payload.

19. **Remotely Piloted Aircraft System (RPAS).** Piloted from a remote pilot station for various purposes, including surveillance and deliveries.

20. **Autonomous Unmanned Aircraft System (AUAS).** Operates autonomously without pilot intervention, often used in complex missions.

### **Based on Size and Weight**

21. **The Unmanned Aircraft System (UAS).** Based on the maximum all-up weight including payload, is classified as given in succeeding paragraphs.

22. **Nano UAS.** Very small, often used for indoor flight and educational purposes, weighing less than or equal to 250 grams.

23. **Micro UAS.** Slightly larger than Nano drones, used for hobbyist activities and short-range surveillance, weighing more than 250 grams, but less than or equal to 2 kg.



24. **Small UAS.** Compact drones for consumer use, often used for photography and racing, weighing more than 2 kg but less than or equal to 25 kg.
25. **Medium UAS.** Used in commercial applications such as delivery and industrial inspections, weighing more than 25 kg, but less than or equal to 150 kg.
26. **Large UAS.** Heavy-duty drones used in military, cargo transport, and long-endurance surveillance missions, weighing more than 150 kg.

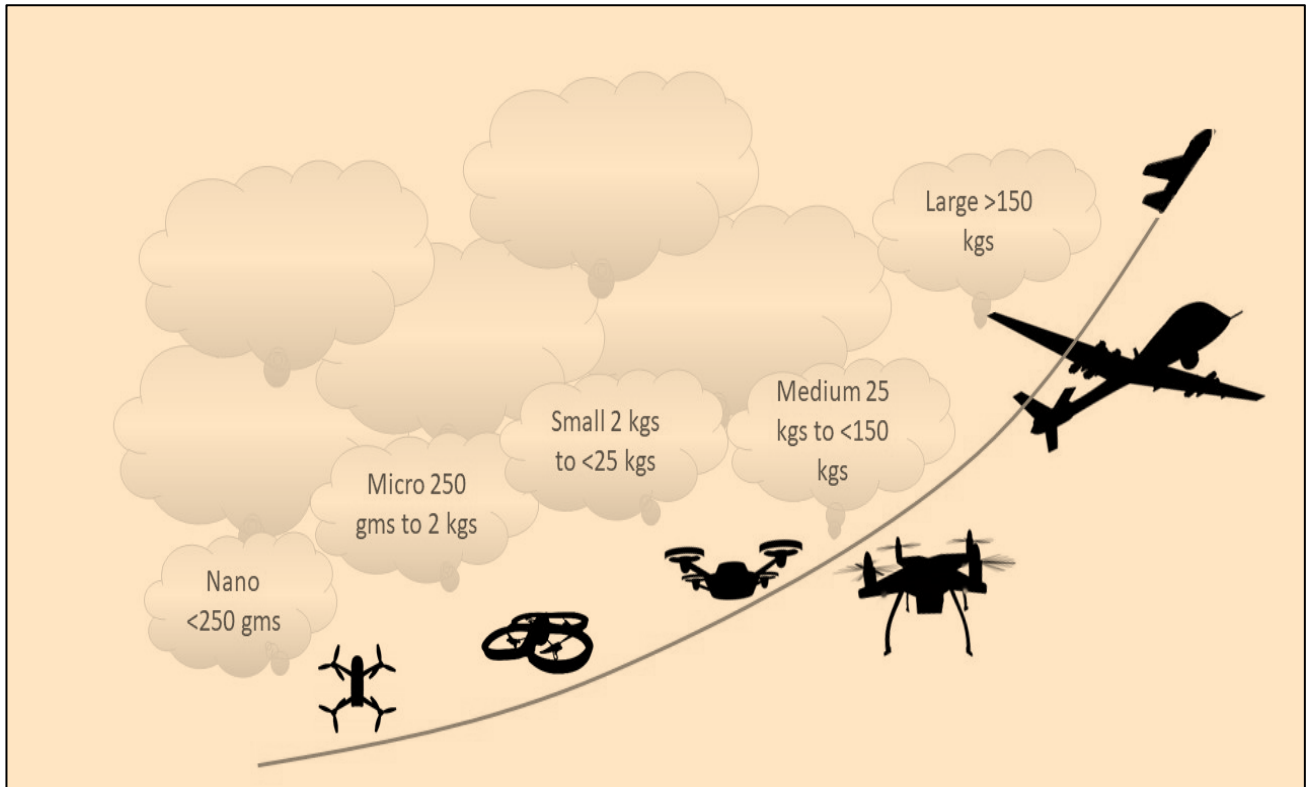

### **Based on Usage**

27. **Commercial Drones.** Used in agriculture, delivery services, infrastructure inspection, and filmmaking.
28. **Military Drones.** Used for reconnaissance, combat operations, and surveillance.
29. **Recreational Drones.** Used by hobbyists for fun, aerial photography, and racing.
30. **Industrial Drones.** Used in construction, mining, and energy sectors for inspection and monitoring.
31. **Scientific Drones.** Used in research, environmental monitoring, and wildlife tracking.

### **Scope of Drone Operations**

32. These categories are critical in understanding the scope and limitations of drone operations, influencing both technological development and regulatory frameworks. An overview of **VLOS (Visual Line of Sight)** and **BVLOS (Beyond Visual Line of Sight)** in drone operations is given in succeeding paragraphs.



### 33. **Visual Line of Sight (VLOS).**

- (a) **Definition.** The drone is always flown within the pilot's visual line of sight.
- (b) **Visibility.** The pilot must be able to see the drone without any visual aids (e.g., binoculars or FPV goggles).
- (c) **Safety.** The pilot can monitor the airspace for potential hazards and maintain control of the drone.
- (d) **Distance.** Typically, the maximum visibility is around 500 meters (1640 feet), but this can vary based on factors like drone size, environment, and weather conditions.

### 34. **Beyond Visual Line of Sight (BVLOS).**

- (a) **Definition.** The drone is flown beyond the pilot's visual line of sight.
- (b) **Visibility.** The pilot does not have direct visual contact with the drone.
- (c) **Safety.** Requires advanced planning, reliable communication systems, and often additional safety measures.
- (d) **Applications.** Used for long-range missions, such as infrastructure inspection, delivery services, and large-scale agricultural monitoring.

### 35. **Key Differences.**

- (a) **Control.** In VLOS, the pilot directly controls the drone. In BVLOS, the drone may operate autonomously or with remote control.
- (b) **Regulations.** BVLOS operations typically require special permissions and certifications due to the increased complexity and safety considerations.

36. BVLOS operations hold great potential for expanding the capabilities of drones, but they also come with additional challenges and regulatory requirements.

#### **HIGHER ORDER THINKING SKILLS (HOTS)**

- **Interdisciplinary Integration.** Explore how the different fields of science and engineering contributed to the initial development of drones. What interdisciplinary collaborations were crucial to early drone innovation?
- **Technological Challenges.** Identify the primary challenges faced during the early development of drones. How were the challenges overcome, and what lessons were learnt that apply to current drone technology?
- **Predictive Analysis.** Based on the historical development of drones, predict the future trends in drone technology. How might the foundational principles of early drones influence future innovations?
- **Global Influence.** Assess the global influence of early drone technology on international military strategy and policy. How did the development of drones global dynamics and power structures?



## CONCLUSION

37. Drones, once a futuristic concept, have rapidly evolved into versatile tools with a wide range of applications. From their humble beginnings as military targets to their current role in various industries, drones have transformed the way we perceive and interact with the world.

38. **Key Takeaways from the Evolution of Drones.**

(a) **Technological Advancements.** The integration of GPS, advanced sensors, and autonomous flight capabilities has significantly enhanced drone performance and functionality.

(b) **Diverse Applications.** Drones are used in sectors such as agriculture, logistics, construction, and entertainment, offering innovative solutions to complex challenges.

(c) **Regulatory Framework.** The development of comprehensive regulations is crucial to ensure the safe and responsible use of drones.

(d) **Future Potential.** As technology continues to advance, drones are poised to revolutionize industries and redefine the possibilities of aerial operations.

39. By understanding the history, types, and applications of drones, we can appreciate their transformative impact and anticipate their future potential.

## SUMMARY

- The concept of drones dates back to 1849.
- 1915-1920 saw a giant leap forward in drone technology.
- The first pilotless aircraft was developed in 1916.
- In the 1930s, the U.S. Navy began experimenting with radio-controlled aircraft.
- “Drone Acknowledgement Number” means the unique number issued by the digital sky platform.
- “Digital Sky Platform” means the online platform hosted by the DGCA.
- The UAS is categorised as Aeroplane, Rotorcraft and Hybrid.
- UAS is based on the maximum all-up weight.
- **Multicopter Drones.** Quadcopters, Hexacopter, Octocopters.
- **Fixed-Wing Drones.** Airplane-like drones.



- **Hybrid VTOL Drones**. Combines multirotor and fixed-wing features.
- **MRPAS**. Model Remotely Piloted Aircraft System
- **RPAS**. Remotely Piloted Aircraft System
- **AUAS**. Autonomous Unmanned Aircraft System
- **VLOS (Visual Line of Sight)**. Pilot maintains visual contact.
- **BVLOS (Beyond Visual Line of Sight)**. Drone operates autonomously or with remote control.



## **ASSESSMENT EXERCISE**

### **Multiple Choice Questions**

- Q1. What does the term "Drone" refer to?
- (a) A manned aircraft system
  - (b) A remote control vehicle
  - (c) An unmanned aircraft system
  - (d) A satellite-based communication system
- Q2. What is a "Drone acknowledgement number"?
- (a) The registration number issued for manned aircrafts
  - (b) The unique number issued by the digital sky platform for unmanned aircraft systems
  - (c) A tracking number for drone deliveries
  - (d) A pilot's certification number
- Q3. Which of the following is NOT a person subject to the Drone Rules?
- (a) A person owning a drone
  - (b) A person operating a drone in India
  - (c) A person selling manned aircraft
  - (d) A person maintaining a drone
- Q4. To which unmanned aircraft systems do the Aircraft Rules, 1937 still apply?
- (a) Drones used by private companies
  - (b) Unmanned aircraft systems with a maximum all-up-weight of more than 500 kilograms
  - (c) All drones regardless of weight
  - (d) Drones operated for research purposes
- Q5. Which entity operates the "Digital Sky Platform"?
- (a) The Indian Navy
  - (b) The Ministry of Communications
  - (c) The Directorate General of Civil Aviation
  - (d) The Indian Meteorological Department



Q6. What is the primary characteristic of an "Aeroplane" in the context of unmanned aircraft systems?

- (a) It is a lighter-than-air aircraft.
- (b) It derives lift from fixed aerodynamic surfaces.
- (c) It uses rotors for lift during flight.
- (d) It relies on engine thrust only for lift.

Q7. How is a "Rotorcraft" supported in flight?

- (a) By a fixed-wing surface
- (b) By the reactions of air on one or more power-driven rotors on vertical axes.
- (c) By gliding on air currents.
- (d) By a combination of fixed-wing and rotor-based mechanisms.

Q8. Which of the following best describes a "Hybrid Unmanned Aircraft System"?

- (a) It relies on fixed surfaces for vertical and horizontal flight.
- (b) It is supported by rotating airfoils during vertical flight only.
- (c) It is capable of vertical take-off and uses non-rotating airfoils during horizontal flight.
- (d) It has no capability for vertical take-off and landing.

Q9. Which of the following is NOT a sub-category of unmanned aircraft systems?

- (a) Remotely piloted aircraft system
- (b) Autonomous unmanned aircraft system
- (c) Semi-autonomous manned aircraft system
- (d) Model remotely piloted aircraft system

Q10. What is the maximum weight limit for a Nano UAS?

- (a) 250 grams
- (b) 2 kilograms
- (c) 25 kilograms
- (d) 150 kilograms

Q11. Which classification includes unmanned aircraft weighing more than 250 grams but less than or equal to 2 kilograms?

- (a) Nano UAS
- (b) Micro UAS
- (c) Small UAS
- (d) Medium UAS



Q12. Which classification applies to unmanned aircraft weighing more than 25 kilograms but less than or equal to 150 kilograms?

- (a) Nano UAS
- (b) Small UAS
- (c) Medium UAS
- (d) Large UAS

Q13. Which category of unmanned aircraft includes vehicles weighing more than 150 kilograms?

- (a) Small UAS
- (b) Medium UAS
- (c) Large UAS
- (d) Micro UAS

Q14. What is the primary function of a "Remotely piloted aircraft system"?

- (a) It operates autonomously with no human intervention.
- (b) It is controlled by a human operator using a remote system.
- (c) It is used for recreational purposes only.
- (d) It is controlled by on-board pilots.

Q15. Which of the following unmanned aircraft systems can perform vertical take-off and landing?

- (a) Aeroplane
- (b) Rotorcraft
- (c) Hybrid unmanned aircraft system
- (d) Nano UAS

### **Fill in the Blanks**

Q1. The \_\_\_\_\_ is an online platform for managing unmanned aircraft systems activities in India.

Q2. The \_\_\_\_\_ Rules, 1937 do not apply to unmanned aircraft systems except those with a maximum all-up-weight of more than 500 kilograms.

Q3. An unmanned aircraft system used by the naval, military, or air forces of India is \_\_\_\_\_ from the Drone Rules.

Q4. A "Drone acknowledgement number" is issued by the \_\_\_\_\_ under the voluntary disclosure scheme.



Q5. The Drone Rules apply to all unmanned aircraft systems that are being operated in or over \_\_\_\_\_.

### **Short Answer Questions**

- Q1. Which year saw the development of the first pilotless aircraft?
- Q2. Which organisation experimented with radio-controlled aircraft in the 1930s?
- Q3. What does the term "Drone Acknowledgement Number" refer to?
- Q4. What is the "Digital Sky Platform"?
- Q5. How are UAS categorised based on their maximum all-up weight?
- Q6. Name three types of multirotor drones.
- Q7. What type of drones are similar to traditional aeroplanes?

### **Long Answer Questions**

- Q1. Discuss the evolution of drone technology from its inception in 1849 to the early 20th century.
- Q2. Explain the significance of the development of the first pilotless aircraft in 1916 and its impact on subsequent drone technology.
- Q3. Analyse the role and importance of the Digital Sky Platform and the Drone Acknowledgement Number in the regulation of drone operations in India.
- Q4. Compare and contrast the different types of UAS categorised by their design and operational use, including aeroplanes, rotorcraft, and hybrids.
- Q5. What does VLOS stand for in drone operations? Describe how VLOS systems operate.

## DRONES

### CHAPTER D II : BASIC PRINCIPLES OF FLIGHT

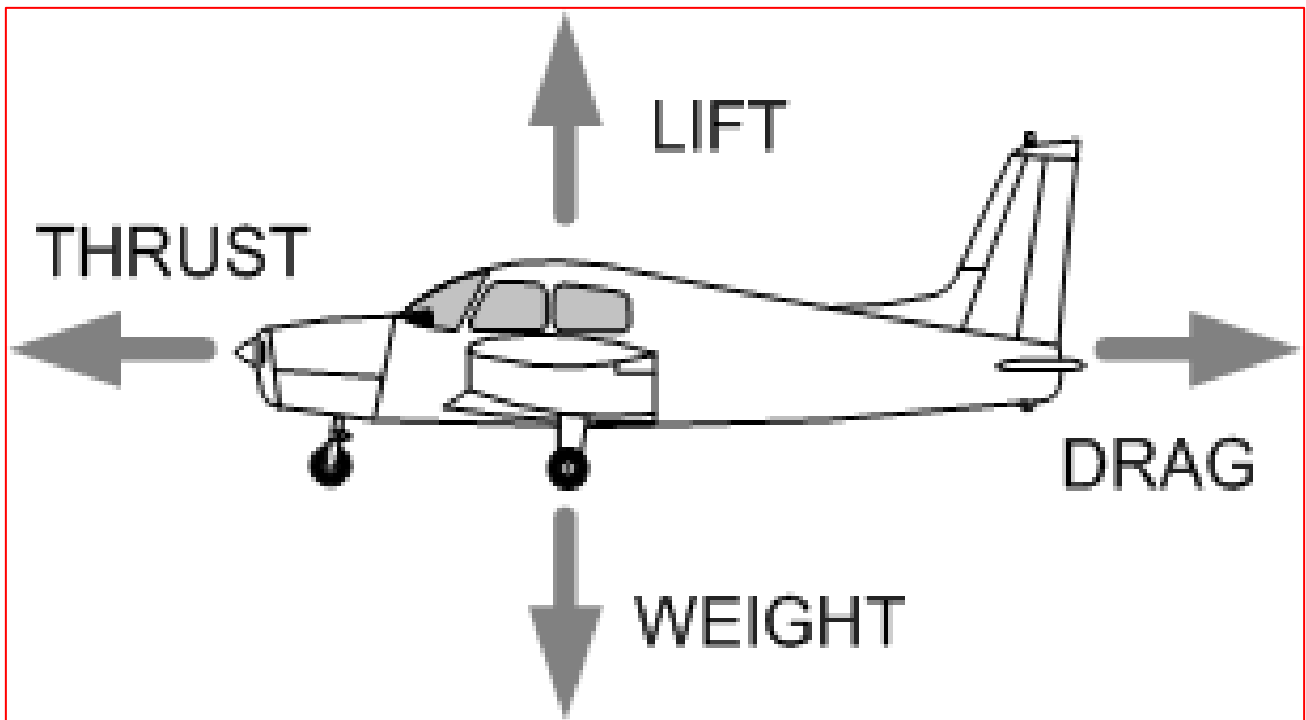

### TEACHING INSTRUCTIONS

<b>Period</b>	:	Two (02)
<b>Type</b>	:	Lecture and Presentation
<b>Year</b>	:	2nd Year SD/SW
<b>Conducting Officer</b>	:	Officer/ Trained PI/AMI/CGI
<b><u>Training Aids</u></b>	:	Class Room, Computer with OHP, Screen, Pointer Staff, Presentation, Script or Book Flagged or Lesson Plan in File, Board and Markers, and Models.

#### Time Plan

➤ Introduction	:	05 min
➤ Fundamentals of Flight	:	20 min
➤ Control Surfaces of an Aircraft	:	15 min
➤ Flight Proper	:	20 min
➤ Manoeuvres, Phases and Circuit Pattern	:	10 min
➤ Q & A Session & Conclusion	:	10 min



## INTRODUCTION

1. Aerodynamics plays a crucial role in designing aircraft to maximise efficiency and safety. Understanding how air interacts with the aircraft's surfaces helps engineers improve performance and stability. These principles are fundamental to the science of aviation, ensuring that aircraft can fly safely and efficiently through the balance of these forces and controls.

2. The basic principles of flight for drones are similar to those of fixed-wing and rotary, aircrafts but they are more specialized due to their unique design and technology. To stay in the air, like aircrafts, drones also rely on four main forces of **lift**, **weight**, **thrust**, and **drag**. Drone technology is woven around the interplay of these forces.

### PREVIEW

The lecture will be conducted in the following parts:-

- Part I : Fundamentals of Flight
- Part II : Takeoff, Flight, and Landings
- Part III : Manoeuvres and Turns

### LEARNING OBJECTIVES

- To understand the basic principle of flight.
- To learn about primary controls & movements.
- Understanding the aircraft manoeuvres and circuit pattern.

## PART I : FUNDAMENTALS OF FLIGHT

### Glossary of Terms

3. **Airfoil.** An **Airfoil** is a streamlined shape designed to produce more lift than drag when moving through a fluid.

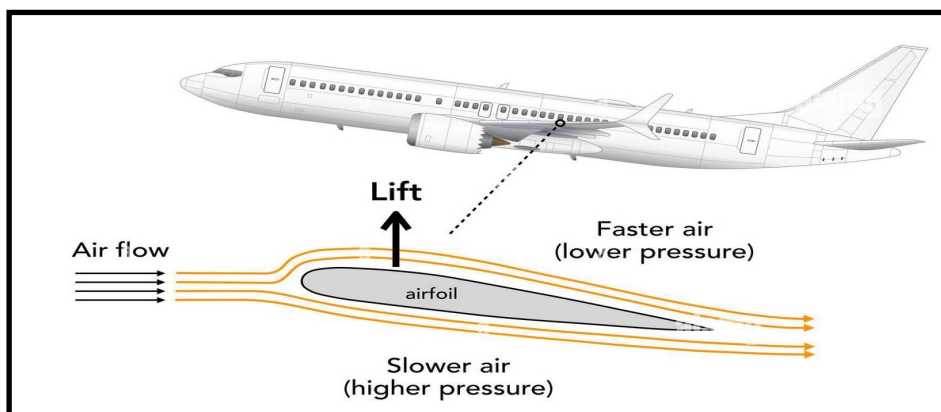



4. **Chord Line**. It is a line joining the centres of curvature of leading and trailing edges of an airfoil section.

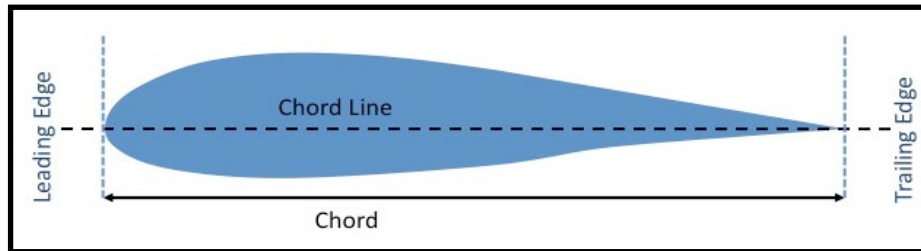

5. **Angle of Attack (AoA)**. It is an angle between the chord line of the airfoil and the relative airflow.

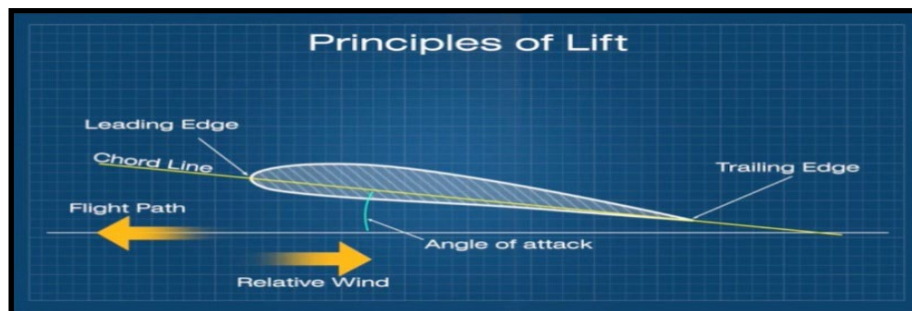

6. **Angle of Incidence**. The angle between the chord line and the longitudinal axis of the aircraft is called Angle of Incidence.

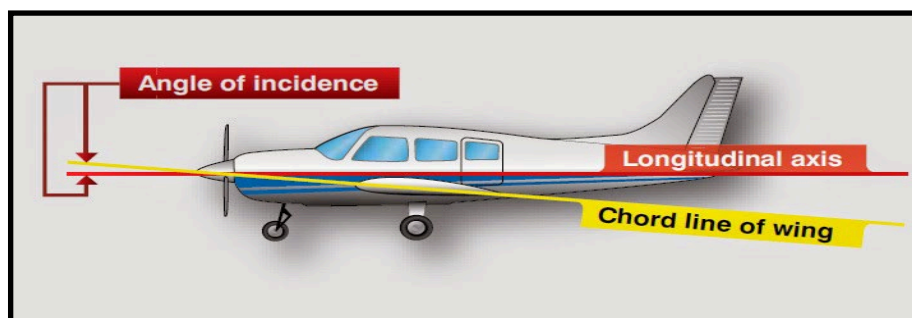

### **Aerodynamic Principles**

7. The aerodynamic principles of flight form the foundation of how objects like airplanes, helicopters, and drones achieve and maintain flight.

### **Forces Acting on an Aircraft**

8. The aerodynamic principles revolve around four key forces which are lift, drag, thrust and weight. These forces all interact together to determine an aeroplane's trajectory. Lift and weight are opposing forces, as are thrust and drag. All are equally important and must be balanced to maintain level flight.

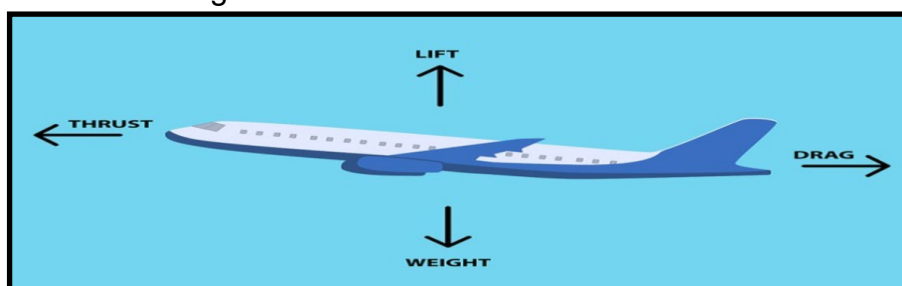



(a) **Weight.** Weight is the force of gravity pulling the object downward toward the Earth. Weight is proportional to the mass of the object and acts through its center of gravity. In flight, the force of weight is countered by the forces of lift and thrust.

(b) **Lift.** Lift is the upward force that opposes the downward pull of gravity or weight. It is a positive force generated by the movement of air over an airfoil e.g., wings or propellers because of the difference in air pressure under and above a wing. The higher air pressure beneath a wing creates lift. Volume of lift generated is affected by the shape of the wing. **To achieve flight, lift must equal or exceed weight.**

(c) **Thrust.** Thrust is the **forward force** that propels an object through the air. Thrust is typically generated by engines, propellers, or jet turbines, through some kind of propulsion system. For drones, the spinning rotors create thrust by pushing air downward and forward, propelling the drone.

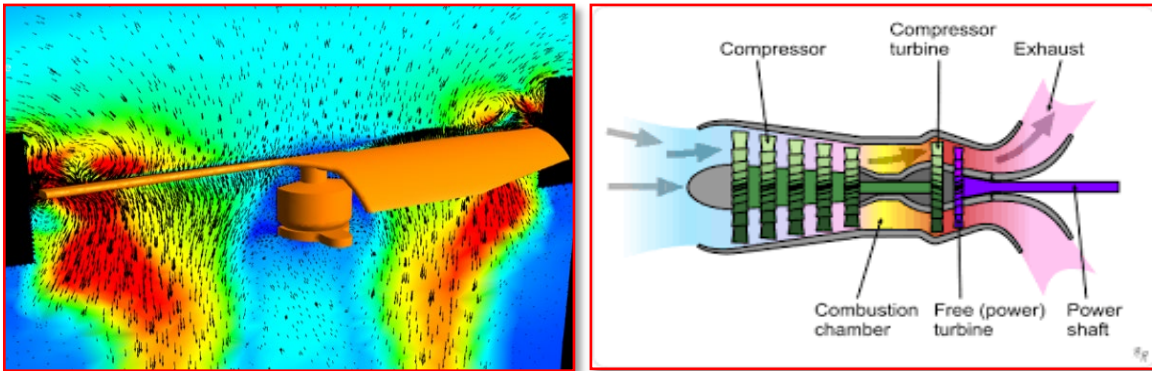

(d) **Drag** is the resistance of the air to anything moving through it. Drag is the opposing force to thrust. It is caused by aerodynamic resistance as an object moves through the air. Drag is an umbrella term which can include form drag, parasite drag etc.

(e) The four forces making up the principle of flight are **lift, weight, drag, and thrust**. The forces all interact together to determine an airplane's trajectory. Lift and weight are opposing forces, as are thrust and drag. All are equally important, and they must be balanced to maintain a level flight.

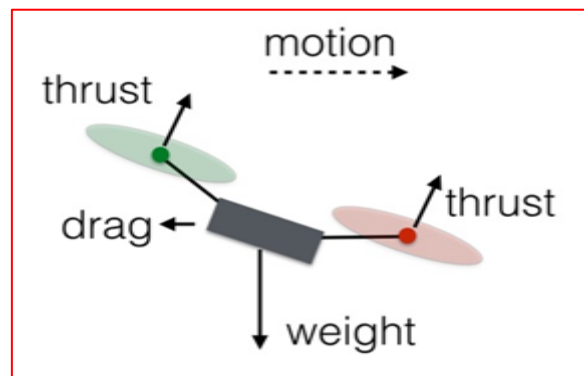



## PART II : CONTROL SURFACES AND AXIS OF AN AIRCRAFT

9. The control surfaces work in conjunction with the aircraft's axis of rotation to provide precise control over its flight path. By understanding these fundamental principles, pilots can safely and efficiently manoeuvre their aircraft. An aircraft's ability to manoeuvre in three dimensions is made possible by its control surfaces and axis of rotation. These elements work in tandem to allow pilots to precisely control the aircraft's flight path.

### 10. Control Surfaces.

(a) **Ailerons.** These are hinged sections on the trailing edge of each wing. By deflecting the ailerons differentially, the pilot can create a difference in lift between the wings, causing the aircraft to roll.

(b) **Elevators.** These are hinged sections on the trailing edge of the horizontal stabilizer. By deflecting the elevators up or down, the pilot can control the pitch of the aircraft.

(c) **Rudder.** The rudder is a hinged section on the trailing edge of the vertical stabilizer. By deflecting the rudder left or right, the pilot can control the yaw of the aircraft.

### 11. Axis of Rotation.

(a) **Lateral Axis (Roll).** This axis runs from wingtip to wingtip. Rolling the aircraft involves tilting its wings left or right.

(b) **Longitudinal Axis (Pitch).** This axis runs from the nose to the tail of the aircraft. Pitching involves raising or lowering the nose of the aircraft.

(c) **Vertical Axis (Yaw).** This axis runs vertically through the aircraft's center of gravity. Yawing involves turning the nose of the aircraft left or right.

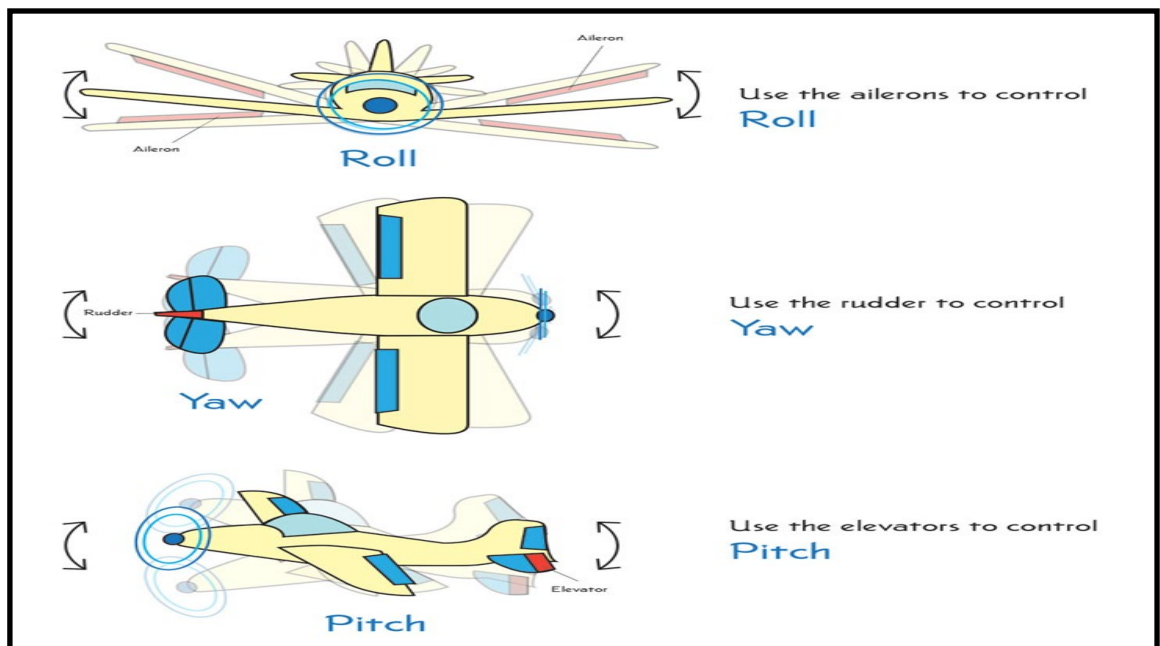



### PART III : FLIGHT PROPER

12. Importance of Angle of Attack in Flight. As mentioned in glossary, Angle of Attack is the angle between the chord line of an airfoil and the relative airflow. Increasing the angle of attack increases lift up to a certain point. If the angle becomes too steep (called Critical Angle of Attack), airflow separates from the airfoil's surface, causing a stall (a sudden loss of lift). Pilots adjust the angle of attack to control lift during takeoff, cruising, and landing.

#### How Wings Lift an Aeroplane or a Fixed Wing Drone.

13. Aeroplane wings are shaped to make air move faster over the top of the wing. When air moves faster, the pressure of the air decreases. So, the pressure on the top of the wing is less than the pressure on the bottom of the wing. The difference in pressure creates a force on the wing that lifts the wing up into the air.

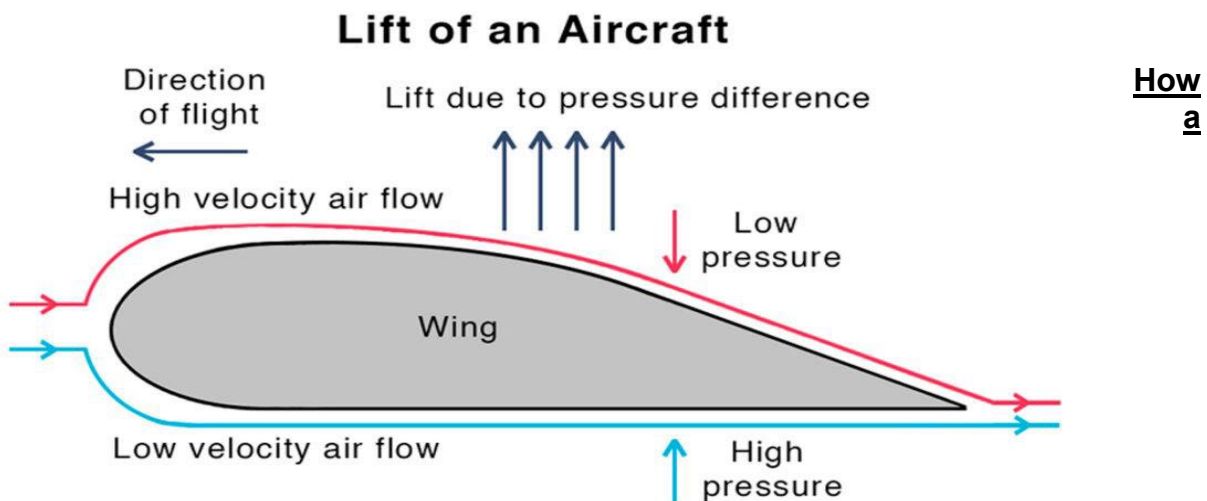

#### Quadcopter or Drone with Four Rotors Flies.

14. A quadcopter, or drone with four rotors, flies by controlling the speed and direction of its motors to generate lift and manoeuvre in the air. Here is how it works:-

(a) **Lift Generation.** Each of the four rotors (propellers) spins at high speed to generate upward force (lift). This is what keeps the quadcopter in the air. The rotors are arranged in two pairs, two spin clockwise (CW) and two spin counter-clockwise (anticlockwise) (CCW). The counteracting spins cancel out any rotational torque that would cause the drone to spin uncontrollably.

(b) **Pitch (Forward/Backward Movement).** To pitch the quadcopter forward or backward (i.e., move it in that direction), the speed of the front or rear rotors is adjusted. Increasing the speed of the rear rotors and decreasing the speed of the front rotors causes the drone to tilt forward, pushing it in that direction. Similarly, the opposite action moves it backward.

(c) **Roll (Side-to-Side Movement).** For roll (side-to-side movement), the left or right rotor speeds are adjusted. If the left rotors are spun faster and the right rotors slower, the quadcopter tilts to the right. The opposite applies for a roll to the left.



(d) **Yaw (Rotation or Turning)**. Yaw involves the rotation of the quadcopter around its vertical axis. This is controlled by adjusting the speeds of the clockwise and anticlockwise spinning rotors. For example, increasing the speed of the CW rotors and decreasing the speed of the CCW rotors will cause the quadcopter to rotate clockwise. This rotation allows the quadcopter to change its direction without needing a rudder like in traditional aeroplanes.

(e) **Altitude Control**. The quadcopter's altitude is controlled by the overall speed of all four rotors. When all rotors spin faster, they generate more lift, causing the quadcopter to ascend. Slowing the rotors down will reduce lift, making the quadcopter descend.

(f) **Hover**. Where fixed wing aircraft use thrust to create forward motion and then use wings to convert this forward motion into lift, but **in multi rotors, lift equals total thrust**. This only happens when the drone is level.

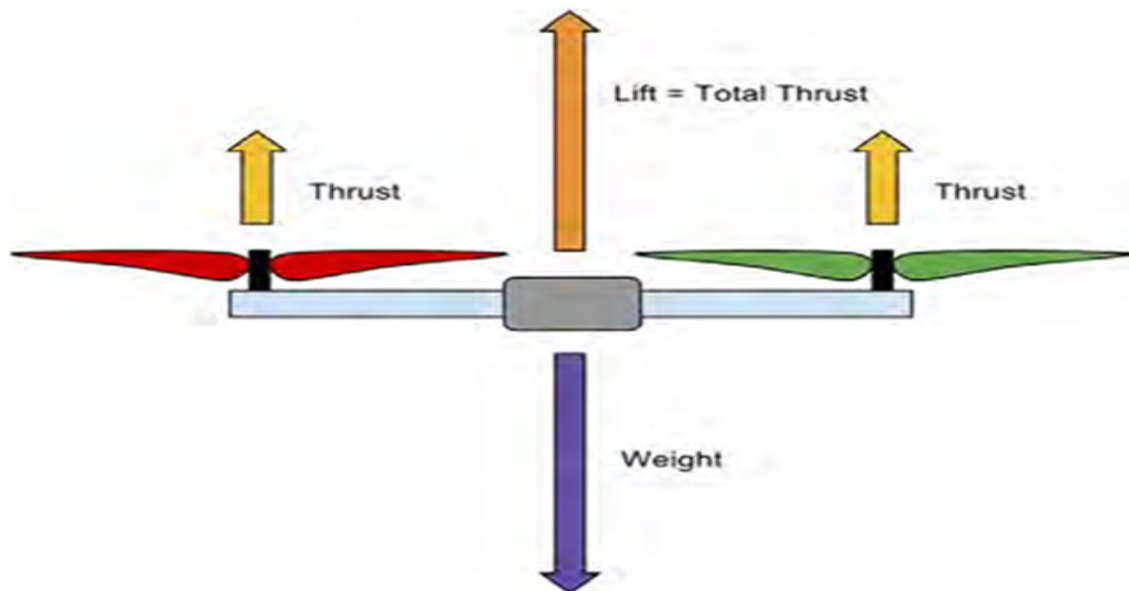

#### **PART IV : MANOEUVERS, PHASES AND CIRCUIT PATTERN**

15. **Basic Aircraft Manoeuvres**. In aviation, manoeuvres and turns are essential techniques pilots use to control their aircraft.

- (a) **Straight and Level Flight**. Maintaining a constant altitude and heading.
- (b) **Climbs**. Increasing altitude by increasing the angle of attack and/or thrust.
- (c) **Descents**. Decreasing altitude by reducing thrust and/or increasing the angle of attack.
- (d) **Turns**. Changing direction by banking the aircraft and adjusting the rudder.



16. **Phases of Flight.** The **phases of flight** describe the various stages an aircraft goes through from the moment it starts moving on the ground until it comes to a complete stop after landing. Understanding these phases is crucial for ensuring safety and efficiency in aviation.

- (a) **Takeoff.** When the aircraft accelerates along the runway and lifts off the ground, it is called 'takeoff'.
- (b) **Climb.** When the aircraft gains altitude after takeoff, it is called 'climb'.
- (c) **Cruise.** When the aircraft maintains a steady altitude and speed, it is called 'Cruise'.
- (d) **Descent.** When the aircraft loses altitude before landing, it is called a 'descent'.
- (e) **Landing.** When the aircraft slows down and touches down on the runway safely, it called a 'landing'.



17. Understanding these phases helps pilots, air traffic controllers, and ground crew to coordinate and ensure the safety and efficiency of flight operations. Each phase has specific procedures and protocols to maintain safety and compliance with aviation regulations. These well-defined stages not only ensure smooth operations but also enhance the overall safety.

18. **Circuit Pattern.** A circuit pattern is a standardized flight path used by pilots to practice basic flying skills and approach landing procedures. By understanding these fundamental manoeuvres, turns, and circuit patterns, pilots can safely and efficiently operate their aircraft. They typically involve the following stages -

- (a) **Take-off Leg.** The aircraft flies into the wind to maintain stability.
- (b) **Crosswind Leg.** The aircraft turns to fly perpendicular to the wind.



- (c) **Downwind Leg.** The aircraft flies perpendicular to runway and with the wind to gain speed.
- (d) **Base Leg.** The aircraft turns towards the runway.
- (e) **Final Approach.** The aircraft descends and aligns with the runway.

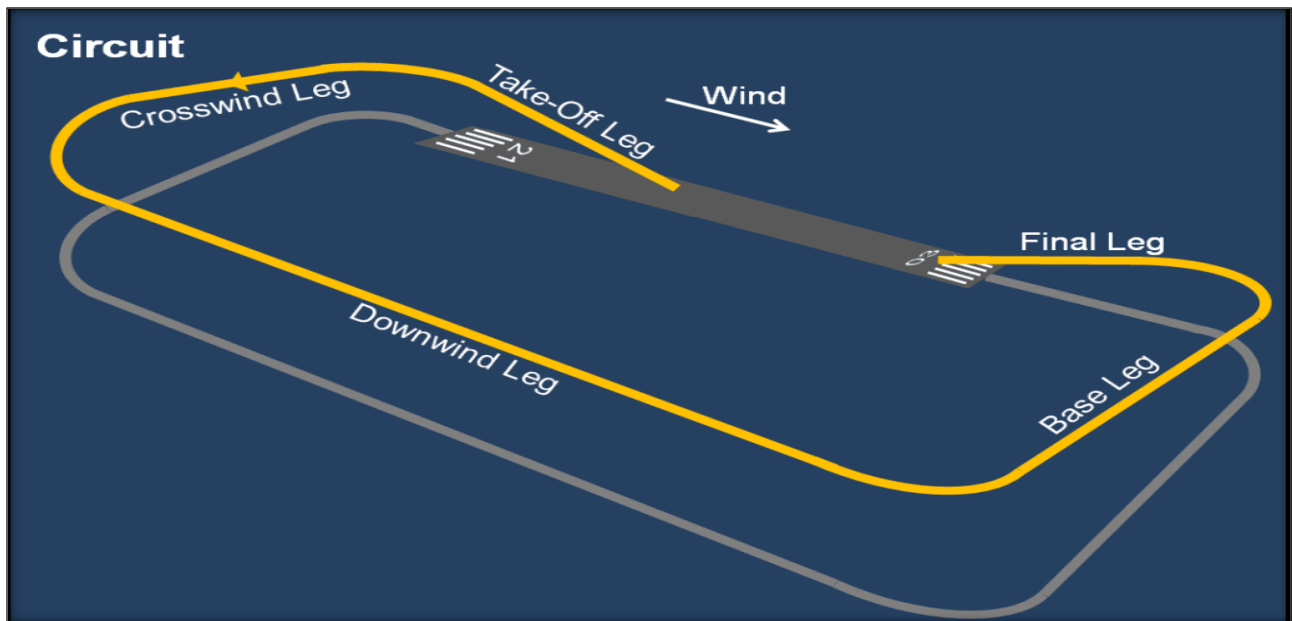

## CONCLUSION

19. Understanding the fundamental principles of flight is essential for appreciating the complex interplay of forces that allow fixed-wing and rotor drones to soar through the skies. The study of air in motion and its interaction with solid surfaces, particularly the aerofoil dictates the shape of drone wings. A balance in the **four forces acting on any drone or aircraft, namely**, lift, weight, thrust, and drag is necessary for a stable flight. The **control surfaces of** ailerons, elevators and rudders enable pilots to control the aircraft's pitch, roll, and yaw. By mastering these principles, pilots can operate drones safely and efficiently, ensuring the continued advancement of drone aviation technology and its contribution to global connectivity.

## SUMMARY

- A chord line is a line joining the centres of curvature of the leading and trailing edges of an aerofoil section.
- Angle of Attack is an angle between the chord line of an aerofoil and the relative airflow.
- Angle of Incidence is the angle between the chord line and the longitudinal axis of the aircraft.
- The four forces are lift, weight, drag, and thrust.



- There are three axes around which all aircraft move.
- The primary controls are the ailerons, elevator, and rudder.
- There are four fundamental basic flight manoeuvres upon which all flying tasks are based.
- Faster fluid flow leads to lower pressure.
- **Aeroplane wings** generate lift by creating pressure differences.
- The concept of drones may well date back to 1849.
- 1915-1920 saw a giant leap forward in drone technology.
- BVLOS (Beyond Visual Line of Sight): The drone operates autonomously or with remote control. BVLOS requires advanced technology and strict regulations.



## **ASSESSMENT EXERCISE**

### **Multiple Choice Questions**

- Q1. Which of the following is NOT one of the four forces of flight?
- (a) Lift (b) Weight  
(c) Friction (d) Thrust
- Q2. Which two forces are directly opposing in flight?
- (a) Lift and drag (b) Thrust and weight  
(c) Lift and weight (d) Drag and lift
- Q3. What is the primary function of ailerons on an aircraft?
- (a) To control yaw (b) To control pitch  
(c) To control roll (d) To control thrust
- Q4. What does the rudder control on an aircraft?
- (a) Pitch (b) Roll  
(c) Yaw (d) Lift
- Q5. Around which axis does an aircraft pitch?
- (a) Longitudinal (b) Vertical  
(c) Lateral (d) Diagonal
- Q6. Which axis controls the yaw of an aircraft?
- (a) Longitudinal (b) Vertical  
(c) Lateral (d) Diagonal
- Q7. Which of the following is required for heavier-than-air flight?
- (a) Drag must exceed thrust (b) Weight must exceed lift  
(c) Lift must balance weight (d) Thrust must balance drag
- Q8. Which aircraft phase involves the transition from moving on the ground to flying in the air?
- (a) Landing (b) Takeoff  
(c) Taxiing (d) Climbing



- Q9. Which aircraft type does NOT require a runway for takeoff?
- (a) Fixed-wing aircraft                      (b) Helicopters  
(c) Commercial jets                          (d) Airliners
- Q10. What is the last phase of flight where an aircraft returns to the ground?
- (a) Takeoff                                      (b) Climb  
(c) Descent                                      (d) Landing
- Q11. Which manoeuvre is NOT one of the four basic flight manoeuvres?
- (a) Turns                                        (b) Climbs  
(c) Spirals                                      (d) Descents
- Q12. What is the purpose of the elevator in an aircraft?
- (a) To control roll                            (b) To control pitch  
(c) To control yaw                            (d) To control lift
- Q13. What flight manoeuvre involves increasing the altitude of the aircraft?
- (a) Turn                                         (b) Climb  
(c) Descent                                      (d) Roll
- Q14. What is the key factor to manage during landing to ensure a safe descent?
- (a) Pitch control                              (b) Lift and weight balance  
(c) Thrust exceeding drag                    (d) Straight-and-level flight
- Q15. What is the primary focus of circuit flying?
- (a) Practicing aerobatics                    (b) Learning take-offs, turns, and landings  
(c) Flying in adverse weather              (d) Mastering high-speed flight

### **True or False**

- Q1. Lift and weight must be equal to maintain level flight.
- Q2. The rudder controls the roll of the aircraft.
- Q3. Thrust is the force that opposes drag.
- Q4. The elevator controls the yaw of an aircraft.
- Q5. An aircraft pitches around its longitudinal axis.
- Q6. Landing requires balancing lift and weight for a safe descent.
- Q7. Heavier-than-air flight requires drag to exceed thrust.



- Q8. The vertical axis of an aircraft is responsible for yaw movements.
- Q9. Ailerons are primarily used to control the pitch of the aircraft.
- Q10. Takeoff is the phase of flight where an aircraft transitions from ground movement to air travel.
- Q11. Helicopters and VTOL aircraft do not need a runway for takeoff.
- Q12. During straight-and-level flight, all forces (lift, weight, drag, and thrust) are balanced.
- Q13. Turns, climbs, descents, and rolls are the four fundamental flight manoeuvres.
- Q14. Circuit flying helps develop a pilot's ability to separate and manage air traffic.
- Q15. A climb is when an aircraft loses altitude.

### **Short Answer Questions**

- Q1. What is the primary function of an aerofoil?
- Q2. Define the chord line of an aerofoil section.
- Q3. What is the angle of attack in relation to an aerofoil?
- Q4. What is the angle of incidence in aviation?
- Q5. Name the four forces acting on an aircraft.
- Q6. How many axes do aircraft move around?
- Q7. What are the primary flight controls of an aircraft?
- Q8. Name the four fundamental basic flight manoeuvres.
- Q9. What happens to pressure when fluid flow increases?
- Q10. How do aeroplane wings generate lift?

### **Long Answer Questions**

- Q1. Discuss how the angle of attack affects the lift generated by an aerofoil.
- Q2. Describe the four fundamental forces acting on an aircraft and their interactions during flight. Explain the three axes of movement for aircraft and how they affect flight dynamics.
- Q3. Discuss the functions of the primary flight controls: ailerons, elevator, and rudder.
- Q4. Outline the four fundamental basic flight manoeuvres and their importance in aviation training.



## DRONES

### CHAPTER D III : DGCA RULES ON DRONES

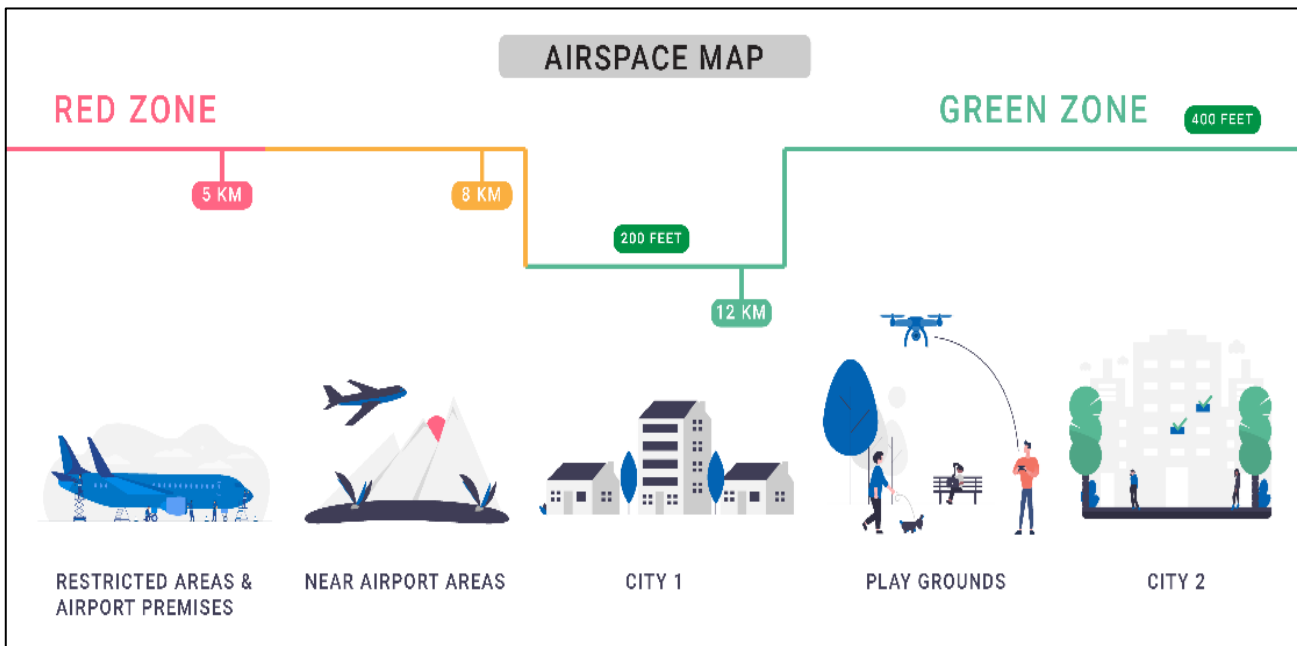

### TEACHING INSTRUCTIONS

<b>Periods</b>	:	Two (02)
<b>Type</b>	:	Lecture and Presentation
<b>Year</b>	:	2nd Year SD/SW
<b>Conducting Officer</b>	:	Officer/ Trained PI/ AMI/CGI
<b>Training Aids</b>	:	Class Room, Computer with OHP, Screen, Pointer Staff, Presentation, Script or Book Flagged or Lesson Plan in File, Board and Markers, and Models.

#### Time Plan

➤ Introduction	:	05 min
➤ Registration of UAS	:	10 min
➤ RPC, Extension & Validity	:	25 min
➤ RPTO	:	20 min
➤ Safety Guidelines by DGCA	:	15 min
➤ Q & A Session and Conclusion	:	05 min



## INTRODUCTION

1. The Directorate General of Civil Aviation (DGCA) is the national authority responsible for regulating the use of drones in India. To ensure safety and efficiency, the DGCA has set specific rules that govern how drones should be operated. These rules cover a range of aspects, such as registration, pilot training, flight permissions, and no-fly zones, all aimed at preventing accidents and ensuring drones are used responsibly.
2. The regulations also focus on ensuring that drones do not interfere with manned aircraft and that they operate within legal and ethical boundaries. For anyone wishing to operate a drone, following DGCA guidelines is crucial to ensure safe and legal flights.

### PREVIEW

The lecture will be conducted in the following parts:-

- Part I : Registration of UAS
- Part II : RPC, Extension & Validity
- Part III : RPTO
- Part IV : Safety Guidelines by DGCA

### LEARNING OBJECTIVES

- To understand DGCA rules before flying Drones.
- To learn about Remote Pilot Certification and training Organisation.
- Understanding to Safety guidelines by DGCA

## PART I : REGISTRATION OF UNMANNED AIRCRAFT SYSTEM

3. **General.** No person shall operate an unmanned aircraft system without first registering it on the digital sky platform and obtaining a unique identification number, unless exempted from the requirement of a unique identification number under these rules.
4. **Application and Procedure for Registration.** Any person who intends to register and obtain a unique identification number for his unmanned aircraft system shall make an application in Form D-2 on the Digital Sky platform along with the fee.
5. **Transfer of Unmanned Aircraft Systems.** A person may transfer an unmanned aircraft system to another person by way of sale, lease, gift, or any other mode after providing requisite details of the transferor, transferee, and unique identification number of the unmanned aircraft system in Form D-3 on the Digital Sky platform, along with the fee.
6. **De-Registration of Unmanned Aircraft Systems.** Where an unmanned aircraft system registered in a person's name is either permanently lost or permanently damaged, they shall, on arriving at a reasonable conclusion that it is so lost or damaged, apply for de-registration of such unmanned aircraft system by submitting an application in Form D-3 on the Digital Sky platform along with the fee.



## **PART II : RPL, EXCEPTION AND VALIDITY**

7. **General.** No individual other than a holder of a valid Remote Pilot License(RPL) enlisted on the Digital Sky platform shall operate an unmanned aircraft system.
8. **Classification.** A remote pilot licence shall specifically mention the category, sub-category and classification of the unmanned aircraft system or a combination of these, for which it is issued.
9. **Eligibility.** The following are the criteria under which an individual shall be eligible to obtain a remote pilot license:-
- (a) If they are not less than eighteen years of age and not more than sixty-five years of age.
  - (b) If an individual has successfully passed the class tenth examination or its equivalent from a recognised board.
  - (c) If the individual has successfully completed such training as may be specified by the Director General of Govt Aviation from any authorised remote pilot training organisation.
10. **Procedure for Obtaining a Remote Pilot Licence (RPL).**
- (a) Any individual who desires to obtain a remote pilot license for any category shall complete the training specified by the DGCA and pass the tests conducted by the authorised remote pilot training organisation.
  - (b) Within seven days of successfully completing the training and passing the required test under an authorised Remote Pilot Training Organisation (RPTO), an application for a remote pilot license in Form D-4 shall be submitted on the Digital Sky platform along with the applicable fee. The remote pilot certificate shall then be issued through the Digital Sky platform.
11. **Validity of license.** A remote pilot license shall be valid only if it is enlisted on the Digital Sky platform unless suspended or cancelled, and is remaining valid for a period of ten years.
12. **Exemption from Obtaining a License.** No remote pilot license shall be required for:-
- (a) Operating a Nano unmanned aircraft system.
  - (b) Operating a micro unmanned aircraft system for non-commercial purposes.



### **PART III : REMOTE PILOT TRAINING ORGANISATION (RPTO)**

13. **General.** No person other than an authorised remote pilot training organisation shall impart training to an individual seeking a remote pilot license.
14. **Eligibility.** No remote pilot training organisation shall be authorised to impart training unless it meets the eligibility criteria as may be specified by the Director General of Civil Aviation.
15. **Procedure for Obtaining Authorisation.** Any person who intends to obtain the authorisation to establish a remote pilot training organisation shall submit an application to the Director General of Civil Aviation in Form D-5 on the Digital Sky platform, along with the fees.
16. **Validity.** An authorisation to establish a remote pilot training organisation shall, unless suspended or cancelled, remain valid for a period of ten years.

### **PART IV : DIGITAL SKY PLATFORM**

17. Digital Sky Platform(DSP) means the online platform hosted by the Directorate General of Civil Aviation (DGCA) for various activities related to the management of unmanned aircraft system activities in India. Digital Sky is a web portal for registration, certification, authorisation, and flight planning of Unmanned Aircraft Systems (UAS) in India. It provides various services such as type certificate, unique identification number, transfer, remote pilot certificate, training organisation, and airspace map.

18. **Features of the Digital Sky Platform.**

- (a) **Drone Registration.** Drones must be registered on the platform before they can be operated legally.
- (b) **Operator Permit.** Operators need to obtain permits, ensuring they meet all regulatory requirements.
- (c) **Instant Online Clearances.** Every flight needs an online clearance, which can be obtained instantly through the platform.
- (d) **No Permission, No Take-off (NPNT).** The platform enforces this policy, which means drones won't take off without the required permission.
- (e) **Geo-fencing and Tracking.** The system includes features for geo-fencing and tracking to ensure safe operations.



## HOW DIGITAL SKY WORKS

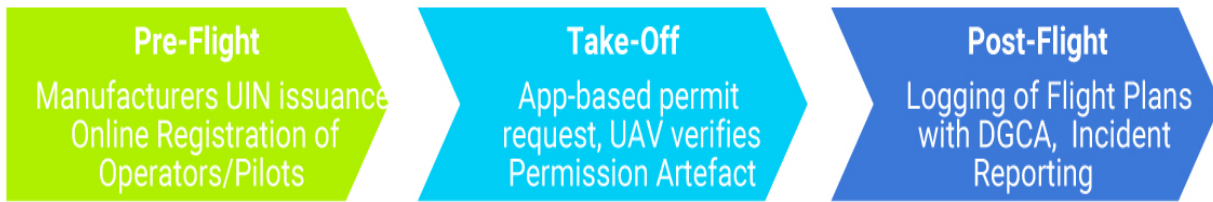

### MANUFACTURER PROCESS



Manufacturers send details of UAV, Operating Manual, Technical Specifications

Testing of drones by DGCA to see if secure implementation

Manufacturer Produces compliant UAVs with inbuilt UINs

### ONLINE PROCESS



Submit UIN + Flight Plan + Pilot(s) Details On App

Send to Digital Sky API. Backend engine, checks against Geofenceset up by security agencies

Receive Digitally Signed certificate, known as Permission Artefact

### FLIGHT LOGGING



Actual Flight Path is recorded as standard XML file and uploaded to Digital Sky

Verify if actual location & flying height within allowed bounds of Permission Artefact. Generate Incident Report if not

### PILOT/OPERATOR PROCESS



Pilots, Operators registers on DGCA

Pilot authentication

Permanent UAPL Number issued

### OFFLINE PROCESS



Drones request for Permission Artefact before take-off

Verify if current location & flying height within allowed bounds of Permission Artefact.

Only take-off if all conditions are met and Pilot Pin is entered

### INCIDENT SELF-REPORTING

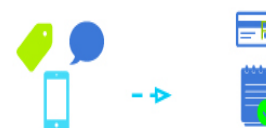

In case of crashes or property damage, Pilot has option to tag & self-report incident via App

Pilot e-Signs flight path & incident report / no incident certificate

## Airspace Zones (Green, Yellow, And Red)

19. The airspace map of India shows red, yellow, and green zones across the country, allowing civilian drone operators to check the demarcated no-fly zones or where they need to undergo certain formalities before permitted to fly one.

20. India has a well-defined airspace map for drone operations, which is available on the Digital Sky platform by the Directorate General of Civil Aviation. The airspace is divided into three zones:-



- (a) **Green Zone.** Green Zone is an airspace up to 400 feet that is not designated as a red or yellow zone. No permission is required for operating drones in these areas.
- (b) **Yellow Zone.** Airspace above 400 feet in a designated green zone, above 200 feet in areas located between 8-12 km from the perimeter of an operational airport, and above ground in areas located between 5-8 km from the perimeter of an operational airport is designated as 'Yellow Zone'. Permissions are required to operate in these zones.
- (c) **Red Zone.** A complete no-fly zone where drone operations are prohibited without special authorisation is called a 'Red Zone'.

21. These zones help ensure safe and regulated drone operations across the country. If you are planning to fly a drone, make sure to check the latest airspace map on the Digital Sky platform.

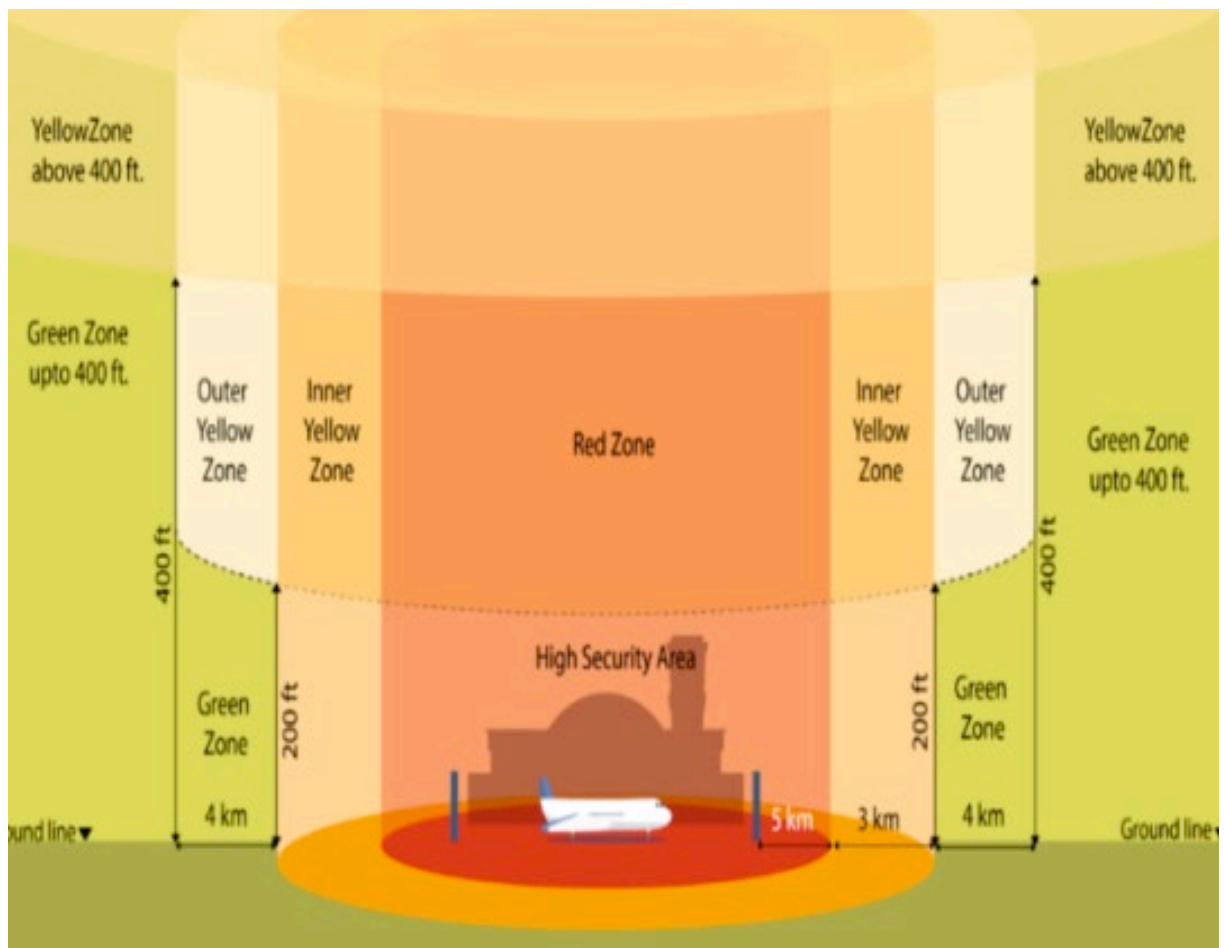

## **Insurance**

22. The provisions of the Motor Vehicles Act, 1988 (59 of 1988) and rules made thereunder shall apply to the third-party insurance of unmanned aircraft systems and compensation in case of damage to life or property caused by such an unmanned aircraft system, provided that a Nano unmanned aircraft system may operate without third-party insurance.



## CONCLUSION

23. The registration and operation of unmanned aircraft systems (UAS) in India are governed by a comprehensive regulatory framework implemented by the Directorate General of Civil Aviation (DGCA).

### KEY POINTS TO REMEMBER

- **Registration.** All UAS, except for Nano UAS, must be registered on the Digital Sky Platform to obtain a unique identification number.
- **Remote Pilot Certification.** Individuals operating UAS must possess a valid remote pilot license issued by the DGCA.
- **Airspace Zones.** India's airspace is divided into red, yellow, and green zones, with specific regulations governing drone operations in each zone.
- **Digital Sky Platform.** This online platform is crucial for registration, certification, flight planning, and other UAS-related activities.

24. By adhering to these regulations and utilising the Digital Sky platform, individuals can safely and legally operate UAS in India, contributing to the growth of this emerging technology.

## SUMMARY

- **Mandatory Registration.** All UAS must be registered on the Digital Sky Platform and obtain a Unique Identification Number (UIN), unless specifically exempted.
- **Application Process.** Registration involves submitting Form D-2 on the Digital Sky Platform.
- **Transfer and De-Registration.** Transfer requires submission of Form D-3, and de-registration is necessary for a lost or permanently damaged UAS.
- **License Requirement.** Operating a UAS requires a valid remote pilot license, specifying the category and classification of the UAS.
- **Exemptions.** Nano UAS and micro UAS used for non-commercial purposes do not require a license.
- **Green Zone.** Up to 400 feet, no permission required.
- **Yellow Zone.** Requires permissions, especially near airports.
- **Red Zone.** It's a complete No-fly zone and Drones cannot fly without special authorisation.
- **Requirement.** Third-party insurance as per the Motor Vehicles Act, 1988, is mandatory for UAS, except for nano UAS operating without third-party insurance.



## **ASSESSMENT EXERCISE**

### **Multiple Choice Questions**

- Q1. What is the primary platform for drone registration and management in India?
- (a) DGCA Portal (b) Civil Aviation Website  
(c) Digital Sky Platform (d) Drone Regulation Hub
- Q2. Which form is required to apply for a unique identification number for an unmanned aircraft system?
- (a) Form D-1 (b) Form D-2  
(c) Form D-3 (d) Form D-5
- Q3. What is required before transferring an unmanned aircraft system to another person?
- (a) Unique Identification Number (UIN) and Fee (b) Written Permission  
(c) Police Clearance (d) No formalities are needed.
- Q4. A remote pilot license in India is valid for how many years?
- (a) 5 years (b) 10 years  
(c) 15 years (d) Lifetime
- Q5. Which of the following is not required to hold a remote pilot license?
- (a) Operating a nano unmanned aircraft system  
(b) Operating a micro unmanned aircraft system for commercial purposes  
(c) Operating a micro unmanned aircraft system for non-commercial purposes  
(d) Operating a remote pilot organisation
- Q6. At what age is an individual eligible to obtain a remote pilot license?
- (a) 16 years (b) 18 years  
(c) 21 years (d) 25 years
- Q7. Which of the following does NOT apply to Nano unmanned aircraft systems?
- (a) Remote pilot license requirement (b) Third-party insurance requirement  
(c) Registration requirement (d) Both a and b



Q8. What is the maximum permissible altitude for drone operations in a green zone without permission?

- (a) 100 feet
- (b) 200 feet
- (c) 400 feet
- (d) 500 feet

Q9. Which of the following is true about red zones for drone operations?

- (a) They are areas where drones can fly without any restrictions.
- (b) No-fly zones unless special authorisation is granted.
- (c) Only commercial drones are restricted.
- (d) Drones can fly freely below 200 feet.

Q10. Which form is used to deregister a permanently lost or damaged drone?

- (a) Form D-2
- (b) Form D-3
- (c) Form D-5
- (d) Form D-7

Q11. Which feature ensures that drones won't take off without required permissions on the Digital Sky platform?

- (a) Auto-pilot Mode
- (b) No Permission, No Take-off(NPNT)
- (c) Geo-fencing
- (d) Flight Clearance

Q12. Which of the following is NOT a feature of the Digital Sky platform?

- (a) Drone Registration
- (b) Geo-fencing
- (c) Drone Insurance
- (d) Instant Online Clearances

Q13. To obtain a remote pilot license, what is the minimum educational qualification required?

- (a) Class 8
- (b) Class 10
- (c) Class 12
- (d) Graduate degree

Q14. Which airspace zone requires permission to operate above 400 feet?

- (a) Green Zone
- (b) Red Zone
- (c) Yellow Zone
- (d) White Zone

Q15. What is required to establish a Remote Pilot Training Organisation (RPTO)?

- (a) Form D-2
- (b) Form D-3
- (c) Form D-4
- (d) Form D-5



Q16. Which of the following organisations authorises remote pilot training organisations in India?

- (a) Ministry of Civil Aviation
- (b) Directorate General of Civil Aviation (DGC(A))
- (c) Indian Air Force
- (d) National Aviation Authority

Q17. What is the purpose of geo-fencing in drone operations?

- (a) Prevent drones from entering restricted zones.
- (b) Enable drones to fly faster.
- (c) Improve drone camera quality
- (d) Extend battery life

Q18. What is the required third-party insurance for drones based on?

- (a) Drone size
- (b) Motor Vehicles Act, 1988
- (c) Aviation law
- (d) Airspace zone

Q19. Which of the following drones are exempt from third-party insurance requirements?

- (a) Nano unmanned aircraft systems
- (b) Commercial drones
- (c) Micro drones used for delivery
- (d) All drones require third-party Insurance.

Q20. The validity period of authorisation to establish a remote pilot training organisation is:-

- (a) 5 years
- (b) 7 years
- (c) 10 years
- (d) Lifetime

### **True or False**

- Q1. Drones in the green zone can fly up to 400 feet without permission.
- Q2. The Digital Sky platform is only used for drone registration and not for flight planning.
- Q3. A remote pilot license is valid for a period of five years.
- Q4. Operating a Nano unmanned aircraft system requires a remote pilot license.
- Q5. No special authorisation is required to fly a drone in a red zone.



- Q6. Geo-fencing helps prevent drones from entering restricted areas.
- Q7. A drone transfer must be reported to the Digital Sky platform using Form D-3.
- Q8. A person can establish a remote pilot training organisation without DGCA authorisation.
- Q9. Micro unmanned aircraft systems used for non-commercial purposes require a remote pilot license.
- Q10. Insurance for drones follows the Motor Vehicles Act, 1988.
- Q11. In the yellow zone, permission is required to fly above 200 feet near an airport.
- Q12. NPNT (No Permission, No Take-off) ensures drones won't take off without necessary permissions.
- Q13. A drone license is required for all unmanned aircraft systems, including nano drones.
- Q14. An individual must be at least 21 years old to apply for a remote pilot license.
- Q15. De-registration of lost or damaged drones requires Form D-5 submission.

### **Short Answer Questions**

- Q1. What must all UAS be registered on?
- Q2. What form is used to apply for UAS registration?
- Q3. How can UAS be transferred?
- Q4. What form is used for de-registration of a UAS?
- Q5. What is required to operate a UAS?
- Q5. What does the remote pilot license specify?
- Q6. What are the eligibility criteria for obtaining a remote pilot license?
- Q7. What form is used to apply for a remote pilot license?
- Q8. How long is a remote pilot license valid?
- Q9. Who can provide training for remote pilot licenses?
- Q10. What form is used to apply for establishing an RPTO?
- Q11. What platform manages UAS activities in India?
- Q12. What are the three zones for drone operation in India?
- Q13. What insurance requirements apply to UAS?



### **Long Answer Questions**

- Q1. Describe the general requirements and process for registering an unmanned aircraft system (UAS) on the Digital Sky Platform.
- Q2. Explain the procedure and requirements for transferring and de-registering a UAS.
- Q3. Discuss the remote pilot certification process, including eligibility, application, validity, and exemptions.
- Q4. Analyse the role and importance of the Remote Pilot Training Organisation (RPTO) in the certification process.
- Q5. Provide an overview of the Digital Sky Platform, including its functions in drone registration, operator permits, online clearances, and geo-fencing.
- Q6. Describe the three zones for drone operation in India and the specific permissions required for each.
- Q7. Explain the insurance requirements for UAS in India and any exemptions that apply.



## DRONES

### CHAPTER D IV : APPLICATION OF DRONES



#### TEACHING INSTRUCTIONS

<b>Period</b>	:	One (01)
<b>Type</b>	:	Lecture and Presentation
<b>Year</b>	:	3rd Year SD/SW
<b>Conducting Officer</b>	:	Officer of the Unit
<b>Training Aids</b>	:	Classroom, Computer with OHP, Screen, Pointer Staff, Presentation, Script or Book Flagged or Lesson Plan in File, Board and Markers, and Models.

#### Time Plan

➤ Introduction	:	05 min
➤ Application of Drones in Various Fields	:	10 min
➤ Search & Rescue and Disaster Response	:	10 min
➤ Career Opportunities in Drone Industry	:	08 min
➤ Q & A Session and Conclusion	:	07 min



## INTRODUCTION

1. Drone is a very versatile equipment because they can be flown remotely. It has an exceptional quality of taking aerial photos and videos, giving a splendid view from the sky. Plus, they are handy for delivering packages, especially to those in hard-to-reach places. These are just a few examples of the many uses of drones that make them immensely valuable.

2. Farmers now use drones to check their crops from a bird's eye view. These are the changing technology. And it is not just for them-drones are also used in search and rescue mission to find people in difficult spots. This new use of drones is changing farming and emergency response incredibly.

### PREVIEW

The lecture will be conducted in the following parts:-

- Part I : Application of drones in various fields.
- Part II : Search & Rescue and Disaster Response.
- Part III : Career Opportunities in Drone Industry

### LEARNING OBJECTIVES

- To know the application & usage of drones.
- To know how the drones are helpful in search & rescue.

## PART I : APPLICATION OF DRONES

3. Drones can reach hard-to-access or dangerous areas, inspect wind turbines, monitor construction sites, and survey agricultural fields. They often have cameras, GPS, and sensors to capture high-quality images and data. This makes them useful for precision tasks in fields like real estate, media, public safety, and many more things.

4. Use of drones is on the rise, with industries finding innovative ways to utilise this technology. Other than military, some of the most common uses of drones are given in succeeding paragraphs.

### Agriculture

5. **Crop Monitoring and Health Assessment.** Due to the efficacy of drone applications, farmers can now easily check their crops' health and look out for pests and diseases. These gadgets have special cameras that give detailed information about plant health. This technology helps farmers quickly spot problem areas and act fast.

6. **Precision Farming.** Drones with sensors and cameras can take detailed, high-resolution pictures of crops. These photos help farmers monitor crop health, spot pests, and catch diseases early. By reviewing this data, farmers can decide where to spray pesticides, use fertilisers, or water their crops. This boosts productivity, reduces waste, and lessens environmental impact.



## **Environmental Monitoring and Conservation**

7. **Wildlife Tracking and Poaching Prevention.** Drones are making a difference in monitoring wildlife and stop poaching. They can cover huge areas and gather real-time data without bothering the animals, which helps conservationists monitor wildlife's movements and behaviour. Drones with thermal cameras can spot poachers, especially at night, allowing authorities to act quickly against illegal activities. This technology is a revolutionary innovation for protecting endangered species because it makes the surveillance extra efficient and less intrusive.

8. **Forest Management.** When it comes to forest management, drones are transformative innovations. They can fly over vast areas to check on tree health, watch for deforestation, and spot illegal logging. With Light Detection and Ranging (LiDAR) technology, drones create detailed 3D maps of forests, showing the canopy structure and forest biomass. This information is key for sustainable forest management, making planning and conservation much easier. Drones can also speed up reforestation by spreading seeds over large, hard-to-reach areas. It is a faster, more efficient way to plant trees.

## **Infrastructure Inspection and Construction**

9. **Building and Structural Inspections.** Drones are changing the perspective of inspecting the buildings and structures. They are making it faster, safer, and cheaper. Instead of using scaffolding, ladders, or even helicopters, drones can easily reach those hard-to-get spots and capture clear images and videos. This helps engineers and inspectors find issues like cracks or rust without being there in person. Plus, it keeps the inspection thorough and safe, reducing risks and keeping things smooth.

10. **Construction Site Monitoring.** Keeping track of construction progress is important for meeting deadlines and ensuring quality work. Drones can help a lot with this. They provide a bird's-eye view of the entire site, letting project managers see a real time image. By doing regular aerial surveys, they can capture photos and videos that show how the project is going and highlight any issues. This technology also helps teams communicate better since everyone gets clear visual data. Besides, it helps manage inventory by checking materials on-site, ensuring resources are used smartly, and timelines are met.



## **Energy Sector**

11. **Wind Turbine Inspection.** Wind turbines need regular check-ups to ensure they are working safely. Drone use cases for these inspections are remarkable. Drones can fly close to the turbines, taking high-resolution photos and videos of the blades and other parts. This helps engineers quickly spot any damage or wear and tear without having to climb up those tall structures. The whole process becomes faster, safer, and more accurate. Repairs can be done quickly, thereby reducing downtime and keeping the turbines running smoothly for continuous energy.

12. **Solar Panel Inspections.** It is important to maintain solar panels properly to keep them working well. Drones with thermal cameras can help by quickly scanning large solar farms and finding issues like hotspots from damage or debris. Catching these problems early, prevents energy loss and keeps everything running efficiently. This technology saves time and reduces the need for manual checks, allowing technicians to fix issues faster. Overall, it helps solar farms produce clean energy reliably.

## **Media and Entertainment**

13. **Event Coverage.** Drones are transforming how we cover events in media and entertainment. They give us unique aerial views that used to be expensive or impossible. At concerts, sports, or festivals, they capture wide shots of the crowd and stage, making viewers feel more involved. They can quickly move around to cover different parts of an event, providing real-time footage for live broadcasts. This flexibility helps media companies create more engaging content.

14. **Cinematography.** In filmmaking, drones have become a partner for cinematographers. They let you capture stunning aerial shots without needing cranes or helicopters, which cuts costs and sparks creativity. You can fly them through narrow spaces, hover at exact angles, and get smooth tracking shots, all of which boost visual storytelling. This means even small teams can now achieve amazing scenes that were tough with traditional setups. Overall, drones have made aerial cinematography more accessible and have added a tonne of flexibility and creativity to the industry.



### **Real Estate and Property Management**

15. **Property Showcases**. Drones have changed real estate. They give an incredible aerial view, showing buyers the whole property and its surroundings. This helps buyers see the neighbourhood, yard, and other details that regular photos might miss. These shots make listings more appealing and help properties sell faster. Agents can use them to show features like pools, gardens, and nearby amenities, giving a better overall view of the property.

16. **Land Survey**. Accurate land surveying is key in real estate. Drones make this process a lot easier by quickly capturing detailed data. They can map large areas faster than traditional methods, helping developers make quicker decisions and save time and money. They handle tough terrain well, so no part of the land gets missed. Using this technology gives precise and reliable data, which is essential for planning and development.

### **Drones in the Military**

17. Drones were created mainly for military purposes. Their use in all other areas that we have discussed above is but secondary. Countries at war have been using drones for a substantial period of time, dating back as early as World War I. Use of drones made a lot of sense in wars given the fact that the lives of pilots don't have to be risked.

18. Today, drones are available in many forms and sizes and are used by numerous countries around the world. They have played a role in predicting conflicts and also in helping countries fight wars with fewer casualties.





## Commercial Uses of Drones

19. Commercial use of drones is on the rise, with industries finding innovative ways to utilise this technology. Some of the most common commercial uses of drones include:-

- (a) **Aerial Photography and Videography**. Drones have revolutionised film and TV production.
- (b) **Construction and Infrastructure Inspection**. In construction, drones make surveying land, monitoring progress, and inspecting structures easy and fast.
- (c) **Agriculture**. Drones are revolutionising agriculture by improving how we manage crops.
- (d) **Energy Sector**. Drones are changing the energy sector by making maintenance and inspections easier and cheaper.
- (e) **Environmental Monitoring and Conservation**. Drones are an asset for environmental monitoring and conservation.
- (f) **Delivery and Logistics**. Companies like Amazon are testing drone delivery services and integrating these flying robots into delivery and logistics.
- (g) **Real Estate and Property Management**. Drones can provide detailed aerial footage of properties, giving potential buyers or renters a better understanding of the space.

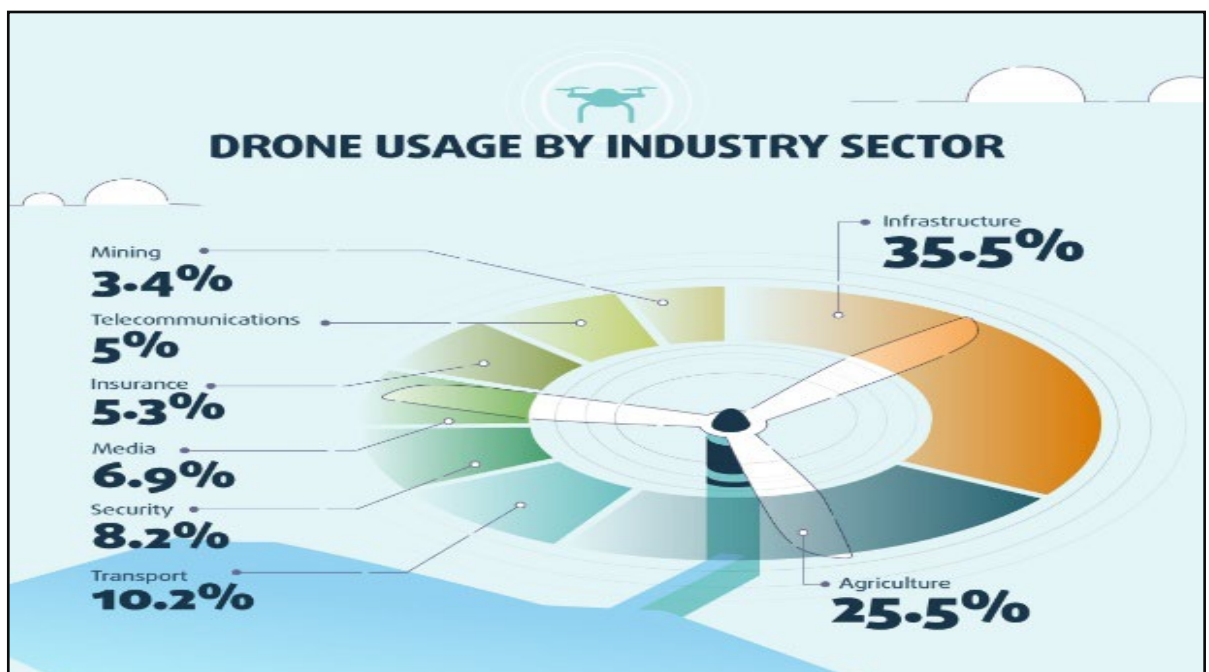

**Mining and Surveying.** The mining industry has been revolutionised by drones, offering a safer and more efficient method to survey and map mining sites.



## **Key Benefits of Using Drones**

20. **Cost-effective.** Drones are much more affordable than traditional methods like helicopters or cranes, making them accessible to smaller production teams and industries.
21. **Efficiency.** Drones can cover large areas quickly and provide high-resolution images and data in a fraction of the time as compared to traditional methods. This saves time, resources, and labour costs.
22. **Versatile.** Drones can be equipped with different cameras and tools depending on the specific needs of each industry. This versatility makes them useful in various applications such as aerial photography, mapping, surveying, delivery, etc.
23. **Safe.** Drones eliminate the need for workers to access dangerous or hard-to-reach areas, making operations safer for everyone involved. They also are equipped with advanced collision avoidance technology to prevent accidents.
24. **Eco-friendly.** Drones reduce the need for traditional methods that emit harmful pollutants, making them a more environmentally friendly option for various industries.

## **PART II : DISASTER MANAGEMENT AND RESPONSE**

### **Search and Rescue Operations**

25. Drones are super advanced now, with high-resolution cameras and thermal imaging. They can quickly scan big areas to find survivors, which is great when traditional methods are too slow or risky. For example, after an earthquake, they can help rescuers find trapped people by detecting body heat. Plus, they can access hard-to-reach or dangerous places, letting rescue teams provide help fast without risking more lives.

### **Damage Assessment**

26. After a disaster, it is really important to quickly check the damage to plan recovery. Drones can fly around and take detailed pictures, giving authorities a fast overview. This helps understand the impact and prioritise efforts. Using drones is quicker and more accurate than doing inspections on foot, leading to faster decisions and quicker resource deployment where needed most. Drones offer great support for efficient disaster response.

### **Public Safety and Law Enforcement**

27. **Crime Scene Analysis.** Drones are changing how we analyse crime scenes by providing detailed aerial views. They take high-resolution images from various angles, helping us spot details we might miss on the ground. This helps preserve evidence and document it efficiently, assisting law enforcement in building stronger cases and solving crimes faster. Besides, use of Drones mean we disturb the crime scene less, keeping its integrity intact.

28. **Crowd Monitoring.** Handling large crowds at events can be tough for police, but drones make it easier. They fly overhead, watch crowd movements in real-time, and give a view that ground officers can't get. This helps spot issues like overcrowding or disturbances quickly, so responses are faster. Drones improve public safety and help



events run smoothly. They are cost-effective and reduce the need for lots of police, making the atmosphere more comfortable for everyone.

29. **Public Safety.** Public safety agencies like police, fire departments, and search and rescue teams find drones very useful. With thermal cameras, they can locate missing persons or detect fire hotspots. This helps emergency personnel respond quickly and safely. In disasters, drones give real-time aerial views to assess damage, find survivors, and map affected areas. They can also deliver medical supplies or rescue gear to hard-to-reach places. This is a critical drone use that enhances public safety operations.

### **Unmanned Combat Aerial Vehicle (UCAV)**

30. An unmanned combat aerial vehicle (UCAV), also known as a combat drone, fighter drone, or battlefield UAV, is an unmanned aerial vehicle (UAV) that is used for intelligence, surveillance, target acquisition, and reconnaissance. It can also carry carries aircraft ordnance such as missiles, anti-tank guided missiles (ATGMs), and/or bombs for the strike.

31. **Weapon Systems Used in Drones.** Drones, especially those used in military operations, can be equipped with a variety of weapon systems. Some common types are as follows:-

(a) **Missiles.** Drones can carry air-to-surface missiles, such as the Hellfire missile, which is designed for precision strikes against ground targets.

(b) **Bombs.** Various types of bombs, including guided bombs and cluster bombs, can be deployed from drones.

(c) **Anti-Tank Missiles.** Drones can be equipped with Anti-Tank Guided Missiles (ATGM) to target armoured vehicles.

(d) **Autocannons and Machine Guns.** Some drones are armed with autocannons and machine guns for close-range engagements.

(e) **Laser Guided Weapons.** These weapons use laser targeting to hit specific targets with pinpoint accuracy.

(f) **Incendiary Devices.** Drones can carry incendiary devices designed to start fires or destroy specific targets.

32. These weapon systems enable drones to carry out a range of missions from precision strikes to close air support.

### **Anti-Drone Systems**

33. Anti-Drone Systems, also known as Counter-Unmanned Aerial Systems(C-UAS), are designed to detect, track, and neutralise unauthorised malicious drones. Some common anti-drone systems are:-

(a) **RF Jamming.** RF refers to Radio Frequency. Devices like Drone Gun Tactical and Drone Defender V2 emit radio frequency signals to disrupt the communication links between the drone and its operator, forcing the drone to land or return to its home point.



- (b) **High Energy Laser Weapon System (HELWS)**. Systems like Raytheon's High Energy Laser Weapon System use laser beams to disable or destroy drones by targeting their sensitive components.
- (c) **Interceptor Drones**. Autonomous drones equipped with nets and other capture mechanisms that can physically engage and disable rogue drones in mid-air.
- (d) **GPS Spoofing**. Systems that manipulate GPS signals to mislead the drones' navigation system causing it to lose control.
- (e) **Projectiles**. Some systems use projectiles such as nets or missiles to physically capture or destroy drones.

34. These technologies are crucial for maintaining security and safety in various environments, from airports to critical infrastructure.

### **PART III : CAREER OPPORTUNITIES IN DRONE INDUSTRY**



35. The drone industry is rapidly expanding, opening up a wide range of exciting career opportunities across various sectors. Here are some of the key areas where drone technology is making a significant impact and creating job opportunities.

#### 36. **Drone Pilot**.

- (a) **Role**. Operate drones for photography, videography, surveying, mapping, inspections, deliveries, and more.
- (b) **Industries**. Real estate, construction, agriculture, film and media, public safety, and logistics.



37. **Drone Engineer.**

- (a) **Role.** Design, develop, and maintain drones and their components.
- (b) **Industries.** Aerospace, robotics, and drone manufacturing companies.

38. **Drone Data Analyst.**

- (a) **Role.** Analyse and interpret data collected by drones, such as aerial imagery and LiDAR data.
- (b) **Industries.** Agriculture, urban planning, environmental conservation, and insurance.

39. **Drone Software Developer.**

- (a) **Role.** Develop software for drone control, automation, and data processing.
- (b) **Industries.** Drone manufacturing companies, software development firms, and research institutions.

40. **Drone Instructor.**

- (a) **Role.** Train individuals on drone piloting, maintenance, and regulations.
- (b) **Industries.** Aviation schools, drone training academies, and corporate training programs.

41. **Drone Consultant.**

- (a) **Role.** Provide expert advice on drone technology, regulations, and business applications.
- (b) **Industries.** Various industries seeking to adopt drone technology.

42. **Drone Technician.**

- (a) **Role.** Perform maintenance, repairs, and troubleshooting on drones.
- (b) **Industries.** Drone service centres, rental companies, and drone manufacturers.

43. **Drone Traffic Manager.**

- (a) **Role.** Manage and coordinate drone traffic in urban and rural areas.
- (b) **Industries.** Aviation authorities and drone service providers.

44. **Drone Delivery Specialist.**

- (a) **Role.** Deliver goods and packages using drones.



(b) **Industries**. E-commerce, logistics, and healthcare.

45. **Drone Filmmaker/Photographer**.

(a) **Role**. Capture stunning aerial footage and images using drones.

(b) **Industries**. Film and television production, advertising, and real estate.

46. **Additional Career Opportunities**.

(a) **Drone Law Enforcement**. Assisting in law enforcement operations, search and rescue missions, and border patrol.

(b) **Drone Agriculture**. Monitoring crops, spraying pesticides, and delivering seeds.

(c) **Drone Inspection**. Inspecting infrastructure, power lines, and oil pipelines.

(d) **Drone Surveying and Mapping**. Creating detailed maps and 3D models of land and buildings.

47. To pursue a career in the drone industry, consider obtaining a drone pilot license, relevant certifications, and practical experience. Stay updated on the latest drone technology and industry trends to enhance your career prospects.

## **CONCLUSION**

48. Drones have emerged as a versatile tool with applications across various industries and sectors. From agriculture and construction to media and entertainment, drones are revolutionising the way we work and live.

49. **Key Benefits of Drone Technology:-**

(a) **Efficiency**. Drones can cover vast areas quickly and efficiently, saving time and resources.

(b) **Safety**. Drones can be used to inspect dangerous or inaccessible areas, reducing the risk to human life.

(c) **Data Collection**. Drones can collect high-resolution data, such as aerial photography and thermal imaging, to inform decision-making.

(d) **Precision**. Drones can perform tasks with precision, such as spraying on crops or delivering packages.



## HIGHER-ORDER THINKING SKILLS (HOTS)

- **Innovative Solutions.** Consider yourself in charge of creating a drone-based solution for managing traffic. How would you design the system to maximise traffic flow and reduce congestion? What factors would you consider, and why?
- **Ethical Implications.** Discuss the ethical considerations of using drones for public surveillance. How can privacy concerns be balanced with the benefits of enhanced security and crime prevention?
- **Environmental Impact.** Analyse the potential environmental impact of large-scale drone delivery services. What measures could be implemented to mitigate any negative effects, and how would these measures align with sustainable practices?
- **Interdisciplinary Integration.** How can drones be integrated into existing emergency response systems to improve efficiency and effectiveness? Propose a comprehensive plan that includes technological, logistical, and regulatory aspects.
- **Technological Advancements.** Evaluate the current limitations of drone technology in commercial applications, such as delivery services and agriculture. What technological advancements would you prioritise to overcome these limitations, and why?
- **Societal Impact.** Assess the societal implications of widespread drone usage in rural and remote areas. How can drones be leveraged to address challenges such as healthcare access, education, and infrastructure development?
- **Regulatory Frameworks.** Propose a regulatory framework for the use of drones in airspace shared with manned aircraft. How would you ensure safety and efficiency while promoting innovation and growth in the drone industry?
- **Global Applications.** Explore the potential applications of drones in developing countries. How can drones contribute to economic development, infrastructure improvement, and disaster management in these regions?
- **Future Prospects.** Envision the future of drone technology over the next decade. What new applications do you foresee emerging, and how will these advancements transform industries and daily life?

## SUMMARY

- **Agriculture.** Farmers use drones for crop monitoring, spraying pesticides, and analysing the field conditions. It is all about improving efficiency and yields.
- **Delivery Services.** Companies like Amazon are experimenting with drones for fast and efficient package delivery. Imagine getting your order in minutes.



- **Environmental Monitoring.** Drones help monitor wildlife, track deforestation, and survey areas affected by natural disasters. They provide crucial data without disturbing the ecosystems.
- **Entertainment.** In filmmaking, drones enable breath taking aerial shots that were once only possible with helicopters. They are also used in sports broadcasting and creating light shows.
- **Military.** Drones are used for reconnaissance, surveillance, and targeted strikes. They have transformed modern warfare but at the same time also raised ethical and legal questions.
- **Healthcare.** In remote areas, drones can deliver medical supplies, vaccines, and even blood. They offer a lifeline where traditional transport cannot reach.
- **Infrastructure Inspection.** Drones are used to inspect bridges, power lines, and pipelines. They can access hard-to-reach places and provide detailed images, ensuring timely maintenance and safety.
- **Personal Use.** Many people use drones for photography, racing, and also as a hobby. It is a fun way to explore and capture the world from new angles.



## **ASSESSMENT EXERCISE**

### **Multiple Choice Questions**

- Q1. Which industry uses drones to monitor crop health and boost yields?
- (a) Healthcare (b) Agriculture  
(c) Entertainment (d) Military
- Q2. Which company is known for experimenting with drone delivery services?
- (a) Google (b) Microsoft  
(c) Amazon (d) Apple
- Q3. In environmental monitoring, what is one key use of drones?
- (a) Delivering packages (b) Filming movies  
(c) Tracking wildlife and deforestation (d) Racing
- Q4. What kind of drones does the military typically use for reconnaissance and surveillance?
- (a) Delivery drones (b) Racing drones  
(c) Surveillance drones (d) Filmmaking drones
- Q5. Which industry uses drones for inspecting bridges, power lines, and pipelines?
- (a) Agriculture (b) Healthcare  
(c) Infrastructure inspection (d) Retail
- Q6. Drones are used in filmmaking primarily for what purpose?
- (a) Delivering scripts (b) Providing aerial shots  
(c) Monitoring audience reactions (d) Transporting equipment
- Q7. What kind of drones are used for entertainment purposes, like light shows and racing?
- (a) Delivery drones (b) Agricultural drones  
(c) Hobby drones (d) Military drones
- Q8. In the healthcare industry, how are drones being utilised?
- (a) Delivering medical supplies to remote areas  
(b) Performing surgeries  
(c) Monitoring patient health  
(d) Administering vaccines directly



Q9. Which application involves drones performing tasks such as spraying pesticides and mapping fields?

- (a) Retail
- (b) Agriculture
- (c) Military
- (d) Entertainment

Q10. How are drones contributing to disaster response efforts?

- (a) Delivering food
- (b) Surveying damaged areas and aiding in search and rescue operations
- (c) Recording news footage
- (d) Providing internet access

Q11. Which type of drones are used to capture stunning aerial footage for movies?

- (a) Delivery drones
- (b) Filmmaking drones
- (c) Military drones
- (d) Agricultural drones

Q12. In logistics, what is a primary use of drones?

- (a) Transporting employees
- (b) Delivering packages quickly and efficiently
- (c) Monitoring warehouses
- (d) Managing inventory

Q13. Which sector uses drones to provide inspection of infrastructure like power lines and towers?

- (a) Agriculture
- (b) Entertainment
- (c) Infrastructure inspection
- (d) Military

Q14. What is a common use of drones in the environmental sector?

- (a) Planting trees
- (b) Monitoring climate change effects
- (c) Building habitats
- (d) Introducing new species

Q15. In what context are drones used to provide realtime surveillance and intelligence?

- (a) Agriculture
- (b) Healthcare
- (c) Military operations
- (d) Entertainment



### **Fill in the Blanks**

- Q1. Drones are used in \_\_\_\_\_ to monitor crop health and increase yields.
- Q2. Companies like \_\_\_\_\_ are experimenting with drone delivery services.
- Q3. In environmental monitoring, drones are used to track \_\_\_\_\_ and deforestation.
- Q4. The \_\_\_\_\_ industry uses drones for providing stunning aerial shots movies.
- Q5. Drones used for surveying damaged areas and aiding in \_\_\_\_\_ operations are crucial in disaster response.
- Q6. In the healthcare industry, drones deliver \_\_\_\_\_ supplies to remote areas.
- Q7. For infrastructure inspection, drones provide detailed images of \_\_\_\_\_, power lines and pipelines.
- Q8. Drones used for personal \_\_\_\_\_ include photography and racing drones.
- Q9. In logistics, drones are used to deliver \_\_\_\_\_ quickly and efficiently.
- Q10. The \_\_\_\_\_ sector uses drones for realtime surveillance and intelligence.

### **Short Answer Questions**

- Q1. How are drones used in agriculture?
- Q2. Which company is experimenting with drones for fast and efficient package delivery?
- Q3. What environmental applications do drones have?
- Q4. How are drones utilised in filmmaking?
- Q5. Name two military uses of drones.
- Q6. What healthcare services can drones provide in remote areas?
- Q7. How do drones assist in infrastructure inspection?
- Q8. What are some personal uses of drones?



### **Long Answer Questions**

- Q1. Discuss the various ways drones are used in agriculture to improve efficiency and yields.
- Q2. Explain how companies like Amazon are using drones for delivery services and the potential benefits.
- Q3. Describe the role of drones in environmental monitoring, including their advantages.
- Q4. Analyse how drones have revolutionised the entertainment industry, particularly in filmmaking and sports broadcasting.
- Q5. Evaluate the impact of drones on modern warfare, considering both their benefits and the ethical/legal questions they raise.
- Q6. How do drones contribute to healthcare delivery in remote areas, and what are the potential impacts?
- Q7. Outline the advantages of using drones for infrastructure inspection and maintenance.
- Q8. Explore the various personal uses of drones and how they have changed the way people interact with technology for hobbies and photography.



## DRONES

### CHAPTER D V : DRONE OPERATIONS



#### TEACHING INSTRUCTIONS

<b>Periods</b>	:	Two (02)
<b>Type</b>	:	Lecture and Presentation
<b>Year</b>	:	3rd Year SD/SW
<b>Conducting Officer</b>	:	Officer/Trained PI/ AMI/ CGI
<b><u>Training Aids</u></b>	:	Classroom, Computer with OHP, Screen, Pointer Staff, Presentation, Script or Book Flagged or Lesson Plan in File, Board and Markers, and Models.

#### **Time Plan**

➤ Introduction	:	05 min
➤ Pre-Flight Checks	:	35 min
➤ Start Up & Controls	:	20 min
➤ Emergencies	:	12 min
➤ Q & A Session and Conclusion	:	08 min



## INTRODUCTION

1. Drones, also known as unmanned aerial vehicles (UAVs), have revolutionized various industries with their versatility and precision. From aerial photography and surveying to military operations and package delivery, drones are being utilized in a multitude of applications. Understanding the operations of drones is crucial to harnessing their potential and ensuring safe and efficient use. This chapter will delve into the basics of drone operations, covering aspects such as pre-flight checks and preparations, controls, manoeuvre and emergency procedures.

### PREVIEW

The lecture will be conducted in the following parts:-

- Part I : Pre-Flight Checks
- Part II : Start Up & Controls
- Part III : Emergencies

### LEARNING OBJECTIVES

- To know the pre-flight checks
- To learn Starting Up, Controls, and how drone is manoeuvred through the air
- To know and understand the emergencies relating to drones

## PART I : PRE-FLIGHT CHECKS

2. Pre-flight activities are the duty of the Remote Pilot in Command (RPIC) before the start of the flight operation. Activities include inspection of the aircraft, assessment of the operating location, briefing crew members involved in the operation, and equipment checkouts.

### Drone Pre-Flight Checklist

#### 3. Weather and Site Safety Check.

- (a) Chance of precipitation less than 10%
- (b) Wind speed under 15 knots (less than 20 mph or 32 km per hour)
- (c) Cloud base at least 500 feet
- (d) Visibility at least 5 km
- (e) If flying at dawn/dusk, double-check civil twilight hours.
- (f) Establish take-off, landing, and emergency hover zones.
- (g) Potential for electromagnetic interference?
- (h) Look for towers, wires, buildings, trees, or other obstructions.



- (j) Look for pedestrians and/or animals and set up a safety perimeter if needed.
- (k) Discuss the flight mission with other crew members if present.

4. **Airspace Research.**

- (a) Conduct Airspace Classification Review.
- (b) Check for NOTAMs (Notices to Airmen) and TFRs (Temporary Flight Restrictions).
- (c) Secure Airspace Authorisation (if required).
- (d) If airspace authorisation is required, make sure you have approval.

5. **Batteries, Updates, and Connectivity.**

- (a) Make sure drone batteries and remote-control batteries are fully charged.
- (b) Pack extra batteries as needed.
- (c) Make sure your drone and remote control have the latest firmware update installed.
- (d) Check your SD card(s) to make sure you have enough memory for the mission (if relevant).
- (e) Make sure you have a USB cable for your mobile phone or tablet.
- (f) Make sure you will have connectivity in the field.

6. **Visual Aircraft & System Inspection.**

- (a) The registration number is displayed properly and is legible.
- (b) Look for abnormalities-aircraft frame, propellers, motors, undercarriage.
- (c) Look for abnormalities-gimbal, camera, transmitter, payloads, etc.
- (d) Gimbal clamp and lens caps are removed.
- (e) Clean lens with a micro-fibre cloth.
- (f) Attach propellers, battery/fuel source, and insert SD card/lens filters.

7. **Powering Up.**

- (a) Turn on the remote control and open up the DJI Go 4 application.
- (b) Turn on aircraft
- (c) Verify established connection between transmitter and aircraft



- (d) Position antennas on the transmitter towards the sky.
- (e) Verify the display panel/FPV screen is functioning properly.
- (f) Calibrate Inertial Measurement Unit (IMU) as needed.
- (g) Calibrate the compass before every flight.
- (h) Verify battery/fuel levels on both transmitter and aircraft.
- (j) Verify that the UAS has acquired GPS location from at least six satellites.

#### 8. **Taking Off.**

- (a) Take off to eye-level altitude for about 10-15 seconds.
- (b) Look for any imbalances or irregularities.
- (c) Listen for abnormal sounds.
- (d) Pitch, roll, and yaw to test control response and sensitivity
- (e) Check for electromagnetic interference or other software warnings.
- (f) Do one final check to secure the safety of the flight operations area.
- (g) Proceed with flight mission.

### **PART II : START UP AND CONTROLS**

#### 9. The four main drone controls are achieved by:-

- (a) **Roll**. Done by pushing the right stick to the left or right. Literally rolls the drone, which manoeuvres the drone left or right.
- (b) **Pitch**. Done by pushing the right stick forwards or backward. Tilts the drone, which manoeuvres the drone forwards or backward.
- (c) **Yaw**. Done by pushing the left stick to the left or to the right. Rotates the drone left or right. Points the front of the copter in different directions and helps with changing directions while flying.
- (d) **Throttle**. To increase, push the left stick forwards. To decrease, pull the left stick backward. This adjusts the altitude, or height, of the drone.



### Basic In Flight : Controls

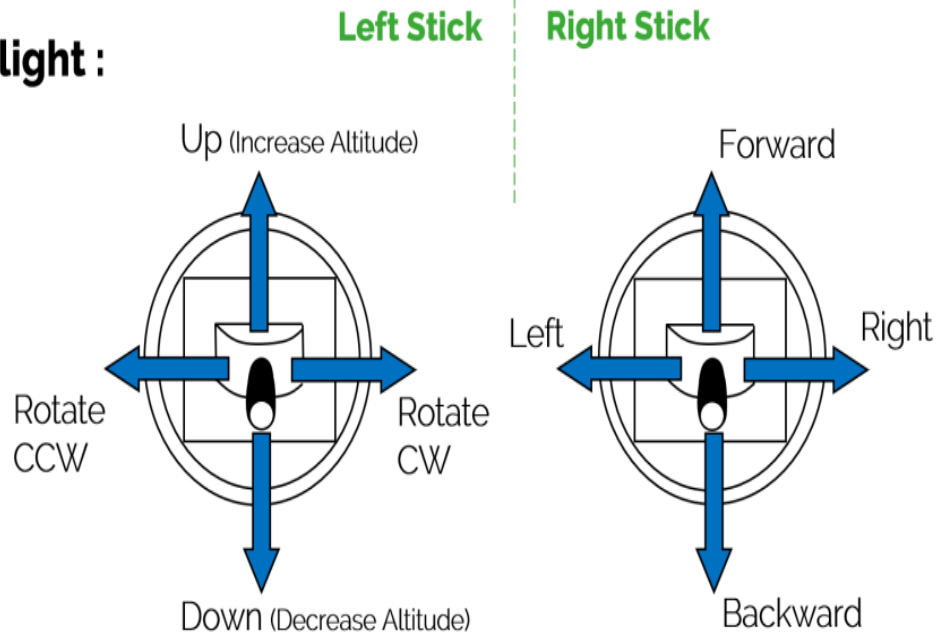

### How to Fly a Drone: Controls of Quadcopter

<p><b>Throttle</b></p> <p>Move down      Move up</p>		<p><b>Pitch</b></p> <p>Move forward      Move backward</p>	
<p><b>Roll</b></p> <p>Bend left      Bend Right</p>		<p><b>Yaw</b></p> <p>Rotate left      Rotate right</p>	
<p>○ Normal speed      ○ High Speed</p>			

## PART III : EMERGENCY PROCEDURES

10. Ensuring the safety of RPAS operations requires an understanding of associated risks or emergencies and their respective effects. The table below highlights potential RPAS-related emergency operations, its plausible effects, and appropriate contingency/ failsafe measures we have put in place to safeguard the same.



SER NO	EMERGENCY/ RISK/POTENTIAL HAZARD	POSSIBLE EFFECTS	CONTINGENCY PLAN/ FAILSAFE MEASURE
(a)	<b>Aircraft Fly-away/ Geofence non-conformance</b>	<ul style="list-style-type: none"> <li>• Mid-air collision with another manned or unmanned aerial aircraft.</li> <li>• Crash into buildings/obstacles.</li> <li>• Crash debris injuring people on the ground.</li> </ul>	Geo-fencing is always enabled and doesn't allow the pilot to fly outside the defined corridor.
(b)	<b>Battery Power Loss or Failure</b>	<ul style="list-style-type: none"> <li>• Uncontrolled descent or landing could cause serious injury to many persons on the ground and possible fatalities.</li> <li>• Chances of mid-air fire leading to damage of ground assets.</li> <li>• Crash landing.</li> </ul>	Battery failsafe cautions the pilot of a low battery warning and immediately initiates a return to home (RH) and lands the aircraft autonomously at a predefined location.
(c)	<b>Loss of Communication/ Control link</b>	<ul style="list-style-type: none"> <li>• RPAS crash into one or more buildings.</li> <li>• Obstacles resulting in widespread secondary injury to humans from UAS debris and/or building damage.</li> <li>• Uncontrolled descent.</li> </ul>	Communication failure will also trigger the smart RH, where the aircraft returns at a safe altitude.
(d)	<b>Unsuccessful Landing/ Flight Termination</b>	<ul style="list-style-type: none"> <li>• Vehicle break-up or totalling.</li> <li>• Post-crash fire that injures ground crew/threatens wildlife and environment.</li> <li>• RPAS collides with buildings/bridges/other obstacles, causing debris that injures or causes fatalities on the ground.</li> </ul>	Smart Return home is always active, thereby preventing aircraft from landing outside defined areas.
(e)	<b>RPAS loss of Control</b>	<ul style="list-style-type: none"> <li>• Undesired flight trajectory could cause mid-air collision with other RPAS or manned aircraft.</li> <li>• Uncontrolled descent or landing could cause serious injury</li> </ul>	Stabilisation and position holding based on GPS and INS reduces any uncontrolled action risk.



SER NO	EMERGENCY/ RISK/POTENTIAL HAZARD	POSSIBLE EFFECTS	CONTINGENCY PLAN/ FAILSAFE MEASURE
		to many persons on the ground and possible fatalities.	

### CONCLUSION

11. Pre-flight operations are crucial for ensuring the safety and success of drone flights. By following a comprehensive checklist and adhering to safety guidelines, pilots can mitigate risks and conduct safe and responsible operations.

12. **Key pre-flight considerations include:-**

- (a) **Aircraft Inspection**. Thoroughly inspect the drone for any damage or anomalies.
- (b) **Airspace Assessment**. Verify airspace regulations, identify potential hazards, and obtain necessary authorisations.
- (c) **Battery and System Check**. Ensure batteries are fully charged and the drone's systems are functioning correctly.
- (d) **Pilot Proficiency**. Ensure the pilot is adequately trained and familiar with the drone's controls and emergency procedures.
- (e) **Weather Conditions**. Assess weather conditions and avoid flying in adverse weather.

13. By prioritising safety and following established procedures, drone pilots can maximise the benefits of this technology while minimising potential risks.

- **Battery Check**. Ensure the drone's battery is fully charged and in good condition.
- **Propeller Inspection**. Check for any damage or wear on the propellers.
- **Motors**. Verify that all motors are functioning correctly.
- **GPS Signal**. Ensure the drone has a strong GPS signal.
- **Compass Calibration**. Calibrate the drone's compass to ensure accurate navigation.
- **Camera Settings**. Check the camera settings and functionality if your drone has one.



- **Firmware Updates.** Make sure the drone's firmware is up to date.
- **Weather Conditions.** Assess the weather conditions to ensure they are suitable for flying.
- **Flight Controls.** Test the flight controls to ensure they are responsive.
- **Pre-flight Test Flight.** Perform a short test flight to check everything is working properly.
- **Loss of Signal.** Activate RTH before flight.
- **Battery Emergencies.** Initiate RTH or safe landing.
- **GPS Signal Loss.** Use position hold mode for manual control.

### HIGHER-ORDER THINKING SKILLS (HOTS)

- **Risk Assessment.** Analyse the importance of pre-flight checks in drone operations. How can neglecting these checks lead to potential risks, and what preventive measures can be put in place to mitigate these risks?
- **System Integration.** Evaluate the integration of automated systems in pre-flight checks. How can AI and machine learning enhance the accuracy and efficiency of these checks, and what challenges might arise from this integration?
- **Scenario Planning.** Imagine a situation where a drone experiences a critical system failure mid-flight. Develop a comprehensive emergency protocol that includes immediate actions, risk management, and post-incident analysis.
- **Ethical Implications.** Discuss the ethical considerations involved in drone operations, particularly in urban areas. How can pre-flight checks and operational protocols be designed to ensure public safety and privacy?
- **Technological Advancements.** Investigate the role of emerging technologies such as Internet of Things (IOT) and 5G in improving drone pre-flight checks and operations. What benefits do these technologies offer, and what potential drawbacks should be considered?
- **Environmental Impact.** Assess the environmental impact of drone operations. How can pre-flight checks be modified to ensure drones operate efficiently and minimise their ecological footprint?



## **ASSESSMENT EXERCISE**

### **Multiple Choice Questions**

- Q1. What should you check for any signs of damage or swelling before a flight?
- (a) Motors (b) Propellers  
(c) Battery (d) GPS
- Q2. Which component should be inspected for cracks, bends, or chips?
- (a) Camera (b) Propellers  
(c) Chassis (d) Controller
- Q3. What should be calibrated in an open area to ensure accurate navigation?
- (a) Camera (b) Battery  
(c) Compass (d) Motors
- Q4. Which update should you check for and install before a flight?
- (a) Weather report (b) Firmware  
(c) Software (d) Flight logs
- Q5. What should you check for a strong signal before taking off?
- (a) Wi-Fi (b) Bluetooth  
(c) GPS (d) Radio
- Q6. What would you perform to check the drone systems are functioning correctly before the actual flight?
- (a) Full flight (b) Ground test  
(c) Short test flight (d) Visual inspection
- Q7. Which weather conditions should you avoid flying in?
- (a) Mild breeze (b) Clear skies  
(c) High winds and rain (d) Cloudy
- Q8. What should you test for responsiveness to ensure full control of the drone?
- (a) Motors (b) Flight controls  
(c) Propellers (d) GPS



- Q9. What must be in good condition to prevent mid-air power loss?
- (a) Motors (b) Chassis  
(c) Battery (d) Propellers
- Q10. Which component needs to have its cleanliness checked to guarantee clear footage?
- (a) GPS (b) Compass  
(c) Camera lens (d) Firmware
- Q11. What should be spun by hand to check for smooth operation?
- (a) Propellers (b) Motors  
(c) Compass (d) Battery
- Q12. Which condition requires calibration to avoid flight issues?
- (a) Camera settings (b) Battery levels  
(c) Compass calibration (d) Propeller alignment
- Q13. Which component's settings should be checked if the drone has one?
- (a) Propellers (b) Camera  
(c) Battery (d) Motors
- Q14. What kind of low-altitude test should be conducted before a flight?
- (a) Emergency landing test (b) Battery drain test  
(c) Preflight test flight (d) Weather resistance test
- Q15. What should be assessed to ensure they are suitable for flying?
- (a) Wind speed (b) Weather conditions  
(c) Propeller condition (d) GPS signal
- Q16. Which control is responsible for changing the altitude of a drone?
- (a) Roll (b) Pitch  
(c) Yaw (d) Throttle
- Q17. Which control adjusts the drone's forward and backward movement?
- (a) Roll (b) Pitch  
(c) Yaw (d) Throttle



- Q18. What does the yaw control effect on a drone?
- (a) Altitude (b) Horizontal movement  
(c) Rotation around the vertical axis (d) Speed
- Q19. Which control would you use to make the drone move left or right?
- (a) Roll (b) Pitch  
(c) Yaw (d) Throttle
- Q20. Combining which two controls allows the drone to fly in a diagonal direction?
- (a) Throttle and yaw (b) Pitch and roll  
(c) Roll and throttle (d) Pitch and yaw
- Q21. What is the first step you should take if your drone loses signal?
- (a) Increase altitude (b) Turn off the controller  
(c) Initiate Return to Home (RTH) (d) Fly in manual mode
- Q22. What should you do if your drone starts drifting uncontrollably?
- (a) Increase throttle  
(b) Perform a compass calibration  
(c) Reduce throttle and land immediately  
(d) Switch to sport mode
- Q23. If you notice a low battery warning in mid-flight, what action should you take?
- (a) Fly further away to complete your mission.  
(b) Ignore the warning.  
(c) Return the drone to the home point as soon as possible.  
(d) Land it in the nearest safe area.
- Q24. In the event of a motor failure during flight, what is the best course of action?
- (a) Try to regain control (b) Perform an emergency landing  
(c) Increase throttle (d) Ignore the failure and continue flying.
- Q25. What should you do if your drone encounters strong unexpected winds?
- (a) Increase the speed to combat the wind.  
(b) Fly lower and closer to the ground.  
(c) Hover in place until the wind subsides.  
(d) Ascend to a higher altitude.



### **Short Answer Questions**

- Q1. What should be ensured about the drone's battery before flight?
- Q2. Why is propeller inspection important?
- Q3. What needs to be verified regarding the drone's motors?
- Q4. What should be checked to ensure accurate navigation?
- Q5. How do you ensure the drone's camera is functioning properly?
- Q6. Why are firmware updates important for drones?
- Q7. What should be assessed before flying a drone?
- Q8. Why is a pre-flight test flight important?
- Q9. What should be activated before flight in case of a loss of signal?
- Q10. What should be done during battery emergencies?

### **Long Answer Questions**

- Q1. Describe the steps involved in preparing a drone for flight, focusing on battery check, propeller inspection, and motor verification.
- Q2. Explain the importance of GPS signal strength and compass calibration for drone navigation.
- Q3. Discuss the procedures and checks needed to ensure the camera settings and firmware updates are up to date on a drone.
- Q4. Analyse the factors to consider regarding weather conditions and flight controls before operating a drone.
- Q5. Outline the emergency procedures to follow in the event of a loss of signal, battery emergencies, and GPS signal loss during drone flight.



**ANSWER KEY :**  
**MULTIPLE CHOICE**  
**QUESTIONS (MCQ)**



**ANSWER KEY TO MCQ : FD**

**Answer Key to MCQ : FD (Chapter - I)**

Q1. (a)	Q2. (c)	Q3. (a)	Q4. (d)
Q5. (d)	Q6. (a)	Q7. (a)	Q8. (a)
Q9. (c)	Q10. (a)	Q11. (a)	Q12. (b)

**Answer Key to MCQ : FD (Chapter - II)**

Q1. (b)	Q2. (b)	Q3. (b)	Q4. (b)
Q5. (c)	Q6. (d)	Q7. (c)	Q8. (c)
Q9. (b)	Q10. (a)	Q11. (a)	Q12. (a)
Q13. (c)			

**Answer Key to MCQ : FD (Chapter - III)**

Q1. (a)	Q2. (a)	Q3. (b)	Q4. (b)
Q5. (b)	Q6. (c)	Q7. (a)	Q8. (a)
Q9. (d)	Q10. (c)	Q11. (b)	Q12. (d)
Q13. (d)			

**Answer Key to MCQ : FD (Chapter - IV)**

Q1. (c)	Q2. (c)	Q3. (d)	Q4. (b)
---------	---------	---------	---------

**Answer Key to MCQ : FD (Chapter - V)**

Q1. (a)	Q2. (c)	Q3. (b)	Q4. (a)
Q5. (b)	Q6. (d)	Q7. (a)	Q8. (a)
Q9. (a)	Q10. (a)	Q11. (a)	Q12. (a)
Q13. (a)	Q14. (a)	Q15. (a)	Q16. (d)
Q17. (a)	Q18. (d)		

**Answer Key to MCQ : FD (Chapter - VI)**

Q1. (a)	Q2. (a)	Q3. (b)	Q4. (b)
Q5. (b)	Q6. (c)	Q7. (b)	Q8. (b)
Q9. (a)	Q10. (a)		

**Answer Key to MCQ : FD (Chapter - VII)**

- |         |          |         |         |
|---------|----------|---------|---------|
| Q1. (a) | Q2. (a)  | Q3. (a) | Q4. (a) |
| Q5. (b) | Q6. (a)  | Q7. (b) | Q8. (b) |
| Q9. (a) | Q10. (b) |         |         |

**Answer Key to MCQ : FD (Chapter - VIII)**

- |         |         |
|---------|---------|
| Q1. (c) | Q2. (b) |
|---------|---------|

**Answer Key to MCQ : FD (Chapter - IX)**

- |         |          |         |         |
|---------|----------|---------|---------|
| Q1. (a) | Q2. (a)  | Q3. (b) | Q4. (b) |
| Q5. (b) | Q6. (c)  | Q7. (b) | Q8. (b) |
| Q9. (a) | Q10. (a) |         |         |

**Answer Key to MCQ : FD (Chapter - X)**

- |         |         |         |         |
|---------|---------|---------|---------|
| Q1. (d) | Q2. (c) | Q3. (a) | Q4. (d) |
| Q5. (a) | Q6. (d) | Q7. (c) | Q8. (c) |
| Q9. (a) |         |         |         |

**ANSWER KEY TO MCQ : AD****Answer Key to MCQs : AD (Chapter- I)**

- |          |          |          |          |
|----------|----------|----------|----------|
| Q1. (b)  | Q2. (d)  | Q3. (d)  | Q4. (b)  |
| Q5. (d)  | Q6. (a)  | Q7. (a)  | Q8. (b)  |
| Q9. (b)  | Q10. (a) | Q11. (d) | Q12. (b) |
| Q13. (b) | Q14. (b) | Q15. (b) |          |

**Answer Key to MCQs : AD (Chapter- II)**

- |         |          |         |         |
|---------|----------|---------|---------|
| Q1. (a) | Q2. (b)  | Q3. (c) | Q4. (b) |
| Q5. (d) | Q6. (b)  | Q7. (a) | Q8. (b) |
| Q9. (a) | Q10. (c) |         |         |



**Answer Key to MCQs : AD (Chapter- III)**

Q1. (a)	Q2. (a)	Q3. (c)	Q4. (d)
Q5. (c)	Q6. (a)	Q7. (a)	Q8. (b)
Q9. (a)			

**Answer Key to MCQs : AD (Chapter- IV)**

Q1. (c)	Q2. (a)	Q3. (a)	Q4. (d)
Q5. (a)	Q6. (a)	Q7. (b)	Q8. (a)
Q9. (a)	Q10. (b)	Q11. (a)	

**Answer Key to MCQs : AD (Chapter- V)**

Q1. (c)	Q2. (a)	Q3. (b)	Q4. (b)
Q5. (d)	Q6. (a)	Q7. (c)	

**Answer Key to MCQs : AD (Chapter- VI)**

Q1. (a)	Q2. (b)	Q3. (c)	Q4. (a)
Q5. (a)	Q6. (c)	Q7. (c)	Q8. (a)
Q9. (a)	Q10. (b)	Q11. (b)	Q12. (a)
Q13. (b)	Q14. (a)	Q15. (c)	

**Answer Key to MCQs : AD (Chapter- VII)**

Q1. (b)	Q2. (a)	Q3. (c)	Q4. (d)
Q5. (c)	Q6. (a)	Q7. (c)	Q8. (d)

**ANSWER KEY TO MCQ : WT**

**Answer Key to MCQs : WT (Chapter- I)**

Q1. (a)	Q2. (b)	Q3. (b)	Q4. (c)
Q5. (a)	Q6. (c)	Q7. (a)	Q8. (a)
Q9. (b)	Q10. (a)	Q11. (a)	Q12. (b)
Q13. (c)	Q14. (c)		

**Answer Key to MCQs : WT (Chapter- II)**

Q1. (d)	Q2. (c)	Q3. (a)	Q4. (b)
Q5. (a)	Q6. (a)	Q7. (b)	Q8. (b)
Q9. (b)	Q10. (d)	Q11. (b)	Q 12. (c)
Q13. (b)	Q14. (a)	Q15. (c)	

**Answer Key to MCQs : WT (Chapter- III)**

Q1. (c)	Q2. (b)	Q3. (c)	Q4. (a)
Q5. (d)	Q6. (d)	Q7. (b)	Q8. (d)
Q9. (b)	Q10. (a)	Q11. (c)	Q12. (a)
Q13. (c)	Q14. (c)	Q15. (a)	

**Answer Key to MCQs : WT (Chapter- IV)**

Q1. (b)	Q2. (a)	Q3. (c)	Q4. (a)
Q5. (d)	Q6. (a)	Q7. (d)	Q 8. (c)
Q9. (d)	Q10. (b)	Q11. (b)	Q12. (c)
Q13. (a)	Q14. (a)	Q 15. (b)	

**Answer Key to MCQs : WT (Chapter- V)**

Q1. (b)	Q2. (b)	Q3. (a)	Q4. (d)
Q5. (b)	Q6. (b)	Q7. (b)	Q8. (b)
Q9. (c)	Q10. (c)	Q11. (c)	Q12. (d)
Q13. (a)	Q14. (a)	Q15. (a)	

**ANSWER KEY TO MCQ : OT****Answer Key to MCQs : OT (Chapter-I)**

Q1. (c)	Q2. (b)	Q3. (d)	Q4. (d)
Q5. (c)	Q6. (d)	Q7. (b)	Q8. (c)
Q9. (b)	Q10. (c)	Q11. (a)	Q12. (b)
Q13. (c)	Q14. (b)	Q15. (c)	Q16. (a)
Q17. (c)	Q18. (c)	Q19. (c)	Q20. (b)



## ANSWER KEY TO MCQ : DRONE

### Answer Key to MCQs : D (Chapter-I)

Q1. (c)	Q2. (b)	Q3. (c)	Q4. (b)
Q5. (c)	Q6. (b)	Q7. (b)	Q7. (b)
Q8. (c)	Q9. (c)	Q10. (a)	Q11. (b)
Q12. (c)	Q13. (c)	Q14. (b)	Q15. (c)

### Fill in the Blanks

Q1. Digital Sky Platform	Q2. Aircraft	Q3. Exempt
Q4. Digital Sky Platform	Q5. India	

### Answer Key to MCQs : D (Chapter-II)

Q1. (c)	Q2. (c)	Q3. (c)	Q4. (c)
Q5. (c)	Q5. (b)	Q7. (c)	Q8. (b)
Q9. (b)	Q10. (d)	Q11. (c)	Q12. (b)
Q13. (b)	Q14. (b)	Q15. (b)	

### True/ False

Q1. True	Q2. False	Q3. True	Q4. False
Q5. False	Q6. True	Q7. False	Q8. True
Q9. False	Q10. True	Q11. True	Q12. True
Q13. False	Q14. True	Q15. False	

### Answer Key to MCQs : D (Chapter-III)

Q1. (c)	Q2. (b)	Q3. (a)	Q4. (b)
Q5. (a)	Q6. (b)	Q7. (d)	Q8. (c)
Q9. (b)	Q10. (b)	Q11. (b)	Q12. (c)
Q13. (b)	Q14. (c)	Q15. (d)	Q16. (b)
Q17. (a)	Q18. (b)	Q19. (a)	Q20. (c)

**True/ False**

- |            |            |            |           |
|------------|------------|------------|-----------|
| Q1. True   | Q2. False  | Q3. False  | Q4. False |
| Q5. False  | Q6. True   | Q7. True   | Q8. False |
| Q9. False  | Q10. True  | Q11. True  | Q12. True |
| Q13. False | Q14. False | Q15. False |           |

**Answer Key to MCQs : D (Chapter-IV)**

- |          |          |          |          |
|----------|----------|----------|----------|
| Q1. (b)  | Q2. (c)  | Q3. (c)  | Q4. (c)  |
| Q5. (c)  | Q6. (b)  | Q7. (c)  | Q8. (a)  |
| Q9. (b)  | Q10. (b) | Q11. (b) | Q12. (c) |
| Q13. (b) | Q14. (c) | Q15. (c) |          |

**Fill in the Blanks**

- |                 |                       |               |
|-----------------|-----------------------|---------------|
| Q1. Agriculture | Q2. Amazon            | Q3. Wildlife  |
| Q4. Filmmaking  | Q5. Search and Rescue | Q6. Medical   |
| Q7. Bridges     | Q8. Hobbies           | Q10. Military |

**Answer Key to MCQs : D (Chapter-V)**

- |          |          |          |           |
|----------|----------|----------|-----------|
| Q1. (c)  | Q2. (b)  | Q3. (c)  | Q4. (b)   |
| Q5. (c)  | Q6. (c)  | Q7. (c)  | Q8. (b)   |
| Q9. (c)  | Q10. (c) | Q11. (b) | Q12. (c)  |
| Q13. (b) | Q14. (c) | Q15. (b) | Q16. (d)  |
| Q17. (b) | Q18. (c) | Q19. (a) | Q20. (b)  |
| Q21. (c) | Q22. (c) | Q23. (c) | Q 24. (b) |
| Q25. (b) |          |          |           |



UNITY & DISCIPLINE

Directorate General of NCC  
Ministry of Defence, RK Puram New Delhi- 110066